

PROJECT: _____

MODEL: _____

ITEM #: _____ QUANTITY: _____

APPROVAL: _____ DATE: _____

2/2021

Item #177BMR2CD

Barrel Merchandiser Cooler 2.25 Cu. Ft.

Features:

- Digital thermostat sets internal temperature between 32 and 50 °F.
- Operates in an ambient temperature up to 90 °F.
- 2 poly-coated metal baskets hold up to 66 lb.
- LED strip lights up interior of freezer
- Polyurethane foam insulation for temperature retention.
- Includes 4 casters
- Eco-friendly R290 hydrocarbon refrigerant.
- 115V; 1/5 hp



Cabinet Construction:

Sturdy design features white galvanized sheet exterior and aluminum interior.

Foamed-in-place CFC- and HCFC-free polyurethane insulation enhances the structural integrity of the cabinet and promotes energy efficiency.

Refrigeration System:

Environmentally safe R290 refrigerant.

Shelving:

Features 2 poly-coated metal baskets that can handle up to 66 lb.

Model Features:

Easy to maneuver with 4 casters.

See-through, flip-top lid for clear product visibility.

Wrapped design helps attract attention and boost impulse sales.

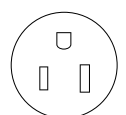
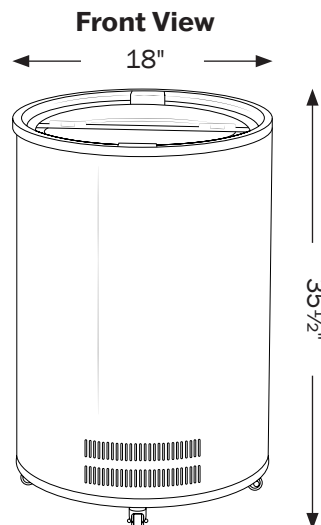
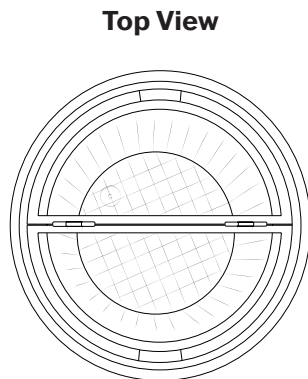

NEMA 5-15P

Dimensions

Exterior Dimensions	18"W x 18"D x 33.5"H
Interior Dimensions	13.85"W x 13.85"D x 22.5"H
Depth with Door Open	22.5"
Net Volume (cu. ft.)	2.25 cu. ft.
Net Weight	46 lb.
Gross Weight	51 lb.
Packaging Dimensions	19.15"W x 19.15"D x 37.15"H

Cooling

Temperature Range	32° to 50°F
Refrigerant	R600a
Max. Ambient Temperature	90°F
Defrosting	Manual
Temperature Controller	Mechanical Thermostat
Horsepower	1/5

Construction

Exterior Material	Galvanized Steel
Interior Material	Aluminum
Door Type	Top Open
Insulation Material	Cyclopentane
Basket	2
Basket Material	PVC Coated
Basket Weight Capacity	66 lb.

Electrical

Voltage	110
Amps	1.5
Hz	60
Phase	1
Plug	USA Plug
Electrical Cord Length	6'

1 Year Limited Replacement Warranty

Unless otherwise stated, Galaxy Equipment warrants to the original purchaser of new, qualified Galaxy Equipment units (and all parts thereof), that such equipment will be free from defects in material and workmanship for a period of 1 year from the date of delivery.

If a qualified product is found to be defective during this period, Galaxy Equipment will repair the defective unit, replace any defective parts, or replace the defective unit.

What This Warranty Does Not Cover:

Galaxy Equipment will not warrant coverage for component failure or other damages that arise under the following conditions:

- Failure to install and/or use the unit within proper operating conditions specified by Galaxy Equipment. This includes installation in any and all outdoor or mobile applications.
- Failure to properly maintain the unit. This includes, but is not limited to, basic preventative maintenance such as cleaning the condenser coil.
- Products sold or used outside of the Continental United States.

Additionally, no claims can be made against this warranty for spoilage of product, loss of sales or profits, or any other consequential damages. Normal wear type parts, such as light bulbs and gaskets, are not included in warranty coverage.

For Warranty Inquiries or Service:

To obtain warranty service, contact the location that you purchased the product from:

www.WebrestaurantStore.com:

Call 717-392-7472. You must have your order number ready when contacting.

The Restaurant Store:

If you purchased this unit from your local store location, please contact your store directly. A list of store locations can be found by visiting: <http://www.therestaurantstore.com/store-directory.html>

www.TheRestaurantStore.com:

If you purchased this unit online, call 717-392-7261. You must have your order number ready when contacting.

Failure to contact the designated location prior to obtaining equipment service may void your warranty.