

PROJECT: _____

MODEL: _____

ITEM #: _____ QUANTITY: _____

APPROVAL: _____ DATE: _____

Item #177BMF3W

2/2021

Barrel Merchandiser Freezer 2.5 Cu. Ft.

Features:

- Digital thermostat sets internal temperature between 0 and -7 °F.
- Operates in an ambient temperature up to 90 °F.
- 2 poly-coated metal baskets hold up to 66 lb.
- LED strip lights up interior of freezer
- Polyurethane foam insulation for temperature retention.
- Includes 4 casters
- Eco-friendly R290 hydrocarbon refrigerant.
- 115V; 1/2 h

Cabinet Construction:

Sturdy design features white galvanized sheet exterior and aluminum interior.

Foamed-in-place CFC- and HCFC-free polyurethane insulation enhances the structural integrity of the cabinet and promotes energy efficiency.

Refrigeration System:

Environmentally safe R290 refrigerant.

Shelving:

Features 2 poly-coated metal baskets that can handle up to 66 lb.

Model Features:

Easy to maneuver with 4 casters.
See-through, flip-top lid for clear product visibility.

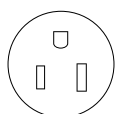
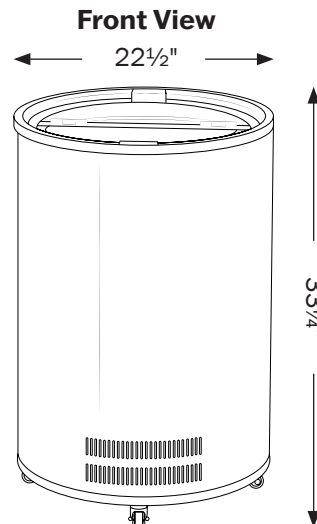
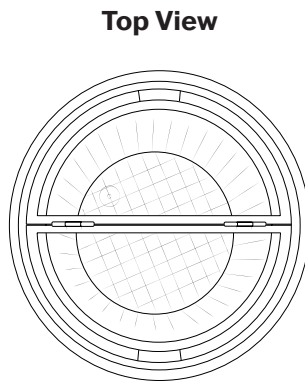

NEMA 5-15P

Dimensions

Exterior Dimensions	22.5"W x 22.5"D x 33.25"H
Interior Dimensions	17.4"W x 17.4"D x 18.3"H
Depth with Door Open	18.3"
Net Volume (cu. ft.)	2.5 cu. ft.
Net Weight	84 lb.
Gross Weight	91 lb.
Packaging Dimensions	23.5"W x 23.5"D x 35.4"H

Cooling

Temperature Range	-4° to -7.6°F
Refrigerant	R290a
Max. Ambient Temperature	90°F
Defrosting	Manual
Temperature Controller	Digital
Horsepower	1/2

Construction

Exterior Material	Galvanized Steel
Interior Material	Aluminum
Door Type	Top Open
Insulation Material	Cyclopentane
Basket	2
Basket Material	PVC Coated
Basket Weight Capacity	66 lb.

Electrical

Voltage	110
Amps	2.3
Hz	60
Phase	1
Plug	USA Plug
Electrical Cord Length	6'

1 Year Limited Replacement Warranty

Unless otherwise stated, Galaxy Equipment warrants to the original purchaser of new, qualified Galaxy Equipment units (and all parts thereof), that such equipment will be free from defects in material and workmanship for a period of 1 year from the date of delivery.

If a qualified product is found to be defective during this period, Galaxy Equipment will repair the defective unit, replace any defective parts, or replace the defective unit.

What This Warranty Does Not Cover:

Galaxy Equipment will not warrant coverage for component failure or other damages that arise under the following conditions:

- Failure to install and/or use the unit within proper operating conditions specified by Galaxy Equipment. This includes installation in any and all outdoor or mobile applications.
- Failure to properly maintain the unit. This includes, but is not limited to, basic preventative maintenance such as cleaning the condenser coil.
- Products sold or used outside of the Continental United States.

Additionally, no claims can be made against this warranty for spoilage of product, loss of sales or profits, or any other consequential damages.

Normal wear type parts, such as light bulbs and gaskets, are not included in warranty coverage.

For Warranty Inquiries or Service:

To obtain warranty service, contact the location that you purchased the product from:

www.WebstaurantStore.com:

Call 717-392-7472. You must have your order number ready when contacting.

The Restaurant Store:

If you purchased this unit from your local store location, please contact your store directly. A list of store locations can be found by visiting: <http://www.therestaurantstore.com/store-directory.html>

www.TheRestaurantStore.com:

If you purchased this unit online, call 717-392-7261. You must have your order number ready when contacting.

Failure to contact the designated location prior to obtaining equipment service may void your warranty.