



Outperform every day.™

Project:  
Item Number:  
Quantity:

Stoelting® Mini Soft Serve Countertop Freezer

The Vollrath Company, L.L.C.

## STOELTING® MINI SOFT SERVE COUNTERTOP FREEZER



Stoelting® Mini Soft Serve Countertop Freezer

### DESCRIPTION

The Vollrath Stoelting® Mini Soft Serve Countertop Freezer makes it easy to add soft serve frozen deserts to any menu. The easy to use machine is ideally suited for small restaurants, delis, bakeries, food trucks and convenience stores.

### Agency Listings



Due to continued product improvement, please consult [www.vollrath.com](http://www.vollrath.com) for current product specifications.

### ITEMS

Item No.	Model No.	Description
CBB116-37	CBB116	Stoelting® Mini Soft Serve Countertop Freezer

### FEATURES

- Freezes and serve commercial soft serve or non-dairy mixes, including: ice milk, ice cream, yogurt, and frozen dietary desserts
- Total Cold refrigeration system keeps product at constant temperature
- Seal-less drive shaft design eliminates preventive maintenance and mandatory seal replacements
- Vertical drive shaft rotates from the top, above the mix, which prevents mix from entering the shaft - easy clean-up and low maintenance.
- Horizontal auger and vertical drive shaft design delivers a consistent, quality and creamy product for every serving
- Horizontal auger continually draws product across and scrapes the freezer plate to eliminate product build-up and waste
- Automatic or manual Night Mode
- Lockable keypad
- Servings counter
- Small footprint, lightweight machine is portable
- Works with dry or liquid soft serve mixes
- Easy disassembly for cleaning
- 5 ft. (1.5 m) cord with plug

### Warranty

The warranty period is 2 years on warranty parts, 3 years on electronics (electronic board), 5 years on major components such as the compressor. See [Vollrath.com](http://Vollrath.com) for full warranty details.

### CLEARANCE AND ENVIRONMENT REQUIREMENTS

- Clearance: 10" (25.4 cm) on the sides
- Ambient temperature: up to 85° F (29.4° C)
- Indoor use only

Approvals	Date



Outperform every day.™

[www.vollrath.com](http://www.vollrath.com)

### The Vollrath Company, L.L.C.

1236 North 18th Street  
Sheboygan, WI 53081-3201 U.S.A.  
Main Tel: 800.624.2051 or 920.457.4851  
Main Fax: 800.752.5620 or 920.459.6573  
Customer Service: 800.628.0830  
Canada Customer Service: 800.695.8560

Technical Services  
[techservicereps@vollrathco.com](mailto:techservicereps@vollrathco.com)  
Induction Products: 800.825.6036  
Countertop Warming Products: 800.354.1970  
All Other Products: 800.628.0832

# STOELTING® MINI SOFT SERVE COUNTERTOP FREEZER

## DIMENSIONS (Shown in inches (cm))

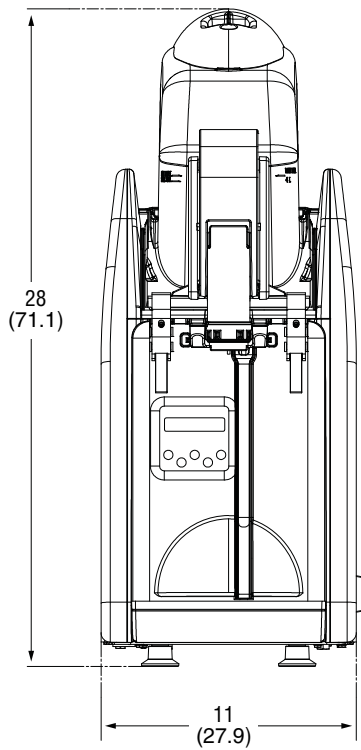

Front View

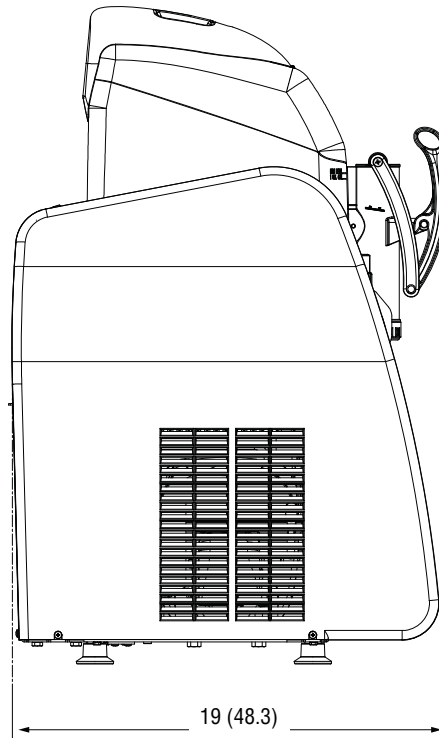

Side View

## SPECIFICATIONS

Item No.	Mix Capacity Gal. (L)	Finished Product Capacity Gal. (L)	Voltage	Amps	Hertz	Compressor HP	Weight Lbs (Kg)	Plug
CBB116-37	1 (3.8)	Up to 1.5 (5.7)	115	10	60	1/3	65 (29.4)	NEMA 5-15P

### Receptacle

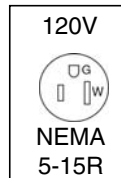

Outperform every day.™

[www.vollrath.com](http://www.vollrath.com)

### The Vollrath Company, L.L.C.

1236 North 18th Street  
 Sheboygan, WI 53081-3201 U.S.A.  
 Main Tel: 800.624.2051 or 920.457.4851  
 Main Fax: 800.752.5620 or 920.459.6573  
 Customer Service: 800.628.0830  
 Canada Customer Service: 800.695.8560

Technical Services  
[techservicereps@vollrathco.com](mailto:techservicereps@vollrathco.com)  
 Induction Products: 800.825.6036  
 Countertop Warming Products: 800.354.1970  
 All Other Products: 800.628.0832