



MODEL SHO-100-E
Full-Size Electric Convection Oven
(Formerly called SHO-E)



OPTIONS AND ACCESSORIES
 (AT ADDITIONAL CHARGE)

- **Legs/casters/stands:**
 - 6" (152mm) seismic legs
 - 6" (152mm) casters
 - 4" (102mm) low profile casters
 - 25" (635mm) stainless steel stand w/rack guides
 - 29" (737mm) stainless steel, fully welded open stand with pan supports
- Extra oven racks
- Flue connector

Project _____

Item No. _____

Quantity _____

Baking compartment - accepts five 18" x 26" standard full-size baking pans in left-to-right position.

All data is shown per oven section, unless otherwise indicated.

Refer to operator manual specification chart for listed model names.

SHO-100-E

EXTERIOR CONSTRUCTION

- Full angle iron frame
- Stainless steel front, top, sides and legs
- 25" (635mm) stainless steel legs for single ovens
- 6" (152mm) stainless steel legs for double stacked ovens
- Dependent stainless steel doors, dual pane thermal glass window
- Tubular black soft touch door handle
- Triple-mounted door hinge pins
- Removable front control panel
- Solid mineral fiber insulation on back, fiberglass insulation on top, sides and bottom

INTERIOR CONSTRUCTION

- Double-sided porcelainized baking compartment liner (14 gauge)
- Aluminized blower wheel
- Five chrome-plated racks, eleven rack positions with a minimum of 1-5/8" (41mm) spacing
- Interior lights

OPERATION

- Three tubular heaters
- Thermostat with temperature control range of 200°F (93°C) to 500°F (260°C)
- Two speed fan
- 1/2 horsepower blower motor with automatic thermal overload protection
- Control area cooling fan

STANDARD FEATURES

- SSM - Solid state manual control with separate dials to control thermostat and timer
- 25" (635mm) adjustable stainless steel legs (for single units)
- 6" (152mm) adjustable stainless steel legs (for double sections)
- One year oven parts and labor warranty*

* For all international markets, contact your local distributor.



BLODGETT OVEN COMPANY

www.blodgett.com • 44 Lakeside Avenue, Burlington, VT 05401 • Phone: (802) 658-6600 • Fax: (802) 864-0183



SHO-100-E

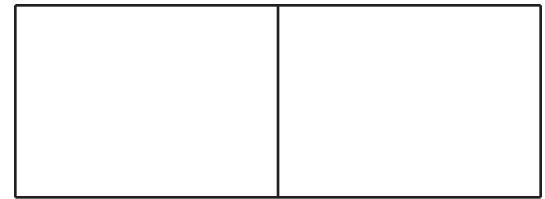

APPROVAL/STAMP

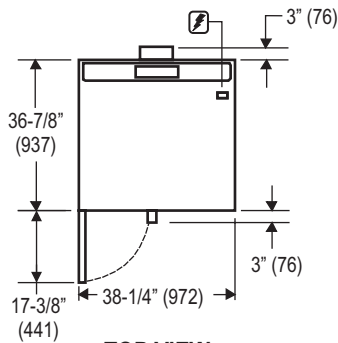

TOP VIEW

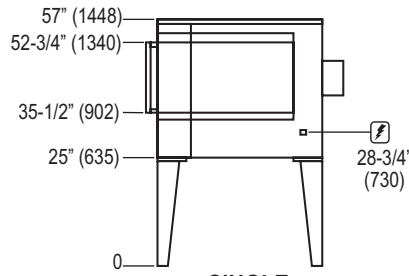

SINGLE

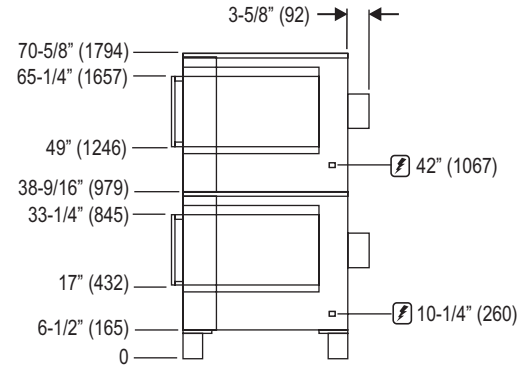

DOUBLE

SHORT FORM SPECIFICATIONS: Provide Blodgett full-size convection oven model SHO-100-E, (single/double) compartment. Each compartment shall have a fully welded angle iron frame. Interior shall have fully coved porcelainized steel liner and shall accept five 18" x 26" standard full-size bake pans in left-to-right position. Door shall be stainless steel with dual pane thermal glass and dependent operation. Left door shall have tubular black soft touch handle. Unit shall be electrically heated with three tubular heaters. Air in baking chamber distributed by dual inlet blower wheel powered by a two-speed, 1/2 HP motor with thermal overload protection. Each chamber shall be fitted with five chrome-plated removable racks and interior lights. Control panel shall be recessed with Cook/Cool Down mode selector switch, electromechanical thermostat, 200 - 500°F (93-260°C), and 60-minute timer. Provide options and accessories as indicated.

DIMENSIONS:

Floor space 38-1/4" (972mm) W x 36-7/8" (936mm) L
 Product clearance 1/2" from combustible and non-combustible construction
 Interior 29" (737mm) W x 20" (508mm) H x 24-1/4" (616mm) D

If oven is on casters:

Single Add 4-1/2" (114mm) to all height dimensions
 Double Dimensions do not change
 Double Low Profile Subtract 2-1/2" (64mm) from all height dimensions

POWER SUPPLY:

208 VAC	60 Hz.	1 phase	11kW	51/0/51 Amperes
208 VAC	60 Hz.	3 phase	11kW	31/29/29 Amperes
220/240 VAC	60 Hz.	1 phase	11kW	44/0/44 Amperes
220/240 VAC	60 Hz.	3 phase	11kW	26/24/24 Amperes
480VAC	60 Hz	3 phase	11kW	14/13/13 Amperes

* At an additional charge

MAXIMUM INPUT:

Single 11KW
 Double 22KW (11KW each section)

MINIMUM ENTRY CLEARANCE:

Uncrated 32-1/4" (819mm)
 Crated 37-3/4" (959mm)

SHIPPING INFORMATION:

Approx. Crated Weight:

Single: 480 lbs. (218 kg)
 Double: 960 lbs. (435 kg)

Crate sizes:

37-1/2" (952mm) x 43-1/2" (1105mm) x 51-3/4" (1315mm)

NOTE: The company reserves the right to make substitutions of components without prior notice

BLODGETT OVEN COMPANY

www.blodgett.com • 44 Lakeside Avenue, Burlington, VT 05401 • Phone: (802) 658-6600 • Fax: (802) 864-0183