

NOR-LAKE, INCORPORATED
 727 Second Street
 P.O. Box 248
 Hudson, Wisconsin 54016

800-955-5253
 715-386-2323
 866-961-5253 Parts
 800-388-5253 Service
 715-386-4291 FAX
 www.norlake.com

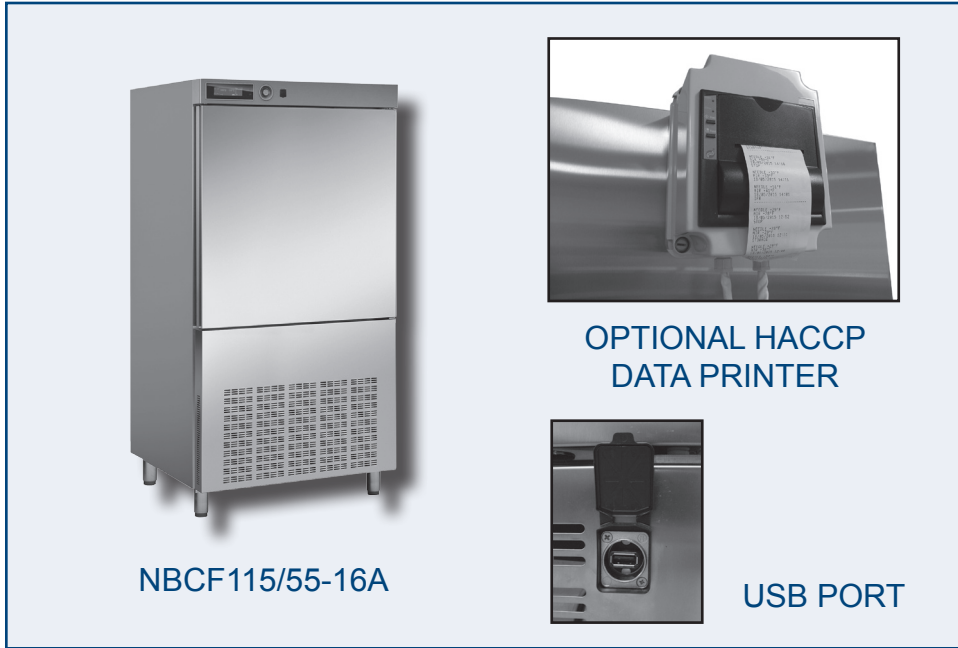

REACH-IN BLAST CHILLERS / FREEZERS



NBCF115/55-16A

OPTIONAL HACCP
DATA PRINTER

USB PORT

PROJECT:

ITEM NUMBER:

MODEL NUMBER:

REACH-IN BLAST CHILLERS / FREEZERS

SPECIFICATIONS FOR: NBCF99/59-8A, NBCF115/55-16A, NBCF220/110-16A

- **Exterior Finish:** Stainless steel exterior; satin scotchbrite finish on door, side panels and control panel.
- **Interior Finish:** Stainless steel; one-piece construction with rounded internal corners
- **Insulation:** The complete cabinet and door(s) are foamed-in-place with CFC-free polyurethane insulation.
- **Hardware:** Removable stainless steel wire racks with 1.2" vertical spacing intervals (23 on NBCF99/59-8), (25 on NBCF115/55-16A & NBCF220/110-16A); pan guide sets (8 with NBCF99/59-8), (10 with NBCF115/55-16A & NBCF220/110-16A); plastic defrost drip tray on outer base; stainless steel feet adjustable from 5.9" to 7.9"; standard product core L-shaped probe for easy extraction; self-closing door with full-height outer stainless steel handle; removable magnetic gasket; door frame heating element.
- **Electrical:** 220/60/3
- **Instrumentation:** LCD control board with USB port, encoder, multi-lingual, multi-sector; blast chilling with variable cycle progression; 20 pre-set blast-chilling cycles; displays interior temperature, product temperature and ventilation speed; maintain temperature at end of blast chilling/freezing cycle.
- **Refrigeration:** R-404a refrigerant; evaporator temperature control with thermostatic valve; hinged evaporator coil cover for easy cleaning of evaporator coil; copper/aluminum corrosion-proofed evaporator coil; electronically controlled, electric defrost; drain outlet for easy interior cleaning. Note: Models NBCF115/55-16A and NBCF220/110-16A need to be plumbed to a floor drain. Scheduled or time cycled proving for food leavening. The chilling process will take product from +194°F to +37°F in 90 minutes and the freezing process will take product from +194°F to 0°F in 240 minutes.
- **Approvals:** ETL Safety and Sanitation listed **

STANDARD FEATURES

- Adjustable feet
- CFC-free polyurethane insulation
- Copper/aluminum corrosion resistant evaporator
- Door frame heater
- Electronically controlled, electrical defrost
- Hermetic compressor
- L-shaped probe

- LCD control board
- R-404a refrigerant
- Removable magnetic door gasket
- Reversible door
- Stainless steel exterior
- Stainless steel half racks
- Stainless steel, polished interior
- ETL Safety & Sanitation listed **
- Warranties: 1 year parts and labor, 5 year compressor

OPTIONAL FEATURES *

- Additional pan guides
- Additional wire shelves
- HACCP data printer

* Most options are available one week from receipt of order. Please contact us for specific questions.

** ETL Sanitation is Intertek Labs Certification Mark which indicates that ETL has tested the equipment to applicable NSF Standards.

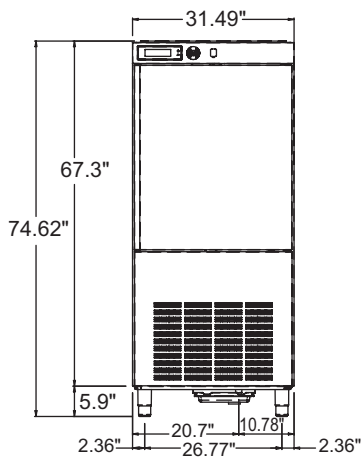

**NBCF99/59-8A
FRONT VIEW**

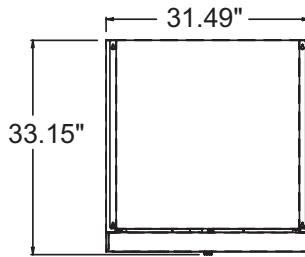

**NBCF99/59-8A
TOP VIEW**

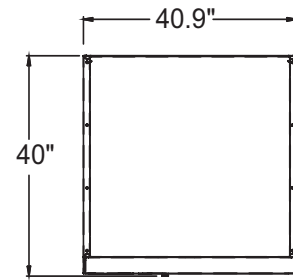

**NBCF115/55-16A
NBCF220/110-16A
TOP VIEW**

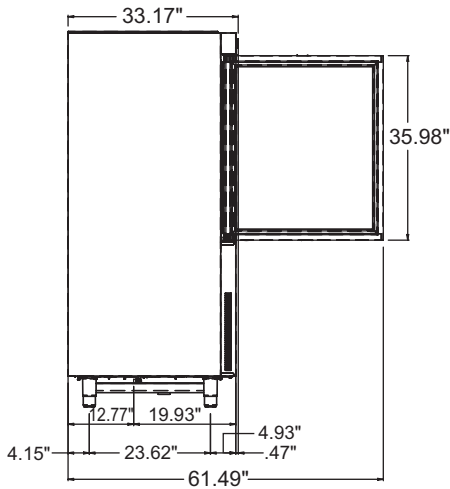

**NBCF99/59-8A
SIDE VIEW**

SPECIFICATIONS

<i>Models</i>	<i>NBCF99/59-8A</i>	<i>NBCF115/55-16A</i>	<i>NBCF220/110-16A</i>
<i>Crated Weight (lbs) (kg)</i>	453 (206)	541 (246)	651 (296)
<i>Crated Height (in) (cm)</i>	85 (215)	85 (215)	85 (215)
<i>Crated Width (in) (cm)</i>	35-1/8 (91)	42-1/2 (108)	42-1/2 (108)
<i>Crated Depth (in) (cm)</i>	35 (88)	42-1/2 (108)	42-1/2 (108)
<i>Overall Height (in) (cm)</i>	74-5/8 (187)	78 (195)	78 (195)
<i>Overall Width (in) (cm)</i>	31-1/2 (79)	40-15/16 (102)	40-15/16 (102)
<i>Overall Depth (in) (cm)</i>	33-1/8 (84)	40 (102)	40 (102)
<i>Number of Shelves</i>	3	6	10
<i>Shelf Size (in)</i>	15.7 x 23.6	31.5 x 23.6	31.5 x 23.6
<i>Max Pan Capacity</i>			
<i>12" x 20" x 2.5"</i>	8	16	16
<i>12" x 20" x 1.5"</i>	12	26	26
<i>18" x 26" x 2.5"</i>	-	8	8
<i>18" x 26" x 1.5"</i>	-	13	13
<i>Number of Legs</i>	4	4	4
<i>Condensing Unit Size</i>	3 HP	3 HP	5.5 HP
<i>Refrigerant</i>	R-404a	R-404a	R-404a
<i>Electrical Characteristics</i>	220/60/3	220/60/3	220/60/3
<i>Cord & Plug Furnished</i>	No	No	No
<i>Total Amp Draw</i>	12.5	14.0	17.5

Specifications subject to change without notice.

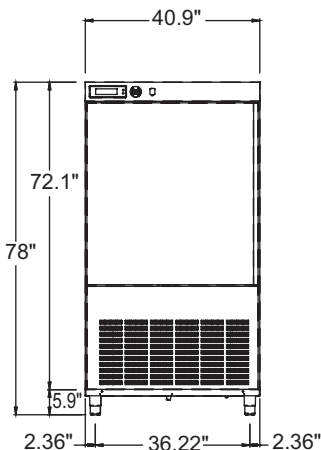

**NBCF115/55-16A
NBCF220/110-16A
FRONT VIEW**

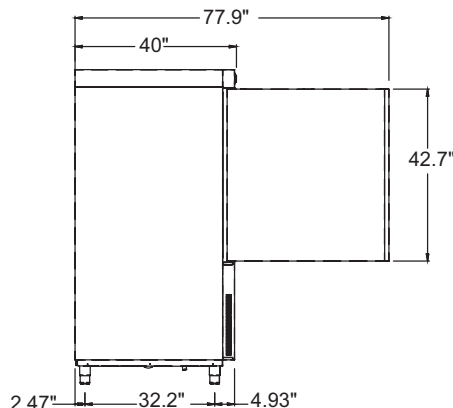

**NBCF115/55-16A
NBCF220/110-16A
SIDE VIEW**



NORLAKE[®]

Revision Date: 05/15
© 2015 NOR-LAKE, INC.
Printed in the U.S.A.
Part Number: 143350

