



BEVERAGE-AIR.

Project: _____	AIA#
Item: _____	SIS#
Location: _____	
Approved: _____	

MARKETEER™ MERCHANDISERS

MT49 White Hinged Door Model

Hydrocarbon Series

MODEL:
MT49-1W

MT49™ MERCHANDISER: HINGED DOOR MODEL



3 Year Parts/Labor Warranty
5 Year Compressor Warranty

CABINET CONSTRUCTION

- Standard cabinet exterior finish is heavy duty steel with a white baked on durable coating
- Heavy duty interior construction includes white coated steel
- Mechanical temperature control
- Modern one piece grille
- Double pane lowE argon filled glass door feature outside pane that is tempered for added safety
- Door locks standard
- Self-closing hinged glass door features, pocket door handles
- LED lighting
- Ten (10) epoxy coated shelves
- Leveling feet

OPTIONS & ACCESSORIES

- Extra shelves and clips
- 3" Casters
- Visislide shelving kit

REFRIGERATION SYSTEM

- Uses environmentally friendly, energy efficient R290 refrigerant, and meets all regulatory requirements for CARB, SNAP, DOE & more
- Condenser is designed to be low maintenance, and energy efficient
- Automatic, non-electric defrost
- Epoxy coated evaporator coil



Please verify qualifying units by visiting:
www.energystar.gov/cfs

3779 Champion Blvd., Winston-Salem, NC 27105
1-888-845-9800 Fax: 1-336-245-6453
Beverage-Air.com Sales@bevair.com



BEVERAGE-AIR.

MODEL		MT49-1W
EXTERNAL DIMENSIONAL DATA		
Width Overall		47 1/8"
Depth Overall		29 3/16"
Height Overall		78 3/8"
Number of Doors		2
Depth with Door Open 90°		49 5/8"
Door Openings		19 3/8" x 60 7/16"
INTERNAL DIMENSIONAL DATA		
NET Capacity (cubic ft.)		37.42
Capacity 20 oz		490
Internal Width Overall (in)		43"
Internal Depth Overall (in)		23 1/4"
Internal Height Overall (in)		60 1/2"
Internal Height Useable (in)		54 13/16"
Number of Shelves		10
ELECTRICAL DATA		
Full Load Amperes 115/60/1		8.3
REFRIGERATION DATA		
Horsepower		1/2
Energy Consumption		5.170 kWh/day
Capacity (BTU/Hr)		3615
Heat Rejection (BTU/Hr)		5422.5
Charge (lbs/grams/ounces)		0.2094 / 95 / 3.35
WEIGHT DATA		
Gross Weight - Crated		448 lbs
Height - Crated		86"
Width - Crated		50"
Depth - Crated		34"

We reserve the right to change specifications and product design without notice. Such revisions do not entitle the buyer to corresponding changes, improvements, additions or replacements for previously purchased equipment. Dimensional tolerances +/- 1/4". Metric dimensions (MM).

Glass Hinged Door Model Model: MT49-1W

Model Views

Required Clearance: 4" Top, Bottom, Rear, & Sides

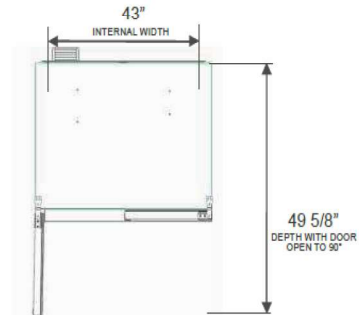

PLAN VIEW

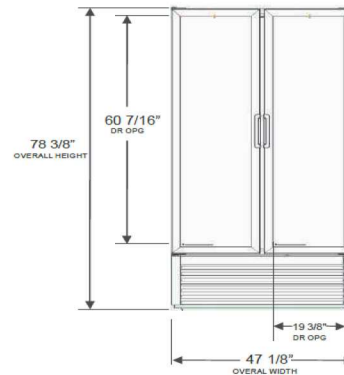

ELEVATION VIEW

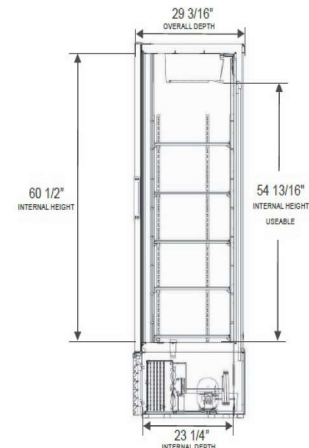

SIDE VIEW

ELECTRICAL CONNECTION



115/60/1
NEMA 5-15P

Unit pre-wired at factory and include 8' long cord and plug set.

