



Project \_\_\_\_\_

Item 541FF40L Quantity \_\_\_\_\_

Approval \_\_\_\_\_ Date \_\_\_\_\_

## Main Street Equipment Liquid Propane 40 lb. Stainless Steel Floor Fryer - 90,000 BTU

Item #541FF40L

### Special Features

- All stainless steel tank, door, front, top, ledge, and header; galvanized steel sides
- Easy-to-use thermostat for accurate and adjustable temperature between 200-400 degrees Fahrenheit
- 40 lb. fry pot with an efficient and quiet 3 tube burner system and full port drain
- Two nickel chrome wire mesh fry baskets included
- Liquid propane, 90,000 BTU

### Technical Data

Width	15 1/2 Inches
Depth	30 1/4 Inches
Height	47 1/8 Inches
Fry Pot Width	14 Inches
Fry Pot Depth	13 3/4 Inches
Burner Style	Tube
Cabinet	Galvanized and Stainless Steel
Capacity	40 lb.
Control Type	Millivolt
Gas Inlet Size	3/4 Inches
Number of Burners	3 Burners
Number of Fry Baskets	2 Fry Baskets
Number of Fry Pots	1 Fry Pots
Power Type	Liquid Propane
Temperature Range	200 - 400 Degrees F
Temperature Settings	Adjustable
Total BTU	90000 BTU
Type	Gas Floor Fryers



### Certifications



ETL Sanitation



ETL US & Canada



3/4" Gas Connection

Technical Drawing

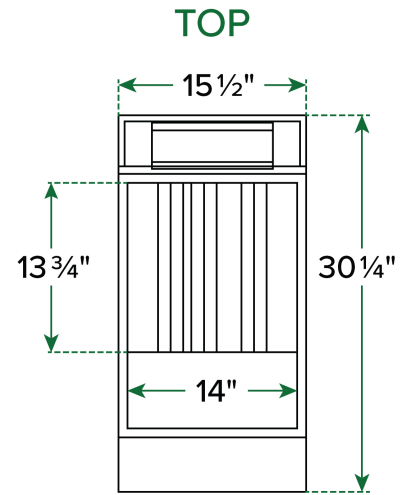
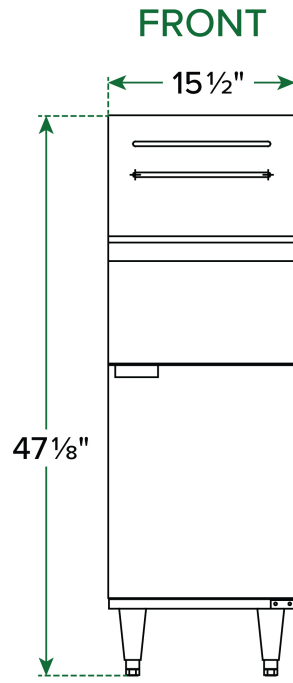
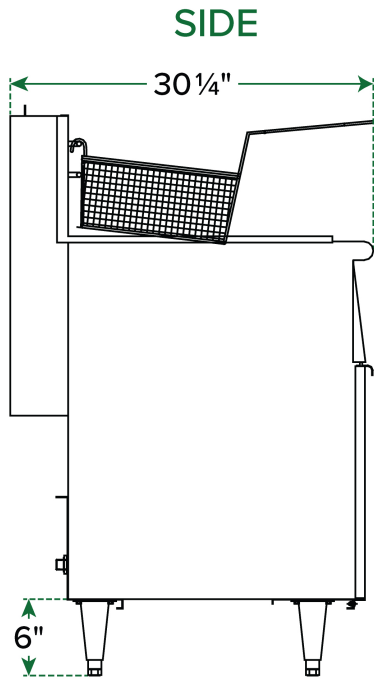

**WARNING:** This product can expose you to chemicals including lead, which are known to the State of California to cause cancer, birth defects, or other reproductive harm. For more information, go to [www.p65warnings.ca.gov](http://www.p65warnings.ca.gov).