



**KLS-G**  
Gas Quad-Leg Stationary Kettle



**KLS-G QUAD-LEG STATIONARY KETTLE**

Project \_\_\_\_\_

Item No. \_\_\_\_\_

Quantity \_\_\_\_\_

- Model KLS-80G - 80 gallon (303 litres) gas stationary kettle
- Model KLS-100G - 100 gallon (379 litres) gas stationary kettle

**CONSTRUCTION**

- 304 stainless steel construction
- 2/3 jacketed with factory sealed distilled water enclosure
- Stainless steel control housing

**OPERATION**

- Integrally mounted controls
- Power switch
- Direct immersion thermostat
- Water sight glass
- Cook indicator light
- Pressure gauge
- Safety gas shutoff valve
- Low water light
- Low water shut off
- Pressure relief valve
- Electronic ignition
- Pressure switch
- 165-265°F (74-130°C) temperature range

**STANDARD FEATURES**

- Manual control
- 6" (152 mm) stainless steel adjustable legs
- 2" tangent draw off
- Spring assist hinged stainless steel cover
- Stainless steel faucet bracket
- 115 VAC, 1 phase, 60 Hz
- One year parts and labor warranty\*

\* For all international markets, contact your local distributor.



**OPTIONS AND ACCESSORIES**

(AT ADDITIONAL CHARGE)

- **Faucets**
  - Single pantry faucet with swing spout
  - Double pantry faucet with swing spout
- **Draw Off valves and accessories**
  - 3" (76mm) draw off valve
  - 3" (76mm) dairy valve
  - Perforated strainer for draw off
  - Solid disk strainer for draw off
- **Etched markings**
  - Gallons
  - Litres
- 208-240 VAC, 1 phase, 60 Hz
- Correctional package
- 316 stainless steel liner
- Graduated measuring strip
- Strainer hook
- Tri-basket assembly
- Casters

**BLODGETT**

[www.blodgett.com](http://www.blodgett.com)

44 Lakeside Avenue, Burlington, VT 05401 • Phone: (802) 658-6600 • Fax: (802) 864-0183



# KLS-G QUAD-LEG STATIONARY KETTLE



APPROVAL/STAMP

DIMENSIONS ARE IN INCHES [MM]

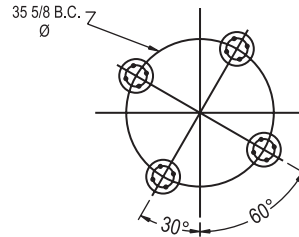
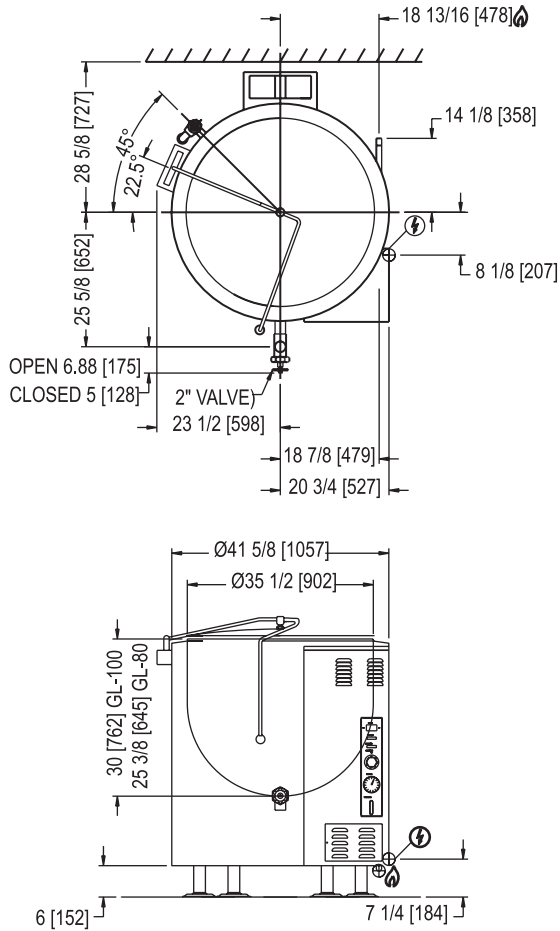

**FLANGED FOOT DETAIL**  
4 EQUALLY SPACED  
Ø7/16" [11mm] HOLES  
ON 3 [76] B.C.

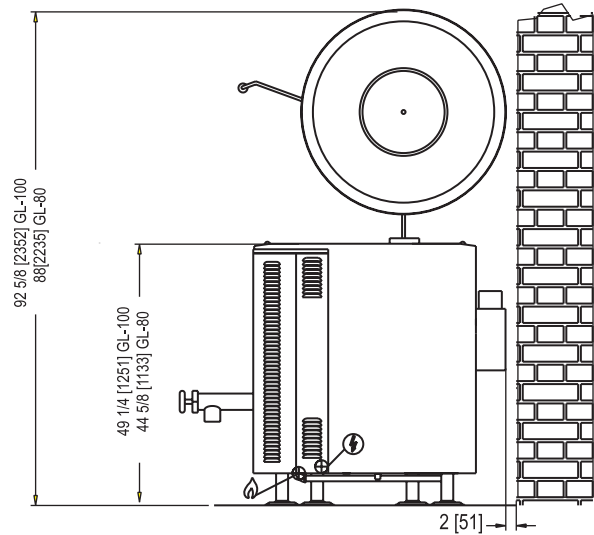

## SHORT FORM SPECIFICATIONS

Provide Blodgett model KLS-80G (80 gallon) or KLS-100G (100 gallon) gas fired tri-leg stationary kettle. The unit shall have a double wall interior to form a steam jacket around the lower 2/3 of the kettle. The jacket enclosure shall contain distilled water which is factory sealed. The bottom of the kettle shall be of hemispherical design for superior heat circulation. Construction shall be of all welded satin finish 304 stainless steel. The unit shall have 6" stainless steel adjustable legs, a 2" tangent draw off valve, and a spring assist cover. The recessed control panel is located on the front side of the unit in full view of the operator and is easy to use. The controls shall be integrally mounted and shall include a power switch, electronic ignition, direct immersion thermostat with a range of 165-265°F (74-130°C), a cook indicator light, pressure gauge, safety gas shutoff valve, pressure relief valve, low water light and low water shut off. Unit shall be ASME code stamped and National Board registered. Provide options and accessories as indicated.

## MAXIMUM INPUT:

KLS-80G 150,000 BTU  
KLS-100G 150,000 BTU

## POWER SUPPLY:

115VAC, 1 phase, 60 Hz., 2-wire w/ground - 6' (1.8m) electric cord set furnished  
208-240VAC, 1 phase, 60 Hz - Supply must be wired to unit

## GAS SUPPLY:

One 1" male connection required  
**Minimum Inlet Pressure:**  
Natural 7.0" W.C. static to unit  
Propane 11.0" W.C. static to unit

## SHIPPING INFORMATION:

**Approx. Weight:**  
KLS-80G 1000 lbs. (454 kg)  
KLS-100G 1150 lbs. (522 kg)

**NOTE:** The company reserves the right to make substitutions of components without prior notice.

**BLODGETT**

[www.blodgett.com](http://www.blodgett.com)

44 Lakeside Avenue, Burlington, VT 05401 • Phone: (802) 658-6600 • Fax: (802) 864-0183