



Symphony Plus™ ice and water dispenser

25 & 50 HI series wall mount with Chewblet® ice machine

Features

25 or 50 lb (11.4 or 22.7 kg) ice storage capacity

Removable air-cooled ice machine with up to 425 lb (193.0 kg) daily production of popular Chewblet ice

- soft, chewable, compressed nugget ice is preferred over cubes¹ and is ideal for patient care

New - Quiet Night™ sleep mode turns off ice machine when idle

Designed with sanitation in mind

New - automatic self-flushing of ice machine removes impurities

New - drain cup provides internal air gap for added protection of food zone components from drain line contaminants

- Agion® silver-based antimicrobial provides protection of key ice and water contact components²

- SensorSAFE™ infrared ice dispense

Reliable design, easy to service and clean

New - cleaning and sanitizing of entire machine takes only 1 hour

New - LED control board provides at-a-glance machine status

- panels are easily removed for accessibility to all components

- ice machine parts are common across all Symphony Plus dispensers

- stainless steel evaporator and auger deliver long life

Environmentally responsible

- meets Consortium for Energy Efficiency Tier 2 specifications
- R404a refrigerant has zero ozone depletion potential
- ice-only dispensers are ENERGY STAR® certified
- continuous ice making process uses less electricity and water

Durable, attractive dispenser

- frame and exterior cabinet are stainless steel with accent trim
- poly drain pan, grille and dispenser lid are corrosion-resistant

New - secured top lid

Easy installation and industry's best warranty

- comes fully assembled and installs with three easy connections – electric, water and drain

- warranty – 3 years parts and labor, 5 years compressor parts

Accessories

SafeCLEAN™ environmentally responsible ice machine cleaner (item# 00132001)

Nu-Calgon® IMS-II sanitizer, 16 oz bottle (item# 00979674)

Additional filters (refer to form# 6380, # 9905, # 6070)

Additional Symphony Plus accessories (refer to price list)

Ice and water dispensers, 115V/60 Hz			
Ice storage capacity	Dispense	Ice machine cooling	Item number
25 lb (11.4 kg)	SensorSAFE	air	25HI425A-S0-00
			25HI425A-S0-DP*
50 lb (22.7 kg)	SensorSAFE	air	50HI425A-S0-00
			50HI425A-S0-DP*

* Units configured with drain pan
Ice-only available, replace -S0 with -SI
Example: 25HI425A-SI-00



Ice production		
Temperatures air/water	70/50 F (21/10 C)	90/70 F (32/21 C)
Air-cooled	425 lb (193.0 kg)	325 lb (147.6 kg)
Energy consumption per 100 lb (45.4 kg) ice	N/A	6.3 kWh air-cooled
Water consumption	12.0 gal (45.4 L) of potable water per 100 lb (45.4 kg) of ice	

Job

Item

Specification

Ice storage capacity	25 Series – 25 lb (11.4 kg), 50 Series – 50 lb (22.7 kg)
W1 Width	21.50" (54.6 cm)
D1 Depth, upper cover	24.50" (62.2 cm)
D2 Depth, bottom	17.00" (43.2 cm)
H1 Height	25 Series – 36.50" (92.7 cm), 50 Series – 40.50" (102.9 cm)
Ventilation clearance	3.00" (7.62 cm) all sides
Service clearance	12.00" (30.5 cm) top, 6.00" (15.24 cm) left side
C1 115 V/60/1 electrical	11 amps, 0.8 kW 7' (2.1 m) cord, NEMA 5-15 90° hospital-grade plug
C2 Potable water inlet	3/8" FPT
C3 Drain	3/4" MPT
Utility connection location	back or bottom
K1 Minimum span – wall bracing required in most applications	16.00" (40.6 cm) on center NOTE: Wall mount bracket standard
K2 Maximum height from sink	18.00" (45.7 cm)
K3 Minimum distance from wall to front of sink	30.00" (76.2 cm)
K4 Minimum sink width	21.00" (53.3 cm) centered on dispenser, 14.50" (36.8 cm) centered on chutes
K5 Minimum sink depth	16.00" (40.6 cm)
Air temperature	50 - 100 F (10 - 38 C) indoor use only
Water temperature	45 - 90 F (7 - 32 C)
Water pressure	10 - 70 psi (69 - 483 kpa)
Heat rejection	5000 BTU/hr
Water consumption	12.0 gal (45.4 L) of potable water per 100 lb (45.4 kg) of ice
Approximate ship weight	255 lb (116 kg)

NOTE: For indoor use only

SHORT FORM SPECIFICATION: (Choose one) ___ Ice and water or ___ ice-only dispenser to be Follett® automatic load in wall mount configuration, with ___ 25 lb (11.4 kg) or ___ 50 lb (22.7 kg) of storage. Environmentally responsible R404a ice machine to be air-cooled and to be removable for cleaning and maintenance. Dispenser frame and cabinet to be stainless steel with plastic trim. Ice machine to produce approximately 425 lb (193.0 kg) of Chewblet compressed nugget ice at air temp. of 70 F (21 C), water temp. of 50 F (10 C). Ice machine to be equipped with automatic self-flushing and Quiet Night sleep mode. Dispenser to have automatic bin level control to start and stop ice machine and lightweight plastic top that allows full access to the ice storage area for easy cleaning and manual loading of back-up ice. Storage area to be insulated with non-CFC, high density, foamed-in-place polyurethane. 7' (2.1 m) cord and NEMA 5-15 90° hospital-grade plug provided. NSF and ETL listed.

Dimensional drawing

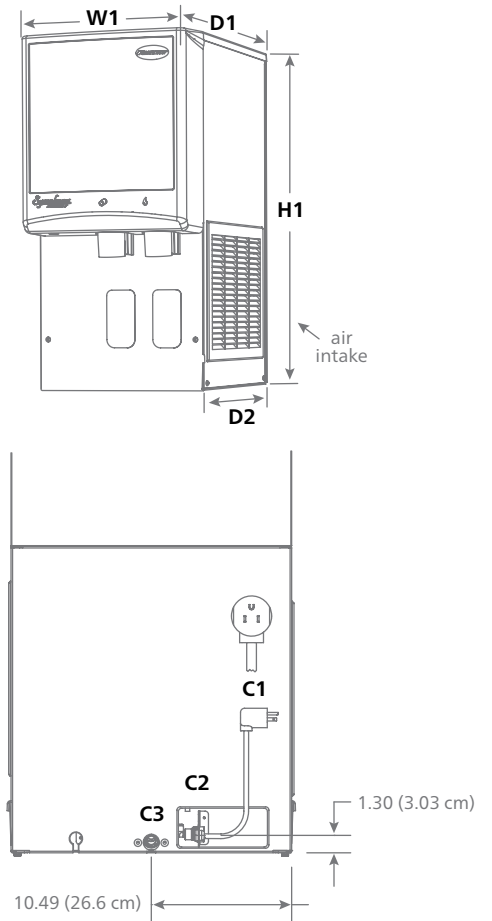

Wall mount detail

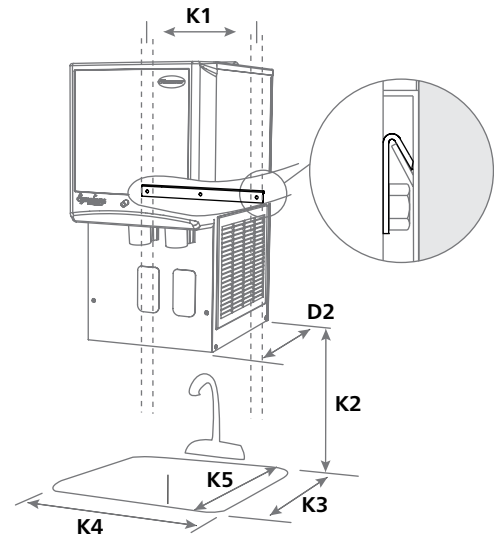

- 1 Independent third party studies. Contact Follett for details.
- 2 Disclaimer: Antimicrobial protection is limited to the treated components and does not treat water or ice.
- 3 Factory installed accessories must be specified at time of order. Agion is a registered trademark of Sciessent LLC. ENERGY STAR and the ENERGY STAR mark are registered US marks. Calgon is a licensed tradename distributed by Nu-Calgon, in the United States. Symphony Plus, SensorSAFE, SafeCLEAN and Quiet Night are trademarks of Follett Corporation. Chewblet and Follett are registered trademarks of Follett Corporation, registered in the US. Follett reserves the right to change specifications at any time without obligation. Certifications may vary depending on country of origin.

25/50 HI series wall mount