

# DROP-IN SEALED WELL ELECTRIC UNIT



DISW-4-240 Shown

Item #: \_\_\_\_\_ Qty #: \_\_\_\_\_  
 Model #: \_\_\_\_\_  
 Project #: \_\_\_\_\_

### FEATURES:

- Fiberglass insulation between each compartment
- 12" x 20" die stamped openings
- Full stainless steel construction inside and out.
- Remote control panel
- Units are supplied with drains for wet or dry application
- Includes 1" I.P.S. Drain(s) with Gate Valve

### MATERIAL:

- TOP:** 18 gauge #304 stainless steel with die stamped pan openings and self rimmed. (12" x 20" opening)
- BODY:** 20 gauge galvanized



### ELECTRICAL:

- 120V units yield 1100 Watts
- 208V/240V dual voltage units yield 825 Watts at 208V and 1100 Watts at 240V
- Infinite control knobs
- Indicator lights

**Unit to be hard wired in the field. See Below for optional Cords. Please consult the factory for more information.**

Model #	Length	Width	# of Wells	Cut-Out Size	Volts	Amps	Watts	Approx. Wt.	Cu. Ft.
DISW-1-120	18-13/16"	26-3/4"	1	23-3/8" x 17-1/4"	120	9.17	1100	73 lbs.	6
DISW-2-120	34-1/8"	26-3/4"	2	23-3/8" x 32-5/8"	120	12.34	2200	110 lbs.	6
DISW-3-120	49-7/16"	26-3/4"	3	23-3/8" x 47-7/8"	120	27.51	3300	135 lbs.	6
DISW-1-240	18-13/16"	26-3/4"	1	23-3/8" x 17-1/4"	208/240	3.97/4.58	825/1100	73 lbs.	6
DISW-2-240	34-1/8"	26-3/4"	2	23-3/8" x 32-5/8"	208/240	7.94/9.16	1650/2200	110 lbs.	6
DISW-3-240	49-7/16"	26-3/4"	3	23-3/8" x 47-7/8"	208/240	11.91/13.74	2475/3300	135 lbs.	18
DISW-4-240	64-3/4"	26-3/4"	4	23-3/8" x 63-1/4"	208/240	15.88/18.32	3300/4400	180 lbs.	23
DISW-5-240	80-1/16"	26-3/4"	5	23-3/8" x 78-1/2"	208/240	19.85/22.90	4125/5500	208 lbs.	35
DISW-6-240*	95-3/8"	26-3/4"	6	23-3/8" x 93-7/8"	208/240	23.82/27.48	4950/6600	275 lbs.	35

\*6-well units include two sets of control panels

**NOTE: Units are not designed to cook or heat frozen or refrigerated foods. Food placed in tables should already be hot, and the table will maintain the proper temperatures**

## Optional Accessories:

Visit our website for additional Food Table Accessories



**Manifold Drains (Per Well)**  
 Add The Suffix **-M** To The Model Number.

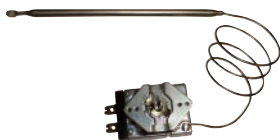





**Thermostatic Controls**  
 Add The Suffix **-T** To The Model Number.



**Adapter Bars**  
**SU-45A** 12" x 1" Adapter Bar.

**3-Phase Upgrade**  
**SU-72** Upgrade to 240 volt units to 3 Phase Wiring.

### Cord with NEMA Plugs

<b>SU-P-234</b>	6' with <b>NEMA 5-15P</b> plug for 1 well, 120v Units	 NEMA 5-15P
<b>SU-P-231</b>	6' Cord & <b>NEMA L5-30P</b> plug for 2 or 3 well, 120v Unit	 NEMA L5-30P
<b>SU-P-232</b>	6' Cord & <b>NEMA 6-20P</b> plug for 1, 2, 3 or 6 well (6 well unit requires 2 Cords), 240v Units	 NEMA 6-20P
<b>SU-P-233</b>	6' Cord & <b>NEMA L6-30P</b> plug, for 4 or 5 well, 240v Units	 NEMA L6-30P

# DIMENSIONS and SPECIFICATIONS

TOL ± .125"

ALL DIMENSIONS ARE TYPICAL

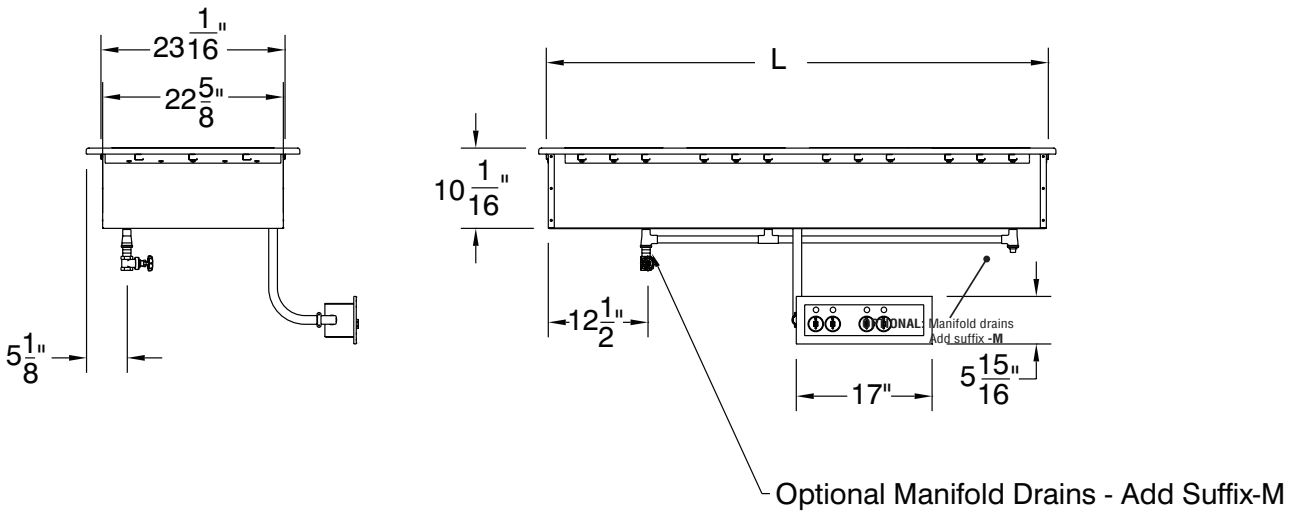
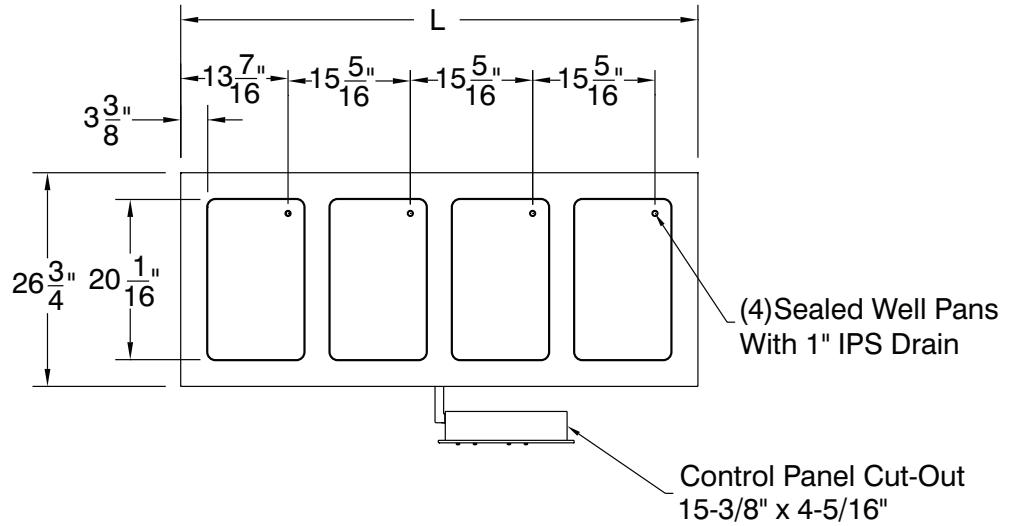

### CONTROL PANEL SPECS

Model #	Cut-Out Size Length (A)	Cut-Out Size Height (B)	Front Panel Length (C)
DISW-1	9 -1/2"	4 -5/16"	11 -1/8"
DISW-2	9 -1/2"	4 -5/16"	11 -1/8"
DISW-3	15 -3/8"	4 -5/16"	17"
DISW-4	15 -3/8"	4 -5/16"	17"
DISW-5	15 -3/8"	4 -5/16"	17"
DISW-6*	15 -3/8"	4 -5/16"	17"

*\*6-well units include two sets of control panels*

**Unit to be hard wired in the field. See Accessories for optional Cords.  
Please consult the factory for more information.**

