

DHB2PT-60P DEDICATED HOLDING BIN



DHB2PT-60P

Prince Castle's DHB2PT-60P Dedicated Holding Bin is designed to hold fried foods at a safe serving temperature while keeping them hot and fresh. The DHB2PT-60P serves as a powerful merchandiser for your customers.

Prince Castle Dedicated Holding Bins are ideal for almost any operation, especially those preparing and holding food prior to serving. Using patented Reli-A-Temp™ heating technology, Prince Castle DHBs keep exterior bin surfaces cool while food is held at proper serving temperatures and moisture levels. Users of Prince Castle DHBs have realized many benefits, including better food quality, longer holding times, reduced food waste and heater equipment reliability.

Each cavity's temperature is digitally-controlled by Prince Castle's time-tested technology, ensuring that food is always being held at desired temperatures, making HACCP and ServSafe programs easier to implement.

FEATURES

- Holds fried foods longer and more consistently with less degradation.
- Pass-thru design for access from front and back.
- Easily accommodates six standard size baskets and six full size sheet pans.
- Exclusive Reli-A-Temp™ infrared heaters provide consistent temperature for an ideal holding environment.
- Independent heating system per cavity.
- Solid state digital controls.
- On/Off main power switch.
- Stainless steel and aluminum construction.
- One-year warranty.

TEMPERATURE ADJUSTMENT:

- Heater power can be individually adjusted for each of the four heaters in increments of 5%.

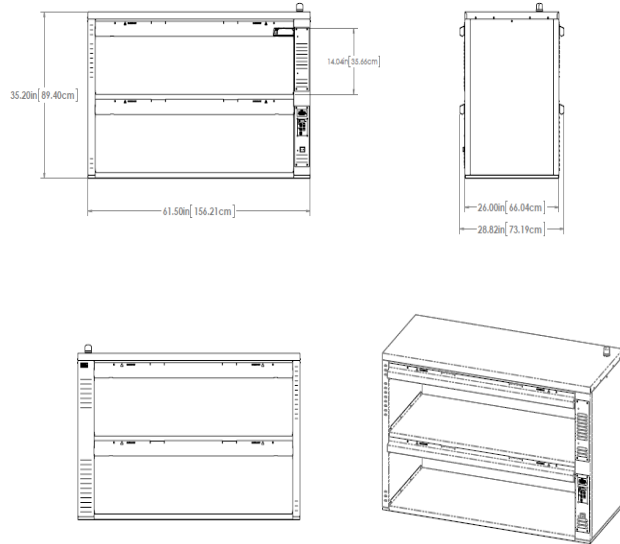

DIMENSIONS

Model Number	Width in (cm)	Height in (cm)	Depth in (cm)	Shipping Weight lb (kg)	# of Independently Controlled Heaters
DHB2PT-60P	61.5 (156.21)	35.2 (89.79)	26.00 (66.04)	320.00 (145.14)	4

ELECTRICAL INFORMATION

Model Number	Phase	Volts	Hz	Watts	Amps	Plug Number
DHB2PT-60P	3	208-240	50/60	6900	26	Not included

CERTIFICATIONS



Designs and Specifications are subject to change without notice.