

BASE MODEL REFRIGERATOR

Model: CRA118

118" Worktop Refrigerator with Solid Doors

Heavy gauge #300 Series stainless steel top, stainless steel front and end panels, galvanized steel rear and grill and aluminum interior.

Designed to maintain NSF-7 temperatures in 100°F ambient.



Options and Accessories

(upcharge and lead times may apply)

Drawers in lieu of doors	Condensing unit left or right
Drawer section above the condensing unit*	Stainless steel pan slides
Additional epoxy-coated steel shelves	Remote models
Stainless steel shelves	Door locks
Automatic, electric condensate evaporator	Adjustable legs
Exterior dial or digital thermometer	Front breathing
Stainless steel back and interior	

*Drawer section above condensing unit holds (1) 12 x 20 x 6 pan

NOTE: 118" overshelves, not available

Project Name:

Model Specified:

Location:

Item No:

Quantity:

AIA #:

SIS #:

Standard Model Features

REFRIGERATION SYSTEM

Performance-rated refrigeration system

Environmentally-safe R-134a refrigerant

Unique forced air design utilizes fans (approx. every 12") across the entire back of unit for even distribution of cold

Automatic, energy saving, non-electric condensate evaporator

Non-corrosive, plasticized fin evaporator coil

Easily serviceable, slide-out condensing unit

CABINET ARCHITECTURE

2" non-CFC polyurethane foam insulation

Spring loaded, self closing doors

Magnetic snap-in door gaskets

Heavy-duty, epoxy-coated steel shelves

5" casters

Completely enclosed, vented and removable rear and side grills

Refrigerated door section above the condensing unit

MODEL FEATURES

Expansion valve for quick recovery

Built-in, off cycle defrost timer

Interior hanging thermometer

Field rehingeable doors

NOTE: CRA models come standard with a door over the condensing unit. A drawer over the condensing unit is an option.

Continental
Refrigerator

Toll-Free: 800-523-7138
Phone: 215-244-1400
Fax: 215-244-9579

539 Dunksferry Road
Bensalem, PA 19020
www.continentalrefrigerator.com

APPROVAL:

Model Specifications

DIMENSIONAL DATA

Net Capacity (cu. ft.)	44 (1246 cu l)
Width, Overall (in.)	118 (2997 mm)
Depth, Overall (in.) (incl. handles & bumpers)	36 1/16 (916 mm)
Height, Overall (in.) (incl. 5" casters)	35 (889 mm)
Shelf Area (sq. ft.)	18.4 (1.7 sq m)
No. of Shelves	8
No. of Full Doors	4
No. of Half Doors	1
Interior Depth (in.)	30 (762 mm)
Interior Height (in.)	26 (660 mm)
Interior Height (in.) (above condenser)	12 1/2 (318 mm)
Interior Width (in.)	114 (2896 mm)

REFRIGERANT DATA

Condensing Unit Size (H.P.)	1/2
Capacity (BTU/Hr)*	5600

ELECTRICAL DATA

Voltage (int'l)	115/60/1 (220/50/1)
Fans	6
Total Amps (int'l)	15.2 (n/a)
10 ft. Cord/Plug [attached] (int'l)	Yes (No)

SHIPPING DATA

Weight (lbs.)	705 (320 kg)
Height - Crated (in.)	43 3/4 (1111 mm)
Width - Crated (in.)	120 (3048 mm)
Depth - Crated (in.)	47 (1194 mm)

* Rating @ +25°F evaporator, 90°F ambient

Figures in parentheses reflect metric equivalents rounded to the nearest whole unit.



Equipped with one NEMA-5-15P Plug
(varies by country)

Model Plan Views

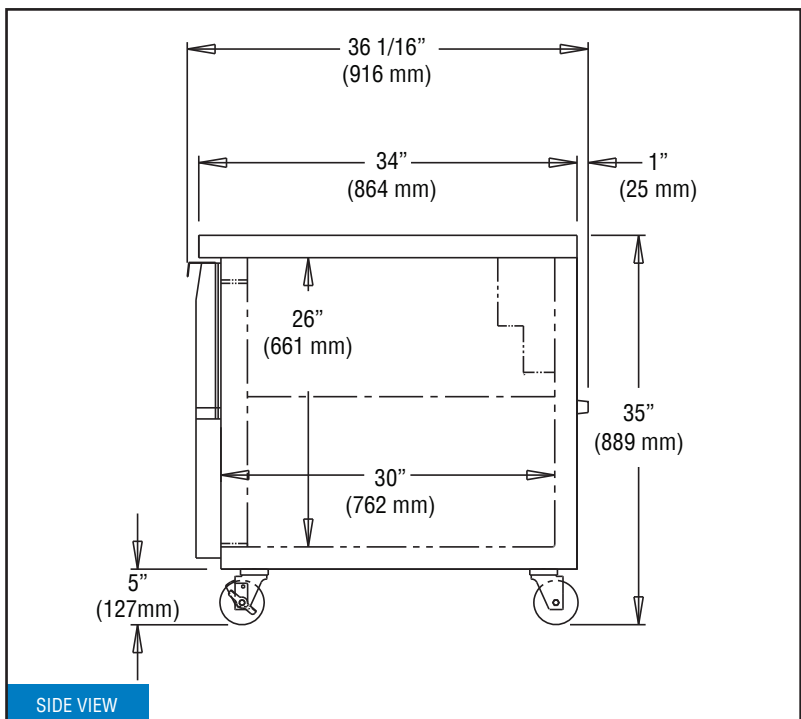
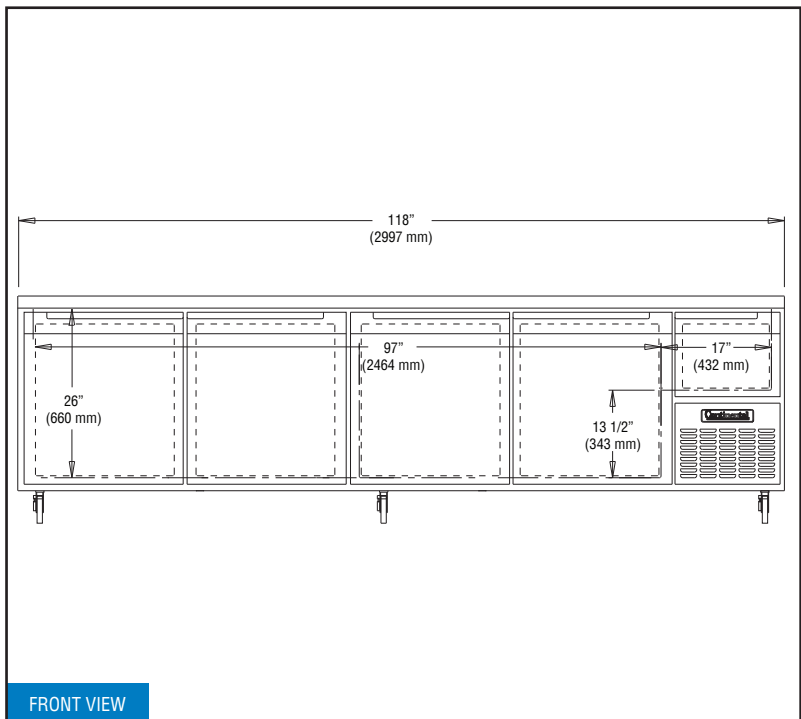

Continental

Refrigerator

Toll-Free: 800-523-7138
Phone: 215-244-1400
Fax: 215-244-9579

539 Dunkserry Road
Bensalem, PA 19020
www.continentalrefrigerator.com

Due to our continued efforts in developing innovative products, specifications subject to change without notice.



MADE IN THE U.S.A.

© Copyright 2015, Continental Refrigerator.
A Division of National Refrigeration & Air Conditioning Products, Inc.