



Cooking Performance Group FEC200EK Double Deck Standard Depth Full Size Convection Oven - 240V, 3 Phase, 22 kW

#351FEC200EK

FEATURES

- Double stack design includes 2 ovens for optimal space efficiency; stacking kit included
- Each oven features full size cavity that houses 3 adjustable wire racks
- Temperature range from 150 to 500 degrees Fahrenheit per oven
- Independent glass doors; stainless steel exterior; porcelain interior floors and sides
- 240V, 3 Phase, 22 kW

TECHNICAL DATA

Width	38 Inches
Depth	41 1/2 Inches
Height	63 1/2 Inches
Interior Width	29 Inches
Interior Depth	20 Inches
Interior Height	22 1/4 Inches
Amps	28 Amps
Hertz	60 Hertz
Phase	3 Phase
Voltage	240 Volts
Wattage	22 Kilowatts
Control Type	Dial
Door Type	Glass
Installation Type	Freestanding
Maximum Temperature	500 Degrees F
Number of Chambers	2



CERTIFICATIONS

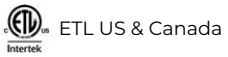

TECHNICAL DATA

Number of Decks	Double
Number of Doors	4 Doors
Number of Racks	6
Oven Interior Style	Standard Depth
Plug Type	Hardwire
Power Type	Electric
Size	Full Size
Temperature Range	150 - 500 Degrees F

Plan View

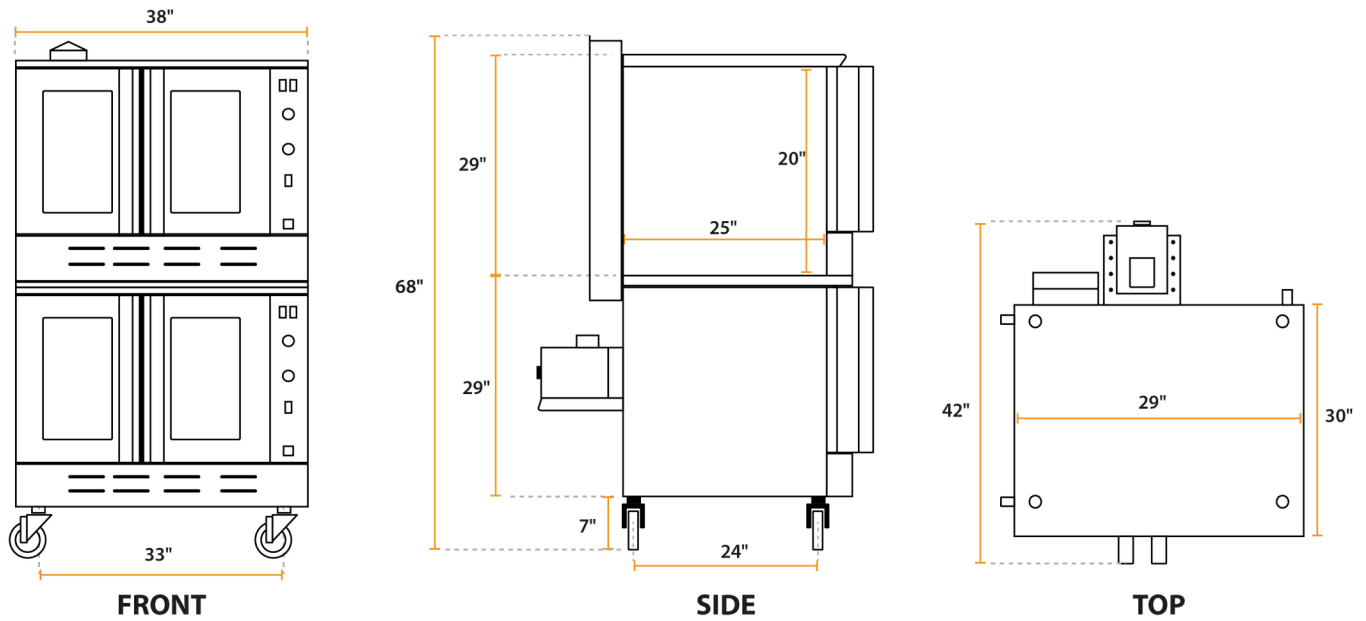

Notes & Details

Perfect for virtually all cooking and baking applications, this Cooking Performance Group FEC200EK double deck full size electric convection oven is a valuable asset to any commercial kitchen. This unit offers 2 full size oven chambers that each comes with 3 adjustable wire racks, and with 11 sets of slides along the interior side walls you can easily adjust the position to accommodate different product sizes and get optimal airflow.

The 11 kW heater in each oven lets it operate at temperatures ranging from 150 to 500 degrees Fahrenheit, and separate thermostats let you set each chamber independently. Each oven chamber also comes with a 2-speed fan that lets you switch between high and low speeds to accommodate many different types of foods, and they also feature "cook" and "cool" modes too.

A 60 minute timer on each oven helps you keep track of foods' progress while you multi-task in the prep or storage areas of your kitchen. Each chamber is also outfitted with 2 independent glass doors, which let you check on dishes without releasing hot air and reducing the chamber temperature. Just flip on the light controlled on the exterior control panel of each oven to see what's cooking! The exterior is built with stainless steel to offer maximum durability, while the interior floors and sides of the oven chambers porcelain to make cleaning fast and easy. This oven package requires a 240V, 3 phase electrical connection and must be hard-wired, a cord and plug are not included.

 **WARNING:** This product can expose you to chemicals including lead, which are known to the State of California to cause cancer, birth defects, or other reproductive harm. For more information, go to www.p65warnings.ca.gov.