

PIZZA PREPARATION TABLE

Model: PA93N-D

Natural Refrigerant R-290 Model

93" Pizza Preparation Refrigerator with Drawers and Half Door

Heavy gauge #300 series stainless steel top, stainless steel front and end panels, aluminum interior.



Options and Accessories

(upcharge and lead times may apply)

Stainless steel interior	Vision panel lids
Stainless steel back	Door/drawer locks
Overshelves (single or double)	Adjustable legs
Condensing unit on left (standard on right)	Front breathing
Drawer in lieu of half door above the condensing unit*	Special electrical requirements (<i>consult factory</i>)
Wire rod garnish rack	

*Drawer section above condensing unit holds (1) 12 x 20 x 6 pan
Consult factory for other model configurations, options and accessories.

Project Name:

Model Specified:

Location:

Item No:

Quantity:

AIA #:

SIS #:

Standard Model Features

REFRIGERATION SYSTEM

Performance-rated refrigeration system

Natural, environmentally-safe, high-efficiency R-290 refrigerant¹

Unique forced air design utilizes fans (approx. every 12") across the entire back of unit for even distribution of cold

Automatic, hot gas condensate evaporator

Non-corrosive, plasticized fin evaporator coil

Easily serviceable, slide-out condensing unit

Expansion valve system

CABINET ARCHITECTURE

2" non-CFC polyurethane foam insulation

Smooth, polished chrome door/drawer handles

Spring loaded, self closing door (above condensing unit)

Magnetic snap-in door/drawer gaskets

Stainless steel roll-out drawers

19" deep, full length nylon cutting board

Insulated lids (with heavy-duty hinge pins)

(10) pan top divider bars*

5" casters

* Pans supplied by others

MODEL FEATURES

Electronic controller w/digital display & hi-low alarm

Ergonomically-friendly raised angle rail

Electronic control, off-cycle defrost

Refrigerated section w/door above the condensing unit

Field rehingeable door (above condensing unit)

¹ R-290 refrigerant meets all federal and state regulatory requirements.

NOTE: Models come standard with a door above the condensing unit. A drawer above the condensing unit is an option.

Continental[®]
Refrigerator

Toll-Free: 800-523-7138
Phone: 215-244-1400
Fax: 215-244-9579

539 Dunksferry Road
Bensalem, PA 19020
www.continentalrefrigerator.com

APPROVAL:

Model Specifications

DIMENSIONAL DATA

Net Capacity (cu. ft.)	32 (906 cu l)
Width, Overall (in.)	93 (2362 mm)
Depth, Overall (in.) (incl. cutting board & bumpers)	38 1/2 (972 mm)
Height, Overall (in.) (incl. 5" casters)	39 (989 mm)
Depth, Cutting Board (in.)	19 (483 mm)
No. of Drawers	6
No. of Half Doors	1
Interior Height (in.) (above condenser)	12 1/2 (318 mm)

PAN TOP

Divider Bars (supplied with model)	(10) CM1-0111
Pan Capacity (pans supplied by others)	(12) 1/3

REFRIGERANT DATA

Condensing Unit Size (H.P.)	1/2
Capacity (BTU/Hr)*	5260

* Rating @ +25°F evaporator, 90°F ambient

ELECTRICAL DATA

Voltage (int'l)	115/60/1 (220/50/1)
Total Amps (int'l)	8.6 (6.6)
10 ft. Cord/Plug [attached] (int'l)	Yes (No)

SHIPPING DATA

Weight (lbs.)	802 (364 kg)
Height - Crated (in.)	43 3/4 (1111 mm)
Width - Crated (in.)	95 (2413 mm)
Depth - Crated (in.)	47 (1194 mm)

DRAWER PAN CONFIGURATIONS

Two Tier: (2) 12 x 20 x 6 pans per drawer

Figures in parentheses reflect metric equivalents rounded to the nearest whole unit.



Equipped with one NEMA-5-15P Plug
(varies by country)

Continental
Refrigerator

Toll-Free: 800-523-7138
Phone: 215-244-1400
Fax: 215-244-9579

539 Dunksferry Road
Bensalem, PA 19020
www.continentalrefrigerator.com

Due to our continued efforts in developing innovative products, specifications subject to change without notice.



MADE IN THE U.S.A.

© Copyright 2020. Continental Refrigerator.
A Division of National Refrigeration & Air Conditioning Products, Inc.

Model Plan Views

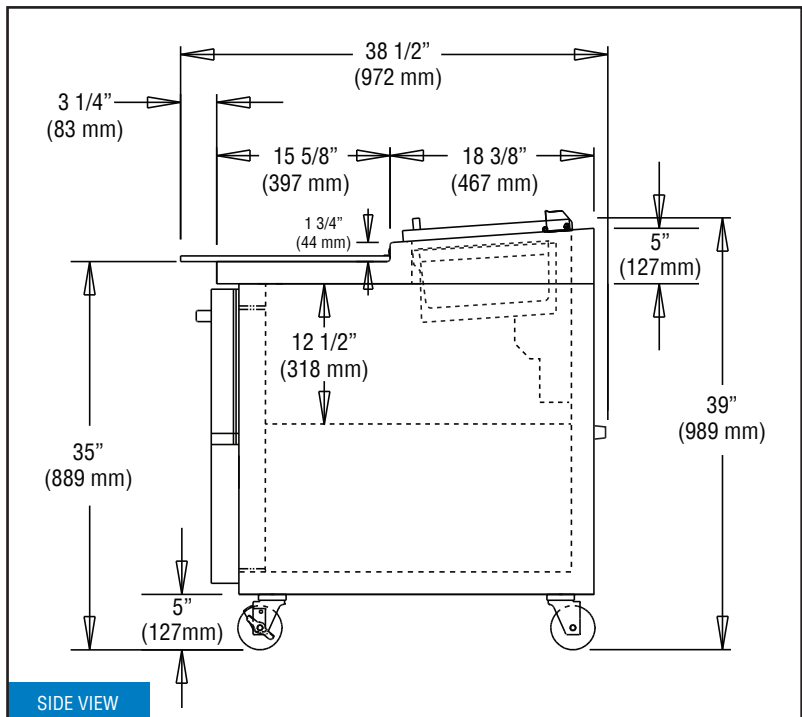
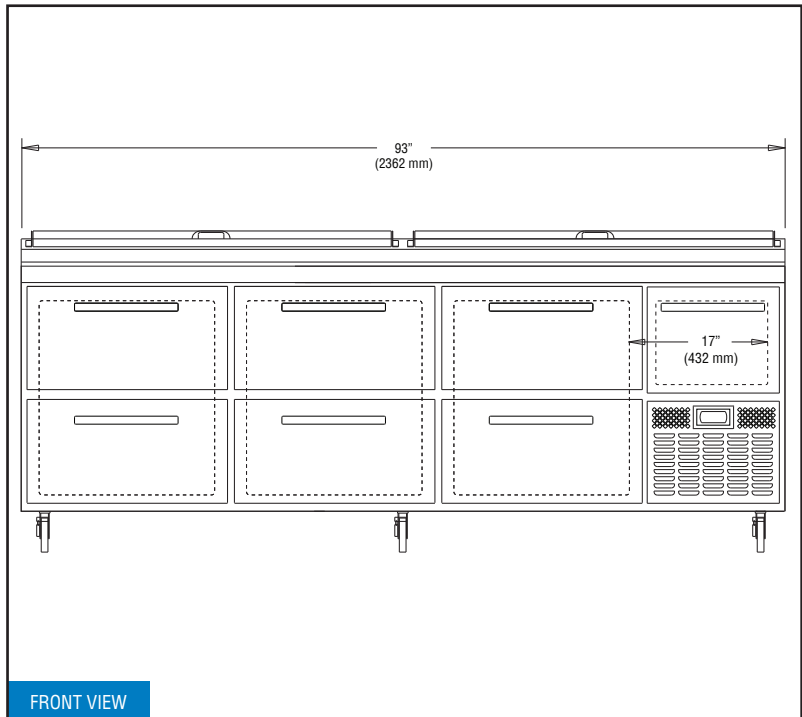

IMPORTANT NOTE: If the cabinet is located directly against a wall, a minimum clearance of 3" is required on sides, front and rear.