

PIZZA PREPARATION TABLE

Model: CPA93-D

93" Pizza Preparation Refrigerator with Drawers and Half Door

Heavy gauge #300 Series stainless steel top, stainless steel front and end panels, galvanized steel rear and grill and aluminum interior.
Certified under NSF-7 to maintain temperatures in 86°F ambient and designed to maintain NSF-7 temperatures in 100°F ambient.



Options and Accessories

(upcharge and lead times may apply)

Stainless steel interior	Wire rod garnish rack
Stainless steel back	Vision panel lid
Doors in lieu of drawers	Door/drawer locks
Drawer in lieu of half door above the condensing unit*	Adjustable legs
Overshelves (single or double)	Front breathing
Condensing unit left or right	Special electrical requirements (consult factory)
Automatic, electric condensate evaporator	

*Drawer section above condensing unit holds (1) 12 x 20 x 6 pan

Project Name:

Model Specified:

Location:

Item No:

Quantity:

AIA #:

SIS #:

Standard Model Features

REFRIGERATION SYSTEM

Performance-rated refrigeration system

Environmentally-safe R-134a refrigerant

Unique forced air design utilizes fans (approx. every 12") across the entire back of unit for even distribution of cold

Automatic, energy saving, non-electric condensate evaporator

Non-corrosive, plasticized fin evaporator coil

Easily serviceable, slide-out condensing unit

CABINET ARCHITECTURE

2" non-CFC polyurethane foam insulation

Spring loaded, self closing door (over condensing unit)

Magnetic snap-in door/drawer gaskets

Stainless steel roll-out drawers

19" deep, full length nylon cutting board

Refrigerated section with door above the condensing unit

Insulated lids

5" casters

MODEL FEATURES

Electronic controller w/digital display & hi-low alarm

Ergonomically-friendly raised angle rail

Expansion valve for quick recovery

Built-in, off cycle defrost timer

Field rehingeable door (over condensing unit)

NOTE: CPA-D models come standard with a door over the condensing unit. A drawer over the condensing unit is an option.

Continental
Refrigerator

Toll-Free: 800-523-7138
 Phone: 215-244-1400
 Fax: 215-244-9579

539 Dunksferry Road
 Bensalem, PA 19020
www.continentalrefrigerator.com

APPROVAL:

Model Specifications

DIMENSIONAL DATA

Net Capacity (cu. ft.)	32 (906 cu l)
Width, Overall (in.)	93 (2362 mm)
Depth, Overall (in.) (incl. handles & bumpers)	36 7/8 (937 mm)
Height, Overall (in.) (incl. 5" casters)	39 7/16 (1002 mm)
Depth, Cutting Board (in.)	19 (483 mm)
Pan Capacity (pans supplied by others)	(12) 1/3
No. of Drawers	6
No. of Half Doors	1
Interior Height (in.) (above condenser)	12 1/2 (318 mm)

REFRIGERANT DATA

Condensing Unit Size (H.P.)	1/2
Capacity (BTU/Hr)*	5260

ELECTRICAL DATA

Voltage (int'l)	115/60/1 (220/50/1)
Fans	6
Total Amps (int'l)	14.4 (9.1)
10 ft. Cord/Plug [attached] (int'l)	Yes (No)

SHIPPING DATA

Weight (lbs.)	605 (274 kg)
Height - Crated (in.)	43 3/4 (1111 mm)
Width - Crated (in.)	95 (2413 mm)
Depth - Crated (in.)	47 (1194 mm)

DRAWER PAN CONFIGURATIONS

Two Tier: (2) 12 x 20 x 6 pans per drawer

Three Tier: (1) 12 x 20 x 4 pan per drawer (top)
and (2) 12 x 20 x 4 pans per drawer (center & bottom)

* Rating @ +25°F evaporator, 90°F ambient

Figures in parentheses reflect metric equivalents rounded to the nearest whole unit.



Equipped with one NEMA-5-15P Plug
(varies by country)

Model Plan Views

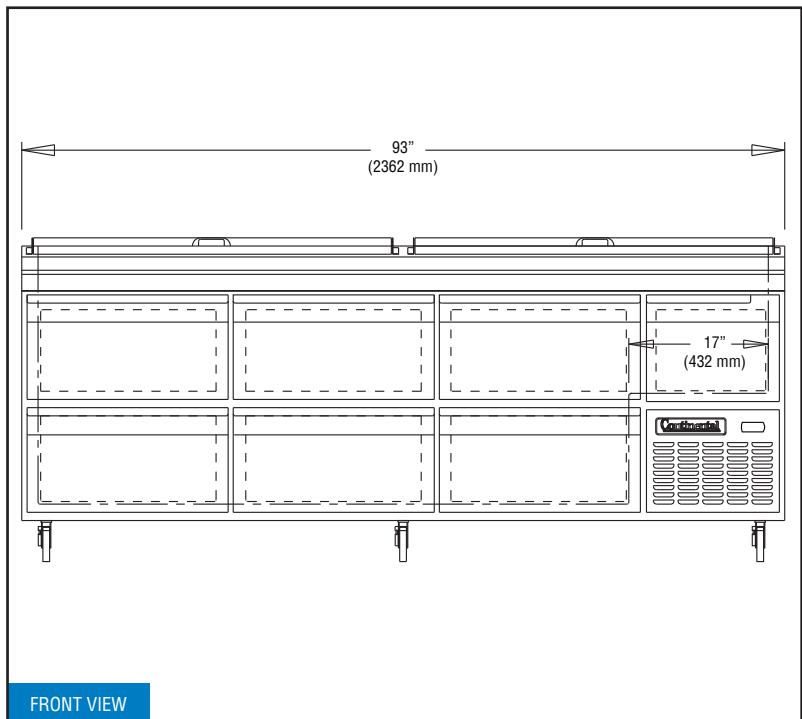

FRONT VIEW

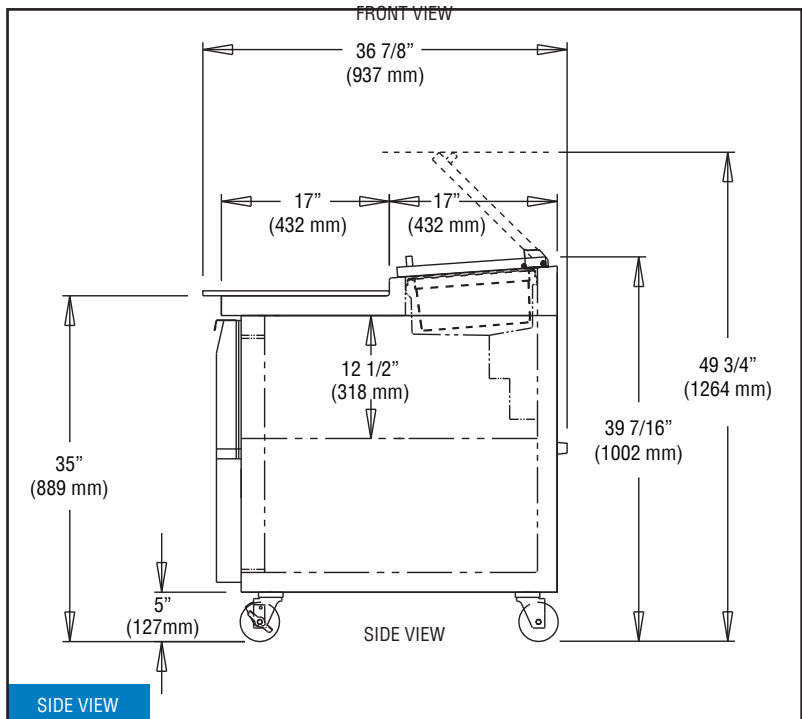

SIDE VIEW

IMPORTANT NOTE: If the cabinet is located directly against a wall, a minimum clearance of 3" is required on sides, front and rear.

Continental
Refrigerator

Toll-Free: 800-523-7138
Phone: 215-244-1400
Fax: 215-244-9579

539 Dunkserry Road
Bensalem, PA 19020
www.continentalrefrigerator.com

Due to our continued efforts in developing innovative products, specifications subject to change without notice.



MADE IN THE U.S.A.

© Copyright 2017. Continental Refrigerator.
A Division of National Refrigeration & Air Conditioning Products, Inc.