

# 16 GAUGE STAINLESS STEEL TWO COMPARTMENT SINKS WITH TWO DRAINBOARDS

ITEM #: \_\_\_\_\_ QUANTITY: \_\_\_\_\_

PROJECT: \_\_\_\_\_

APPROVAL: \_\_\_\_\_

DATE: \_\_\_\_\_



## FEATURES

- Made of high-quality 16 gauge, type 304 stainless steel
- Galvanized 1 $\frac{5}{8}$ " steel legs with sockets
- Adjustable bullet feet for added stability
- Faucet holes pre-punched on 8" centers (faucet sold separately)
- 3 $\frac{1}{2}$ " IPS drain connection
- Rolled edge contains splashes and overflow



## SPECIFICATIONS

ITEM	LENGTH	DEPTH	HEIGHT (Total)	HEIGHT (Work)	BOWL DEPTH	BOWL L to R	BOWL F to B	NUMBER OF DRAINBOARDS	SIDE	NET WEIGHT
600S217172G	72"	22 $\frac{13}{16}$ "	44 $\frac{3}{4}$ "	36 $\frac{1}{2}$ "	12"	17"	17"	2	Both	76.5 LB.



04/2019

# 16 GAUGE STAINLESS STEEL TWO COMPARTMENT SINKS WITH TWO DRAINBOARDS



### TOP

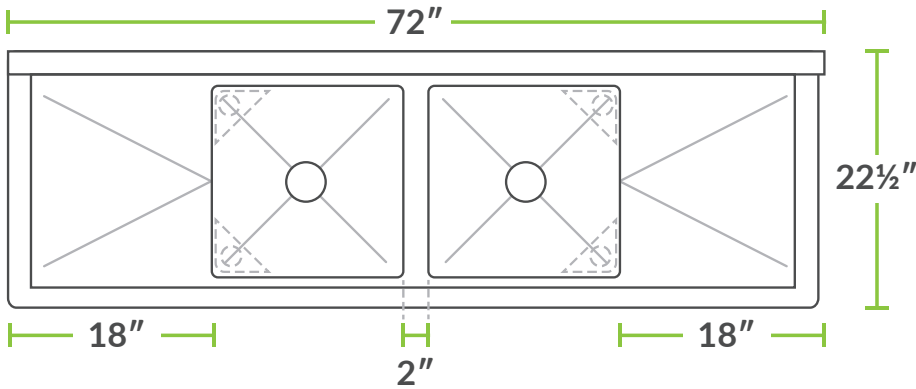

### BOWL

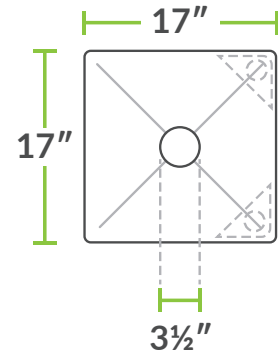

### FRONT

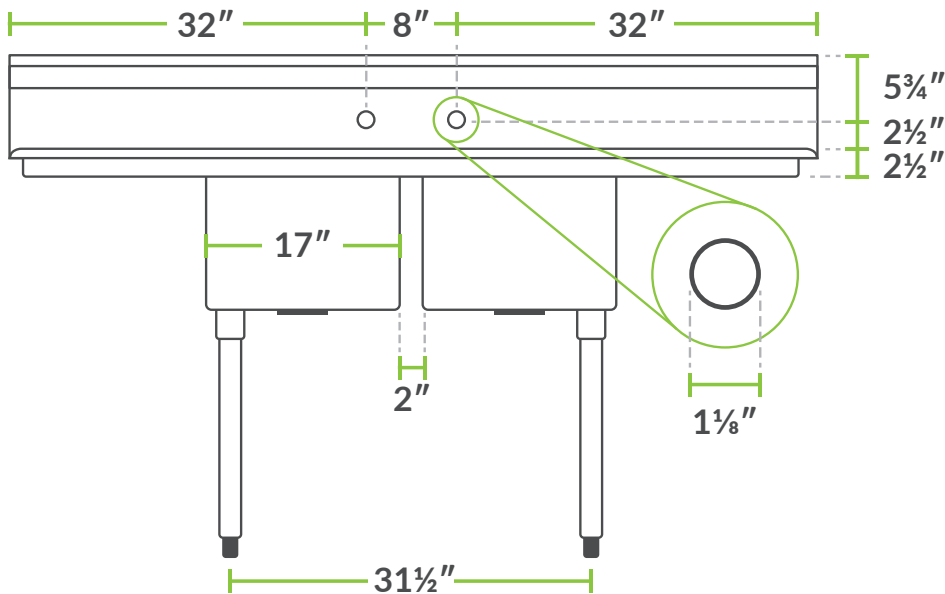

### SIDE

