



CNVX-14E

CNVX-14E

Single or Double Electric Convection Oven
Also designed to stack under
BCX-14E or BX-14E Combi Ovens

Refer to BCX-14E and BX-14E specification sheets for information on the combi ovens.



Shown stacked under Blodgett BCX-14E
Combination Oven-Steamer

Project _____

Item No. _____

Quantity _____

All data is shown per oven section, unless otherwise indicated.

Refer to operator manual specification chart for listed model names.

EXTERIOR CONSTRUCTION

- Stainless steel top, front, sides and back
- Dual pane tempered viewing window with hinged inner glass for easy cleaning
- Door mounted condensate trough
- Top and bottom mount, easily adjustable door hinges
- Pivot out user interface panel for service access

INTERIOR CONSTRUCTION

- Fully welded stainless steel frame
- Fully insulated cooking chamber
- Fixed drain bottom center of cavity
- Easily removable stainless steel side rails
- Coved corner liner for ease of cleaning

OPERATION

- Standard control with thermostat range of 140F to 500F
- Multiple speed reversing fan for even bake
- Dual stage door latch
- Integral door switch

CAPACITY

- Fourteen 12" x 20" x 2-1/2" deep pans at 3-1/4" spacing
- Seven 18" x 26" deep pans at 3-1/4" spacing

STANDARD FEATURES

- Five (5) stainless steel wire shelves per section (capacity for 7)
- Hinged pressure panel for cleanability
- Halogen lights for superior cavity illumination
- Retractable hose reel (excluding top sections)
- Stacking kit and casters for double stack ovens
- Pressure spray bottle for oven cleaning
- 4" core temperature probe
- Floor stand with rack supports
- Start-up inspection service by factory authorized service agent
- One year parts and labor oven warranty*

* For all international markets, contact your local distributor.



Intertek

BLODGETT OVEN COMPANY

www.blodgett.com

44 Lakeside Avenue, Burlington, VT 05401

Phone: (802) 658-6600 • Fax: (802) 864-0183

OPTIONS AND ACCESSORIES

(AT ADDITIONAL CHARGE)

■ Legs

- 6" (152.4mm) adjustable legs
- 6" (152.4mm) seismic legs
- 25" (635mm) adjustable legs
- Stand mount casters

■ Controls

- MenuSelect control can hold multi-stage programming for up to 99 products, includes Cook & Hold, core probe cooking and USB port
- Touchscreen control allows cooking with timer and core probe simultaneously. Includes shelf timing, cooking compensation and multi-shelf recipes. Holds up to 255 recipes.
- Additional 4" core temperature probe
- 415/240VAC, 3 phase
- Additional stainless steel wire shelves
- Chicken roasting rack
- Extended warranty



CNVX-14E



APPROVAL/STAMP

DIMENSIONS ARE IN INCHES (MM)

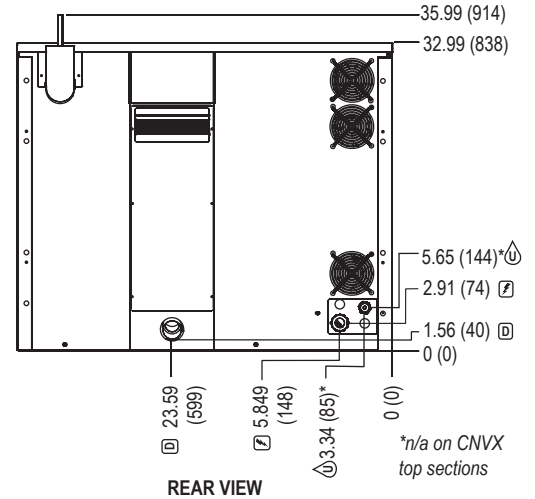
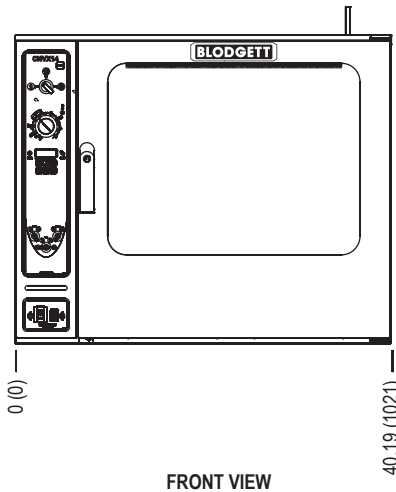
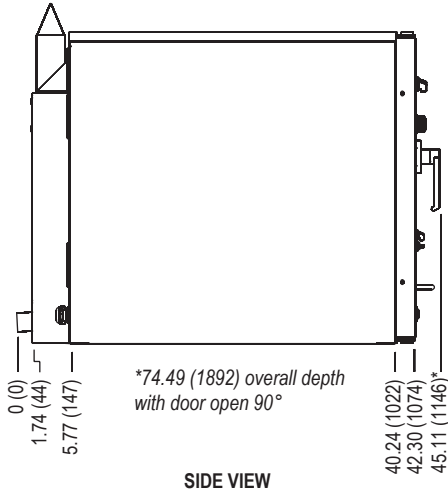

SHORT FORM SPECIFICATIONS: Provide Blodgett Combi model CNVX-14E single, electric convection oven. Unit shall have the ability to cook with hot air at an operating range 140F to 500F, and low temperature cooking and holding. Oven capacity to accept 7ea 18x26 bake pans or 14ea 12x20x2.5" full size steam table pans with 3-1/4" spacing. Front access service user interface control panel and service diagnosis system. Unit shall be constructed with a fully welded stainless steel frame. Cooking chamber shall be constructed with 304 series with bright-annealed stainless steel finish and coved corners. Retractable hose reel (excluding top sections) to include front water shut off valve. Unit shall include a four speed, bi-directional fan. Dual pane thermal glass window with 180 degree door swing, two-step safety door-latch with adjustable door hinges, door mounted drip pan. Unit to include a detachable 4" core temperature probe and halogen lights. Where applicable, quantities in this spec are doubled for stacked units. Unit can also stack with Blodgett model BCX-14E or BX-14E combination oven-steamers. A start-up inspection service will be performed by our factory-authorized agent at no cost to the operator. One-year parts and labor warranty, standard.

DIMENSIONS:

Floor space: 42.30" x 40.19" (1074 x 1021mm)
Unit Height:
 Single 35.99" (914mm)
 Double 68.98" (1752mm)

Additional Height:

6" adjustable legs 6.88" - 8" (174.6-203.2mm)
 6" adjustable seismic legs 6.63" - 8" (168.3-203.2mm)
 25" adjustable legs 25.25" - 26.38" (641.4-670mm)
 Low profile caster 4" (101.6mm)
 Stand w/rack supports 22.5" - 23.63" (571.5-600.1mm)
 Stand w/rack supports on casters 22.63" (574.7mm)

OVEN CLEARANCES:

Right Side 2" (50.8mm)
 Left Side 2" (50.8mm)
 Rear 3" (76.2mm)

MINIMUM ENTRY CLEARANCE:

Uncrated 33" (838mm)
 Crated 42" (1066.8mm)

POWER SUPPLY (per section):

208VAC 19.0 kW 3 phase (53 amp)
 240VAC 19.0 kW 3 phase (46 amp)
 480VAC 19.0 kW 3 phase (23 amp)

WATER SUPPLY & DRAIN:

Water Supply: 3/4" hose cold water connection (n/a on CNVX-14E top sections)
Drain:
 2" drain connection Maximum drain temperature 140°F (60°C)
 Appliance is to be installed with backflow protection in accordance with Federal, State or Local codes. (n/a on CNVX-14E top sections)

SHIPPING INFORMATION:

Approx. Weight:
 Single section 595 lbs. (270 kg)
 Double stack* 1220 lbs. (553 kg)
 Stand w/guides 140 lbs. (64 kg)
 *Use single section weight when stacking with BCX-14E or BX-14E

Crate size (per section):

44.5" H x 42" W x 54.5" D (1130 x 1067 x 1384mm)

NOTE: The company reserves the right to make substitutions of components without prior notice

BLODGETT OVEN COMPANY

www.blodgett.com • 44 Lakeside Avenue, Burlington, VT 05401 • Phone: (802) 658-6600 • Fax: (802) 864-0183