



## BCH-G

Gas Cabinet Based Braising Pan with Heavy Duty Hydraulic Tilt



### OPTIONS AND ACCESSORIES

(AT ADDITIONAL CHARGE)

- **Faucets**
  - Single pantry faucet with swing spout
  - Double pantry faucet with swing spout
- **Etched markings**
  - Gallons
  - Litres
- Steam pan insert
- Pan carrier
- Correctional package

Project \_\_\_\_\_

Item No. \_\_\_\_\_

Quantity \_\_\_\_\_

- Model BCH-30G (30 gallon gas braising pan with hydraulic tilt)
- Model BCH-40G (40 gallon gas braising pan with hydraulic tilt)

### CONSTRUCTION

- #4 Satin finish 10 gauge stainless steel pan with polished interior, front hinged for easy tilting
- Coved corners
- 10 gauge type 304 stainless pan with 3/4" triple-ply aluminum core cooking surface
- Cabinet base of heavy duty welded angle frame with bullet feet on front legs and flanged adjustable feet on back legs
- 304 stainless steel removable side panels and two front doors on cabinet base

### OPERATION

- Controls mounted in cabinet base
- Electronic ignition
- Power switch
- Thermostat
- Cook indicator light
- High limit thermostat located on pan bottom
- Tilt switch
- Tilt safety switch
- 100-450°F (38-232°C) temperature range
- Gas supply to burner shuts off automatically when pan is tilted

### STANDARD FEATURES

- 1/2 HP hydraulic tilting system for smooth and precise tilting action
- Spring assist hinged stainless steel cover with handle
- Condensate guide
- Removable pour strainer
- Manual control
- 115VAC, 1 phase, 60 Hz
- One year parts and labor warranty\*

\* For all international markets, contact your local distributor.



BCH-G BRAISING PAN WITH HYDRAULIC TILT

**BLODGETT COMBI**

www.blodgett.com

44 Lakeside Avenue, Burlington, VT 05401 • Phone: (802) 658-6600 • Fax: (802) 864-0183



# BCH-G GAS BRAISING PAN W/HYDRAULIC TILT

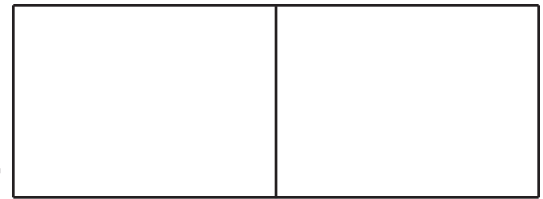

APPROVAL/STAMP

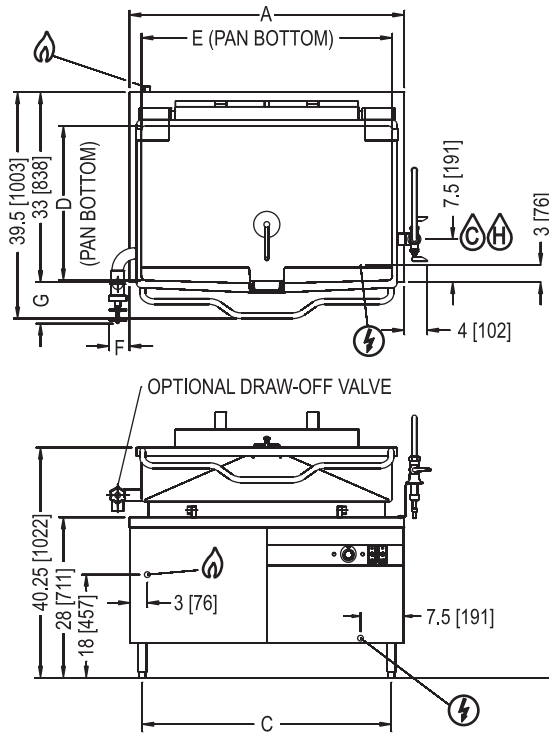

DIMENSIONS ARE IN INCHES [MM]



**REAR FLANGED FOOT DETAIL**  
 4 EQUALLY SPACED  
 Ø7/16" [11mm] HOLES  
 ON 3 [76] B.C.

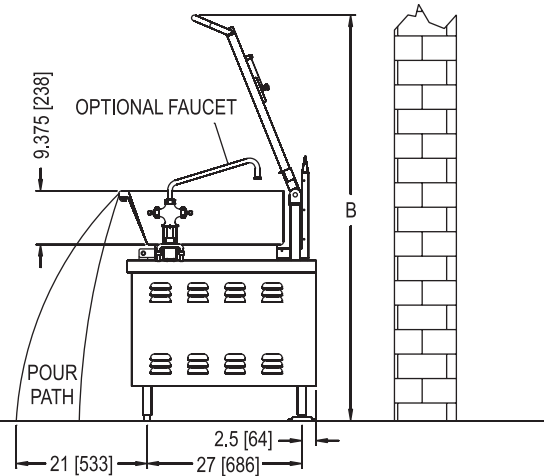

MODEL	A	B	C	D	E
BCH-30G	36[914]	70.88[1800]	30[762]	23.5[597]	33.75[857]
BCH-40G	48[1219]	70.88[1800]	42[1067]	23[584]	43.75[1111]

VALVE DIAMETER	F	G
2"	3.6[92]	7.3[186]
3"	5.5[140]	13.1[333]

**SHORT FORM SPECIFICATIONS**

Provide Blodgett model BCH-30G, 30 gallon (114 litre) or BCH-40G (152 litre) gas cabinet base braising pan with heavy duty hydraulic tilt. The unit shall have a one-piece covered corner, 10 gauge type 304 stainless pan with 3/4" triple-ply aluminum core cooking surface. The burners shall shut off automatically when the pan is tilted. Cooking surface shall be 5/8" thick stainless steel clad plate ensuring even heat distribution over entire cooking surface. Unit shall be mounted on a heavy duty welded angle construction frame with front legs fitted with adjustable bullet feet and rear legs fitted with flange adjustable feet for securing to the floor. The cabinet base shall be enclosed with #4 finish type 304 stainless steel with removable side panels and two stainless steel front cabinet doors. Tilting is controlled by a 1/2 HP hydraulic tilting system for smooth and precise tilting action. The controls shall be mounted in the cabinet base and shall include a power switch, tilt switch, thermostat with range of 100-450°F (38-232°C), a cook indicator light and electronic ignition. The hi limit thermostat is located on the pan bottom. Unit shall include spring assisted hinged stainless steel cover, with handle, condensate guide and removable pour strainer. Provide options and accessories as indicated.

**MAXIMUM INPUT:**

BCH-30G 80,000 BTU  
 BCH-40G 100,000 BTU

**GAS SUPPLY:**

3/4" IPS supply line required. A gas shut-off valve must be installed in supply piping convenient and adjacent to unit

**Minimum Inlet Pressure:**

Natural 6.0" W.C. static to unit  
 Propane 11.0" W.C. static to unit

**WATER CONNECTION**

Hot and Cold water 3/8" O.D. tubing to optional faucet

**NOTE:** The company reserves the right to make substitutions of components without prior notice.

**ELECTRICAL CONNECTION:**

Unless otherwise specified, field wire electrical connection to be 120 VAC, 1 phase, 60 Hz with grounding wire

**PRODUCT CLEARANCE**

Left side 3" (76 mm)  
 Right side 3" (76 mm)  
 Rear 6" (152mm)

**SHIPPING INFORMATION:**

**Approx. Weight:**

BCH-30G 700 lbs. (317 kg)  
 BCH-40G 875 lbs. (397 kg)

**BLODGETT COMBI**

www.blodgett.com

44 Lakeside Avenue, Burlington, VT 05401 • Phone: (802) 658-6600 • Fax: (802) 864-0183