



SSWD Series Worktop Refrigerator

MODEL #178SSWD260RC

CABINET CONSTRUCTION

Heavy-duty construction includes a 304 type stainless steel interior and a 430 type stainless steel exterior, resulting in strength, durability, and an attractive, sleek appearance.

Countertop features built-in 3½" backsplash for wall protection and easy cleaning. Working height of 35¼" sits flush to most counters.

Foamed-in-place CFC- and HCFC-free polyurethane insulation enhances the structural strength of the cabinet and helps increase energy efficiency.

Four easy sliding drawers help streamline and maximize your kitchen's workflow.

REFRIGERATION SYSTEM

Environmentally safe R290 refrigerant. Side-mounted condensing unit positioned for easy maintenance..

STORAGE

12 divider bars are included that can hold full size or fractional pans.

MODEL FEATURES

Backsplash prevents tools and food from falling behind the unit.

Copper evaporator coil eliminates the potential of corrosion.

Interior wall-mounted thermometer for easy temperature monitoring.

Preprogrammed digital controller features auto-defrost function.

Deeper style cabinet allows for more storage room.

PROJECT: _____

MODEL: _____ SERIAL#: _____

ITEM #: _____ QUANTITY: _____

APPROVAL: _____ DATE: _____

SSWD SERIES – WORKTOP REFRIGERATOR

Increase cold food prep storage and expand the workspace in your kitchen

SPECIAL FEATURES

- Side mounted compressor allows for extra storage depth
- 3½" backsplash protects your wall
- Extra large drawers with 6 divider bars are each capable of holding up to 2 full size food pans in full or fractional configurations
- Strong and sleek 430 type stainless steel exterior and 304 stainless steel interior for maximum corrosion resistance
- Foamed-in-place polyurethane insulation helps maintain food safe temperatures of 33°F - 40°F
- Easy-to-read digital temperature controller with auto defrost function
- Full-length stainless steel handles for increased accessibility
- Eco-friendly R290 hydrocarbon refrigerant
- Casters for easy mobility
- 115V; 1/4 hp



★ Conforms to UL & NSF-7 Standards

WARRANTY

RESIDENTIAL: Avantco assumes no liability for parts or labor coverage for component failure, factory defect or any other damages for units installed in non-commercial foodservice or residential applications.



Parts & Labor



Compressor



TECHNICAL DATA

Dimensions

Exterior Dimensions	60"W x 31½"D x 38"H
Interior Dimensions	39⅞"W x 26¾"D x 22⅞"H
Depth when Open	55⅞" (Door) • 61" (Drawer)
Net Volume	13.1 Cu. Ft.
Net Weight	220 lb.
Gross Weight	265 lb.
Packing Dimensions	62¾"W x 34¼"D x 39"H

Cooling

Temperature Range	33°F - 40°F
Refrigerant	R290/ 85g
Max. Ambient Temperature	90°F
Defrosting	Automatic
Temperature Controller	Digital
Horsepower	1/4
BTU (BTU/hr)	631

Construction

Exterior Material	Type 430 Stainless Steel
Interior Material	Type 304 Stainless Steel
Door Type	(4) Solid Drawers
Insulation Material	Foamed-in-place Polyurethane
Shelves	N/A
Shelf Size	N/A
Shelf Material	Epoxy-coated Steel
Shelf Load Capacity	90 lb.

Electrical

Voltage	115
Amps	4
Hz	60
Phase	1
Plug Type	NEMA 5-15P
Electrical Cord Length	98"

PLAN VIEW

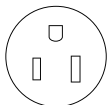
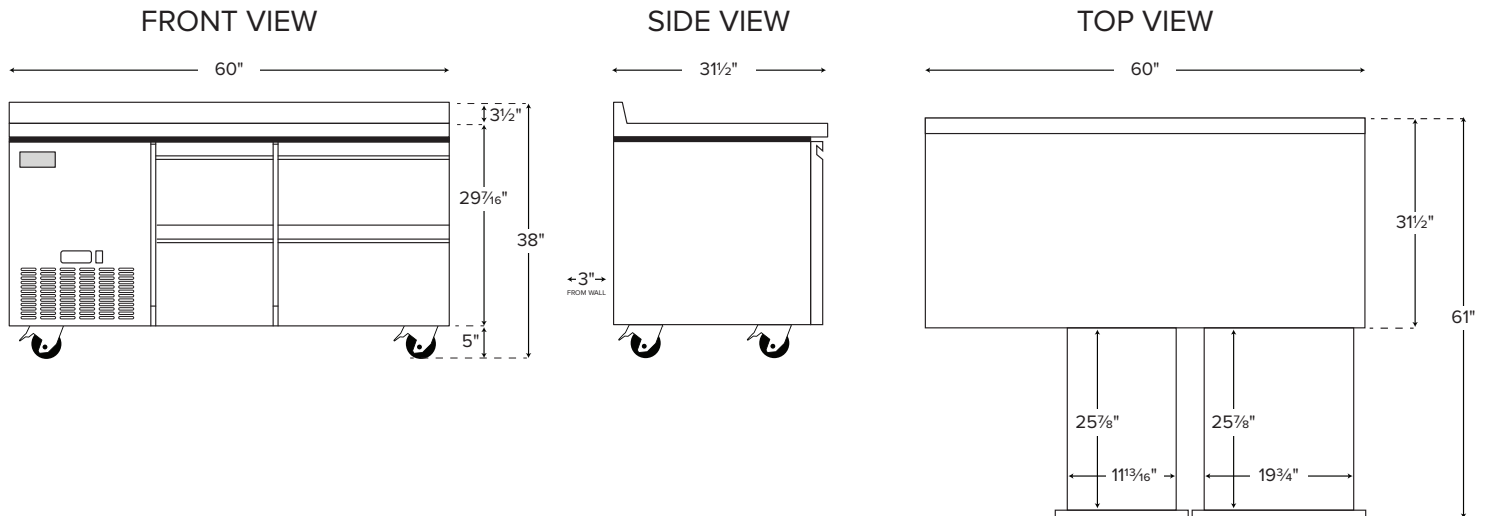

NEMA 5-15P