

## Avantco BCS-28-HC 27 1/2" White Refrigerated Square Countertop Bakery Display Case with LED Lighting

Item #360BCS28HCW



### Technical Data

Width	27 5/8 Inches
Depth	22 3/8 Inches
Height	27 Inches
Amps	2.7 Amps
Hertz	60 Hertz
Phase	1 Phase
Voltage	110 - 120 Volts
Access Type	Doors
Capacity	4.25 cu. ft.
Color	White
Compressor Location	Bottom Mounted
Display Case Type	Refrigerated
Door Style	Sliding
Door Type	Glass
Features	LED Lighting Lighted Interior
Glass Style	Flat
Horsepower	1/4 HP
Installation Type	Countertop
Number of Doors	2 Door
Number of Shelves	2 Shelves
Plug Type	NEMA 5-15P
Refrigerant Type	R-290
Service Type	Full Service
Temperature Range	33 - 40 Degrees F
Total BTU	1261 BTU
Type	Countertop Bakery Cases

### Features

- Bright, cool LED lighting shows off your food products
- Air outlet circulates air against the glass to remove condensation for clear visibility
- Sliding glass doors for easy access without blocking walking areas
- 4.25 cu. ft. capacity with 2 interior chrome-plated shelves to organize baked goods
- Easy-to-use digital controls; uses environmentally-friendly R-290 refrigerant

### Certifications



ETL US



5-15P



ETL Sanitation

## Plan View

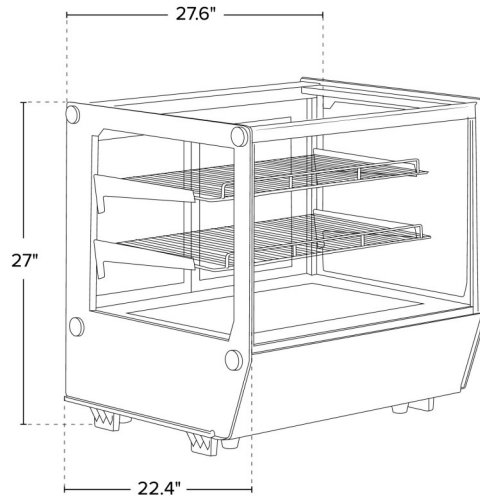

## Notes & Details

Display your signature cakes, pies, and eclairs with ease using this Avantco BCS-28-HC 27 1/2" white refrigerated square countertop bakery display case with LED lighting. This compact countertop unit is made to allow you to place your baked goods in a convenient location where they can merchandise themselves to hungry customers. Whether you are looking for a small bakery case to place on your cafe's counter near your point of sale, or a refrigerated case to set up on your diner's counter where customers can see your dessert selection while they eat, this unit is a great option. You can even use it in your bakery to keep a selection of macarons or fruit tarts on display at eye level!

This bakery display case features bright, cool LED lighting that is designed to show off your chilled baked goods! With a proper display, your bakery items can merchandise themselves and increase impulse sales. The case also has two chrome plated wire interior shelves that you can adjust depending on the items you want to display. In total, this model has a capacity of 4.25 cu. ft.

The flat front glass provides an unobstructed view of your food while the side glass panels and rear glass access doors ensure that customers can see the case's contents from any angle. A specialized air outlet design circulates air against the glass front to reduce the build-up of condensation. Without condensation to get in the way, your customers will always have clear visibility to your tempting desserts!

This model uses eco-friendly R-290 refrigerant to keep the interior temperatures at safe levels between 33-40 degrees Fahrenheit. This specialized refrigerant has an ozone depletion potential (ODP) of 0 and a global warming potential (GWP) of 3, making it an environmentally-responsible choice for your business. It has a 5/16 hp compressor and requires a 110V electrical connection for operation.

**⚠ WARNING:** This product can expose you to chemicals including lead, which are known to the State of California to cause cancer, birth defects, or other reproductive harm. For more information, go to [www.p65warnings.ca.gov](http://www.p65warnings.ca.gov).