



Outperform every day.™

ENGLISH

Operator's Manual



Wedgemaster®

606N

808N

808SG



Thank you for purchasing this Vollrath Food Processing Equipment. Before operating the equipment, read and familiarize yourself with the following operating and safety instructions. **SAVE THESE INSTRUCTIONS FOR FUTURE REFERENCE.** Save the original box and packaging. Use this packaging to ship the equipment if repairs are needed.

SAFETY PRECAUTIONS

To ensure safe operation, read the following statements and understand their meaning. This manual contains safety precautions which are explained below. Please read carefully.

WARNING

Warning is used to indicate the presence of a hazard that *can* cause severe personal injury, death, or substantial property damage if the warning is ignored.

CAUTION

Caution is used to indicate the presence of a hazard that *will* or *can* cause *minor* personal injury or property damage if the caution is ignored.

NOTE

Note is used to notify people of installation, operation, or maintenance information that is important but not hazard-related.

For Your Safety!

These precautions should be followed at all times. Failure to follow these precautions could result in injury to yourself and others or damage the equipment.

To reduce risk of injury or damage to the equipment:

- Check equipment before each use to insure the equipment is clean.
- Check for broken, nicked or dull blades and if found, replace the blade assembly.
- Check to insure that the pusher head sits down completely on the rubber bumpers.
- If necessary, lubricate guide rods using a light coating of mineral oil, Petro Gel, or food grade lubricant. **DO NOT USE COOKING OIL AS IT WILL BECOME STICKY AND MAY PERMANENTLY DAMAGE THE PUSHER HEAD BEARINGS**

FUNCTION AND PURPOSE

Intended for wedging vegetables and fruits.

FEATURES AND CONTROLS

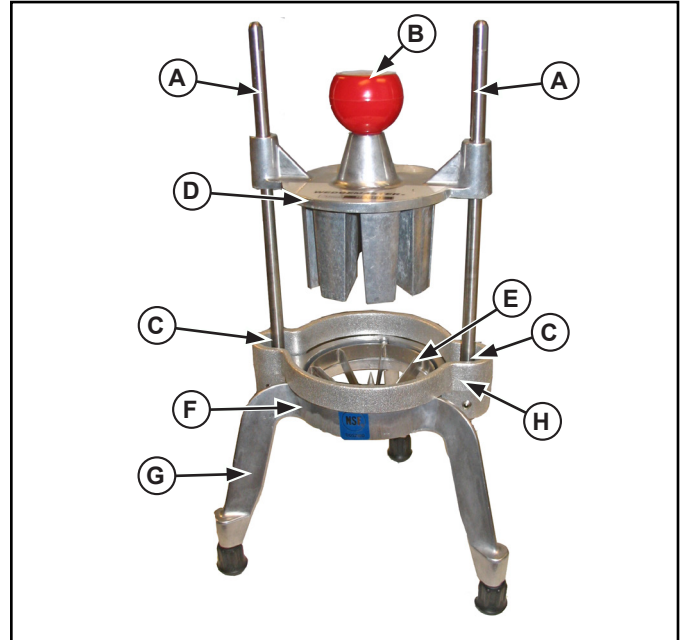

Figure 1. Features and Controls.

- (A) GUIDE RODS. Guides and align the pusher head onto the blade set.
- (B) HANDLE. Used to lower and raise the pusher head.
- (C) BUMPERS. Cushions the stop of the pusher head.
- (D) PUSHER HEAD ASSEMBLY. Made up of the guides and the pusher head block.
- (E) BLADE ASSEMBLY. Houses the blades. Specifically sized to match the corresponding pusher head block.
- (F) BASE ASSEMBLY. Holds guide rods and the blade assembly.
- (G) LEGS. Supports the equipment and holds the blade assembly.
- (H) SAFETY GUARD (some models). Helps keep fingers away from the blade assembly and reduces the spray of juices from food product.

UNPACKING THE EQUIPMENT AND INITIAL SETUP

Carefully remove crating or packaging materials from the equipment. When no longer needed, dispose of all packaging, materials in an environmentally responsible manner.

OPERATION

	WARNING
	Sharp Blade Hazard. Blades are sharp and can cause cuts. To avoid injury from sharp blades, handle with caution.

Prior to first use, it is important to clean the equipment. Wash new blades with warm soapy water and rinse thoroughly to remove the thin protective oil film.

1. Place the equipment on a clean, flat work surface.
2. Before each use, check that the equipment is clean and the blades are in good condition. If loose or broken blades are found, blades must be serviced.
3. Before each use, check for proper blade alignment. Slowly set the pusher head (D) onto the blade assembly (E). See Figure 1. They should slide together with no obstructions. If there are obstructions, verify they are a matching set. Remove the obstruction.
4. Verify that the blade assembly and pusher head assembly are the desired size.
5. Prepare the food product to be processed. For lemons, limes and some other fruit the equipment will work better if the ends are cut off. Remove the stem scar on tomatoes.
6. Lift the handle (B) and place the food on the blade assembly (H) (center spike for wedge blades).
7. Remove hand from the blade assembly (H) area and place that hand on one of the legs (F).
8. Using a strong, quick, downward thrust, force the food product through the blade assembly.
9. Repeat this process until you have prepared enough food product for your daily needs.
10. Clean and lubricate your equipment immediately after each use. See the **CLEANING** section of this manual for more information.

CLEANING

	WARNING
	Sharp Blade Hazard. Blades are sharp and can cause cuts. To avoid injury from sharp blades, handle with caution.

To maintain the appearance and increase the service life, clean your daily.

NOTE:
Food acids will make blades dull and corrode the metal. Always clean this food preparation equipment immediately after every use.

1. Slide the pusher head assembly (D) off the rod guides (A). Figure 1.
2. Remove the safety guard (H) (some models).
3. Remove the screws securing the blade assembly (E).

4. The blade assembly (E) is best cleaned by forcing water under pressure through the blades from the unsharpened side. If necessary, use a nylon bristle cleaning brush to push food particles out from the unsharpened side of the blade assembly (E).
5. Do not put this equipment in a dishwasher or dish machine with soaps, detergents, or other alkaline chemicals that can harm the equipment.
6. Wash the parts in warm soapy water and rinse thoroughly.
7. Allow the parts to air dry.
8. Install the blade assembly (E) so the tabs on the blade assembly slide into the groves of the base assembly (F).
9. Secure the blade assembly (E) to the base assembly (F) using the screws removed earlier.
10. Lubricate the guide rods with mineral oil or Petro Gel after each use. Do not use cooking oil as it will become sticky and may permanently damage the equipment.

PREVENTATIVE MAINTENANCE

1. Clean the equipment after every use.
2. Use for intended purposes only.
3. Change the blades regularly - based on usage.

REPLACING BLADE ASSEMBLY

	WARNING
	Sharp Blade Hazard. Blades are sharp and can cause cuts. To avoid injury from sharp blades, handle with caution.

Wash new blades with warm, soapy water and rinse thoroughly to remove the thin protective oil film. Keep the sharp edge away from you when handling blades.

1. Familiarize yourself with the parts diagram for your equipment.
2. Remove the pusher head assembly (D) by sliding it off the rod guides (A). Figure 1.
3. Raise the bumpers approximately (C) 2" (5.0 cm).
4. Remove the screws securing the blade assembly (E) and discard the old blade assembly and retain the screws.
5. Install the new blade assembly (E) so the tabs slide into the groves of the base assembly (F).
6. Secure new blade assembly to the base using the screws removed earlier.
7. Slide bumpers (C) down guide rods (A) to contact the base (F). Lubricate the guide bar with mineral oil or Petro Gel after each use. Do not use cooking oil as it will become sticky and may permanently damage the equipment.

TROUBLESHOOTING

If the equipment no longer processes food cleanly or without damage to the food product, the blades could be dull and be in need of replacement. Broken, bent, or nicked blades must be replaced.

Problem	It might be caused by	Course of Action
Broken Blade.	Blades were dull.	Pre-score whenever possible to avoid undue shock and stress to blades Replace the blade assembly.

SERVICE AND REPAIR

Please contact Vollrath Technical Service from the list below.

VOLLRATH Technical Service • 1-800-628-0832
• Email: techservicereps@vollrathco.com

When contacting Vollrath Technical Service, please be ready with the item number, model number (if applicable), serial number, and proof of purchase showing the date the equipment was purchased.

SPARE PARTS LIST - WEDGWMMASTER® ~ MODELS 606N, 808N, 808SG

LETTER	PART NUMBER.	DESCRIPTION
A	0304	Red Knob Handle (included with item G)
B	N/A	Aluminum Nipple (included with item G)
C	301	Base Housing & Rod Assembly
D	302	Blade Screw
E	303	Rubber Foot
F	305	"O" Ring
G	316	Head Assembly, Wedge Master, 6-Section
	318	Head Assembly, Wedge Master, 8-Section
	326	Head Assembly, Core Master, 6-Section
	328	Head Assembly, Core Master, 8-Section
H	306	Blade Assembly, Wedge Master, 6-Section
	308	Blade Assembly, Wedge Master, 8-Section
	336	Blade Assembly, Core Master, 6-Section
	338	Blade Assembly, Core Master, 8-Section
Not Shown		Safety Guard

EXPLODED VIEW - WEDGEMASTER® ~ MODELS 606N, 808N, 808SG

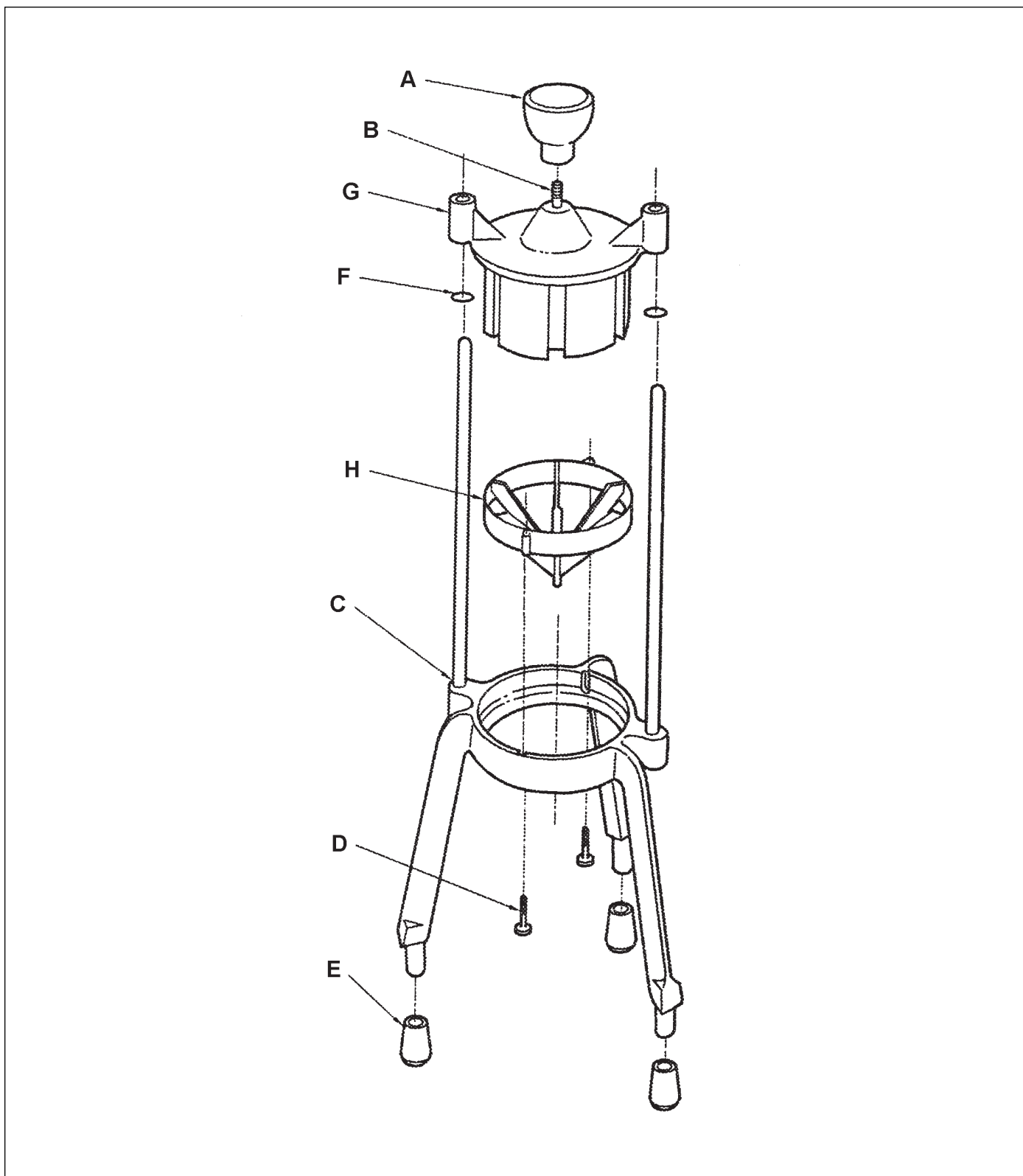

ENGLISH

WARRANTY STATEMENT FOR THE VOLLRATH Co. L.L.C.

This warranty does not apply to products purchased for personal, family or household use, and The Vollrath Company LLC does not offer a written warranty to purchasers for such uses.

The Vollrath Company LLC warrants each of its products listed below against defects in materials and workmanship for the applicable period provided below. All other products manufactured or distributed by The Vollrath Company LLC are warranted against defects in materials and workmanship for a period of one year. In all cases, the warranty runs from the date of the end user's original purchase found on the receipt. Any damages from improper use, abuse, modification or damage resulting from improper packaging during return shipment for warranty repair will not be covered under warranty.

- Vollrath – Redco® products – The warranty period is 2 years
- Replacement parts – The warranty period is 90 days.

For complete warranty information, product registration and new product announcement, visit www.vollrath.com.



www.vollrath.com

The Vollrath Company, L.L.C.
1236 North 18th Street
Sheboygan, WI 53081-3201
U.S.A.

Main Tel: 800.628.0830
Fax: 800.752.5620

Technical Services: 800.628.0832
Service Fax: 920.459.5462

Canada Service: 800.695.8560

© 2014 The Vollrath Company, L.L.C.