

REFRIGERATOR MANUFACTURER
Turbo air
 more durable, efficient, beautiful

4184 E. Conant St.
 Long Beach, CA 90808
 Tel. 310-900-1000
 Fax. 310-900-1077
www.turboairinc.com

Project :
 Model # :
 Item # : Qty :
 Available W/H :
 Approval :

Narrow Back Bars

*Underbar Equipment
 Super Deluxe Series*

**Model : TBB-24-60SG-N
 TBB-24-60SB-N6**



TBB-24-60SG-N



TBB-24-60SB-N6

Easy to Clean Air Filter
 Front Access



≡ FEATURES & BENEFITS ≡

■ **Equipped with easy-to-clean Air Filter**

The accumulation of dust in the condenser causes failures and/or breakdowns in refrigeration. Refrigeration operate normally until they accumulate a certain amount of dust. When they reach over their limit, performance will drop rapidly, resulting in damages and possible disposal of stored goods. This is why all refrigeration manufacturers require the condenser to be cleaned at least once a month for warranty to remain valid. Fortunately for Turbo Air, this process is simplified due to the frontal access air filter device. Users only need to pull out the filter and vacuum lightly to remove the dust. Simply place it back into position when complete.

■ **Hydrocarbon refrigerants (R-290 / R-600a)**

With innovative and eco-friendly technology, Turbo Air brings you hydrocarbon refrigerators designed to meet the new standards of the EPA and DOE in 2017. Hydrocarbon refrigerants do not deplete the ozone layer and have very low contribution to global warming (ODP-0, GWP-3).

■ **Forced air cooling system**

Fast cooling and balanced temperature throughout the cabinet.

■ **Stainless steel countertop and interior**

The exterior of the cabinet is constructed with heavy gauge reinforced stainless steel countertop and wear-resistant black vinyl coated galvanized steel. The interior is stainless steel except galvanized steel top. Turbo Air Back Bar model guarantees the utmost in cleanliness and long product life. It also adds a touch of style to the most refined setting.

■ **Ergonomically designed doors**

Customers' fatigue fades away with easy grip handles and doors that open effortlessly. These features along with self-closing doors make this the ultimate choice in customer convenience.

■ **LED lighting interior**

■ **Double pane glass doors with Low-E glass (SG Models)**

■ **High-density polyurethane insulation**

The entire cabinet structure is foamed-in-place using high density, CFC free polyurethane insulation.

■ **Adjustable, heavy duty, PE (polyethylene) coated wire shelves**

■ **Side mount compressor unit**

With compressors positioned on the side of the unit, our refrigerators can now be serviced without being moved. Our innovative, front breathing feature also allows this model to be highly efficient in narrow spaces.

■ **Refrigerator holds 33°F ~ 38°F for the best in beverage preservation**

† ENERGY STAR rated models



Model	Swing Door	CU./FT.	1/2 Barrels	#of Shelves	HP	AMPS	Crated Weight (lbs.)	L x D* x H† (inches)
TBB-24-60SG-N †	2	16.46	2	4	1/3	2.9	307	611/8 x 241/2 x 353/8
TBB-24-60SB-N6	2	16.46	2	4	1/5	2.0	279	611/8 x 241/2 x 353/8

Model : TBB-24-60SG-N/SB-N6

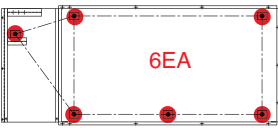
ELECTRICAL DATA		
Voltage		115/60/1
Plug Type		Ⓜ NEMA 5-15P
Full Load Amperes		2.9 (SG) / 2.0 (SB)
Compressor HP		1/3(SG) 1/5(SB)
Refrigerant		R-290(SG) R-600a(SB)
Cord Length (ft.)		9
Lamp (W)		9
DIMENSIONAL DATA		
Capacity	1/2 Barrels	2
	Cubic Feet	16.46
Ext. Length Overall (in.)		61 1/8 (1553mm)
Ext. Depth Overall (in.)*		24 1/2 (623mm)
Ext. Height Overall (in.)†		35 3/8 (900mm)
Net Weight (lbs.)		265(SG) / 236(SB)
Gross Weight (lbs.)		307(SG) / 279(SB)
# of Swing Door		2
# of Shelves		4
Shelf size (L x D) (in.)		22 7/8 x 18
# of Casters	 <p>6EA</p>	

Design and specifications subject to change without notice.

Actual shipping weight may differ due to extra packing materials for product protection.

*Depth does not include 1" for door handle (SG Models).

†Height does not include 2" for rear spacers.

† Height does not include 5" for caster height.

■ **WARRANTY : 3 Year Parts and Labor Warranty**
Additional 2 Year Warranty on Compressor

- **Anti-corrosion coated evaporator**
- **Self-contained system**
- **Door locks standard**
- **4" dia. swivel casters standard**
- **2" dia. casters available (optional)**
- **6" height adjustable legs available (optional)**

■ **OPTIONAL ACCESSORIES :**

- 2" caster for underbar series, 1/2" diameter: P0165B0100 (non-brake), P0165B0110 (w/ brake)
- 5" caster, 1/2" diameter & 13 TPI: M726500100 (non-brake), M726500200 (w/ brake)
- 6" adjustable stainless steel leg: P0121P0100
- Additional PE coated wire shelf: P0178S0410 (Left/Right)

Ver.20171025

PLAN VIEW

(unit : inch)

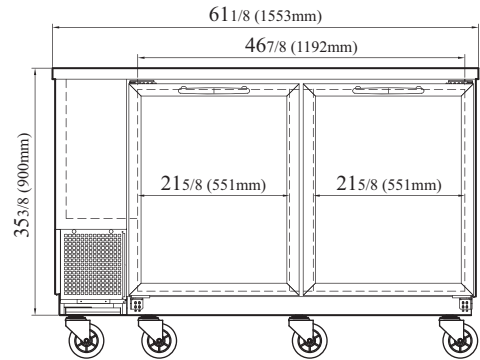

TBB-24-60SG-N FRONT VIEW

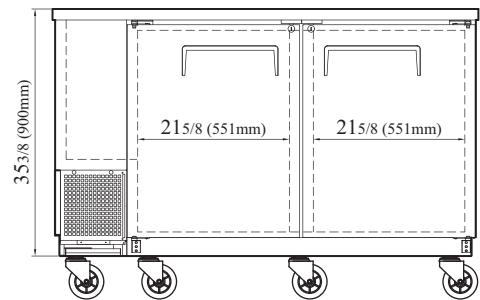

TBB-24-60SB-N6 FRONT VIEW

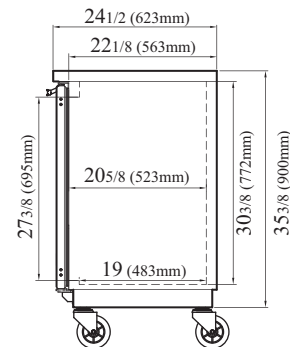

TBB-24-60SG-N SIDE VIEW

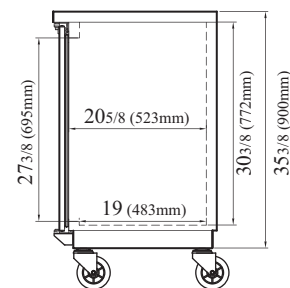

TBB-24-60SB-N6 SIDE VIEW

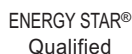

- Turbo Air : 800-627-0032
- GK : 800-500-3519
- Warranty : 800-381-7770
- AC : 888-900-1002

