



MBTR72-S



## MBTR SERIES

### Top Mounted Solid Door Reach-In Refrigerators

#### MODELS

- MBTR23-S
- MBTR49-S
- MBTR72-S

### FEATURES

#### STANDARD ELECTRONIC CONTROL

- Digitally displays inside temperature
- Temperature display easily adjustable from °F to °C
- Allows user to monitor and adjust temperature set point within normal temperature range
- Visual and audible door open alarm
- Clean condenser alarm (displays "CL" every 6 months)
- Decreases service time and calls

#### CONSTRUCTION

- Curved corner design creates a stylish appearance and reduces chances of injury in slip-and-fall accidents
- Stainless steel exterior on front, sides and doors
- Exterior top, bottom and back are galvanized steel
- Interior liner and door panel are stainless steel
- Foamed-in-place with low ODP polyurethane insulation
- Wall thickness:
  - Sides ..... 2 1/4"
  - Top and back..... 2 1/4"
  - Bottom ..... 2 1/4"

- 4" diameter casters
- Four casters on one- and two-door models and six on three-door models (two casters on each model are locking type)
- Four adjustable heavy-duty shelves per door

#### DOORS

- Heavy-duty pull handles
- Self-closing at 96°
- Hold open feature at 110°
- Individual door locks
- Self-adjusting magnetic gaskets
- Interior LED light activated by switch for each door
- Anti-condensate heater wires on door openings
- Standard door swing configuration:
  - MBTR23-S ..... hinged right
  - MBTR49-S ..... left door hinged left, right door hinged right
  - MBTR72-S ..... left door hinged left, middle door hinged right, right door hinged right
- Field reversible doors on single door models (requires left hand hinging kit)
- Door width: 27"

#### REFRIGERATION

- Self-contained top mount refrigeration system
- Capillary tube controls refrigerant flow
- Automatic defrost
- Efficient hot gas condensate removal
- Refrigerant: R290
- Operating temperature range: 34° to 38°F (1° to 3° C)

#### WARRANTY

- **Standard limited three year parts and labor**
- **Additional two year coverage on compressor part**

#### OPTIONS

- Extra wire shelves
- 6" adjustable feet
- Left hand hinging kit (one-door models only)
- Pan rack

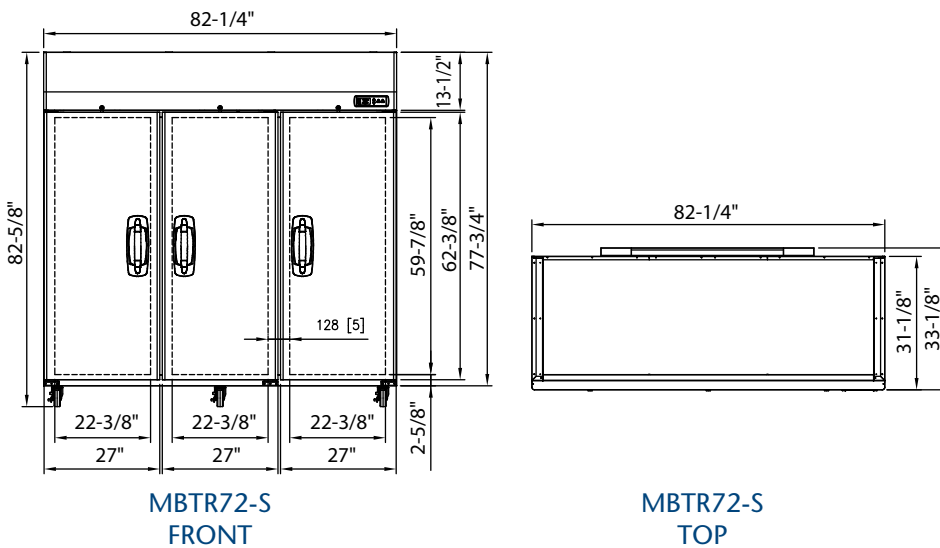
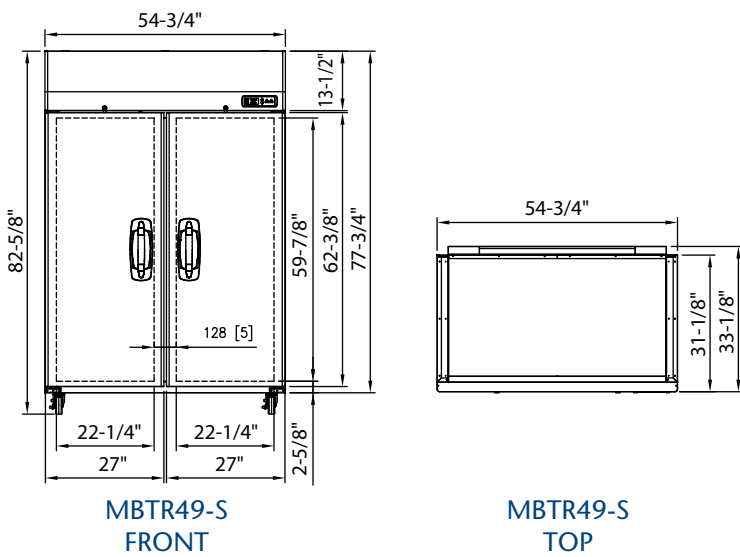
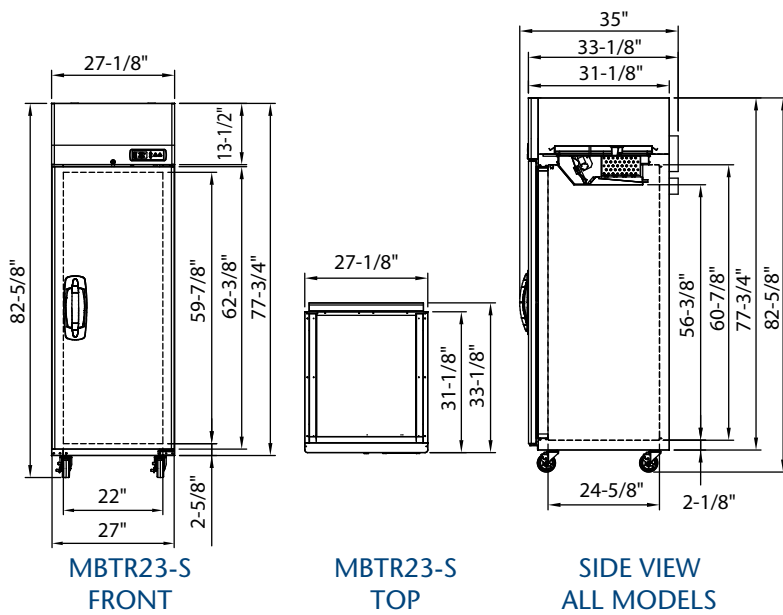

**SPECIFICATIONS**

Models	MBTR23-S	MBTR49-S	MBTR72-S
Crated Weight (lbs) (kg)	247 (112)	368 (167)	516 (234)
Crated Height (in) (mm)	83-1/2 (2121)	83-1/2 (2121)	83-1/2 (2121)
Crated Width (in) (mm)	29 (737)	57 (1448)	85 (2159)
Crated Depth (in) (mm)	35 (889)	35 (889)	35 (889)
Interior Height (in) (mm)	56-3/8 (1432)	56-3/8 (1432)	56-3/8 (1432)
Interior Width (in) (mm)	22 (559)	49-1/2 (1257)	77-1/8 (1959)
Interior Depth (in) (mm)	24-5/8 (625)	24-5/8 (625)	24-5/8 (625)
Overall Height (in) (mm) *	82-5/8 (2099)	82-5/8 (2099)	82-5/8 (2099)
Overall Width (in) (mm)	27-1/8 (689)	54-3/4 (1391)	82-1/4 (2089)
Overall Depth (in) (mm)	33-1/8 (841)	33-1/8 (841)	33-1/8 (841)
Gross Cubage (CuFt) (L)	19.5 (552)	42.7 (1209)	66.0 (1869)
Number of Shelves	4	8	12
Shelf Area (SqFt) (SqM)	18.75 (1.74)	37.5 (3.48)	56.25 (5.23)
Number of Casters	4	4	6
Condensing Unit Size	3/8 HP	3/8 HP	3/8 HP
Refrigerant	R290	R290	R290
Electrical Characteristics	115/60/1	115/60/1	115/60/1
Cord & Plug Furnished	Yes	Yes	Yes
NEMA Plug Configuration	5-15P	5-15P	5-15P
Total Amp Draw	3.5	3.7	4.5

Specifications subject to change without notice.

\* The overall heights shown in the table and drawings are with casters.

**NOTE:** Cabinet designed for optimum performance in air-conditioned area at 75°F ambient and 55% relative humidity. All specifications subject to change without notice.