

Item #360CF8

Commercial Chest Freezer

7.4 Cu. Ft.

Features:

- 7.4 cu. ft. of bulk food storage space
- (1) Insulated lid for better temperature retention
- Durable, white powdered coated exterior
- Embossed aluminum interior
- (1) Coated wire basket for added storage and organization
- Drain plug for easy cleaning and self-defrosting
- Includes (4) 2.5" casters for added mobility
- Temperature range of -13°F to 0°F



Description:

An excellent choice for bulk storage at your convenience store, ice cream shop, restaurant, or market, this Galaxy CF8 commercial chest freezer gives you 7.4 cu. ft. of space to store a wide variety of product! This unit reliably maintains temperatures between -13 to 0 degrees Fahrenheit so you can safely hold anything from meat to ice cream or frozen yogurt. A basket is even included to hold smaller go-to items closer to the top of the freezer for improved organization and efficiency.

Cabinet temperatures are consistently maintained thanks to a 1/7 hp compressor that uses R-134a refrigerant for dependable operation in ambient temperatures up to 90 degrees Fahrenheit. The powder coated steel exterior and embossed aluminum interior are durable, sleek, and extremely simple to clean, while a drain is included to make manual defrosting a breeze as well! This chest freezer requires a 115V electrical connection for operation.

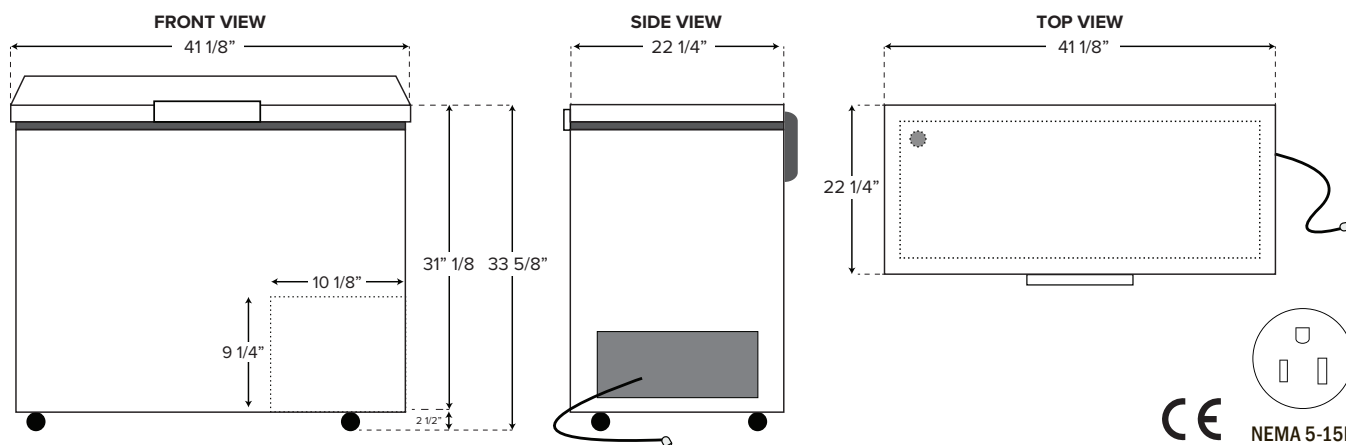

Dimensions

Exterior Dimensions	41½"W x 22¼"D x 33¾"H (includes 2½" casters)
Interior Dimensions	35"W x 16½"D x 25"H
Net Volume (cu. ft.)	7.4 cu. ft.
Net Weight	93 lbs.
Packaging Dimensions	44¼"W x 25¾"D x 35"H

Construction

Number of Doors	1
Exterior Material	White powder coated steel
Interior Material	Embossed aluminum
Insulation Material	Foamed in place polyurethane
Number of Baskets	1
Basket Dimensions	10½"W x 18"D x 10½"H
Basket Material	Plastic coated wire
Drain Plug	Located at back left

Cooling

Temperature Range	-13° to 0°F
Refrigerant	R-134a
Max. Ambient Temperature	90°F
Defrosting	Manual
Temperature Controller	Manual (0-7 scale)
Horsepower	1/7

Electrical

Voltage	115
Wattage	101
Amps	0.65
Hz	60
Phase	1
Plug Type	NEMA 5-15P
Electrical Cord Length	75"

1 Year Limited Replacement Warranty

Unless otherwise stated, Galaxy Equipment warrants to the original purchaser of new, qualified Galaxy Equipment units (and all parts thereof), that such equipment will be free from defects in material and workmanship for a period of 1 year from the date of delivery.

If a qualified product is found to be defective during this period, Galaxy Equipment will repair the defective unit, replace any defective parts, or replace the defective unit.

What This Warranty Does Not Cover:

Galaxy Equipment will not warrant coverage for component failure or other damages that arise under the following conditions:

- Failure to install and/or use unit within proper operating conditions specified by Galaxy Equipment
- Failure to properly maintain the unit. This includes, but is not limited to, basic preventative maintenance such as cleaning the condenser coil.
- Products sold or used outside of the United States

Additionally, no claims can be made against this warranty for spoilage of product, loss of sales or profits, or any other consequential damages. Normal wear type parts, such as light bulbs and gaskets, are not included in warranty coverage.

For Warranty Inquiries or Service:

To obtain warranty service, contact the location that you purchased the product from:

www.WebstaurantStore.com:

Call 717-392-7472. You must have your order number ready when contacting.

The Restaurant Store:

If you purchased this unit from your local store location, please contact your store directly. A list of store locations can be found by visiting: <http://www.therestaurantstore.com/store-directory.html>

www.TheRestaurantStore.com:

If you purchased this unit online, call 717-392-7261. You must have your order number ready when contacting.

Failure to contact the designated location prior to obtaining equipment service may void your warranty.