

Project \_\_\_\_\_  
Item \_\_\_\_\_  
Quantity \_\_\_\_\_  
CSI Section 11400  
Approved \_\_\_\_\_  
Date \_\_\_\_\_

# 403P Series

Self-Contained Compact Work Top Freezer

403P Series

## Models

- 403P Single section freezer



403P

## Standard Features

- Features Delfield's exclusive ABS interior. ABS is extremely durable - it won't dent, chip or corrode and is backed by a limited lifetime warranty
- Stainless steel front, sides and top
- One epoxy coated wire shelves, standard installed per unit
- Environmentally friendly R290 refrigerant
- Foamed in place environmentally friendly, Kyoto Protocol Compliant, Non ODP (Ozone Depletion Potential), Non GWP (Global Warming Potential) polyurethane cuts energy costs
- Black recessed quick grip handle
- Rugged 6" high heavy duty metal legs
- Door hinging available on either right or left, right side is standard
- 60-cycle single phase electrical system
- 6' cord and plug supplied
- Three year parts and labor warranty and an additional two year compressor parts warranty

## Options & Accessories

- Stainless steel back
- Plastic laminate on front
- Additional wire shelves
- Stainless steel single-tier overself
- 3" (8cm) diameter casters
- 5" (12.7 cm) diameter casters
- Door lock (original order only; not field installable; per door)
- Full-size composite-type cutting top

## Specifications

**Exterior bottom** shall be heavy-gauge galvanized metal. Exterior ends shall be heavy-gauge stainless steel.

**Exterior top:** One-piece, 22-gauge stainless steel with front edge turned down to form nosing and rear edge turned up to form a 2" (5.1 cm) thick by 4" (10.2 cm) high backsplash.

**Base interior:** One-piece thermoformed ABS plastic material, with integral shelf supports. Base shall be fully insulated with high-density foamed-in-place environmentally friendly, Kyoto Protocol Compliant, Non ODP (Ozone Depletion Potential), Non GWP (Global Warming Potential) polyurethane.

**Door** shall have a heavy-gauge stainless steel exterior, with a thermoformed ABS plastic interior liner, and shall be fully insulated. Door handles shall be black, recessed ABS. Cabinet shall have (1) adjustable epoxy-coated wire shelves installed.

Equipment shall be mounted on 6" (15.2 cm) high metal legs with black enamel finish.

**Electrical Connections:** 115 volt, 60 Hertz, single phase. Unit shall have a 6' (1.8 m) long electrical cord and NEMA 5-15P plug. Cord and plug shall be located

on the rear of the cabinet 16" (40.6cm) above floor, 5" from left side.

**Model 403P Freezers:** Refrigeration system shall use R290 refrigerant. Compressor shall be 1/5 h.p., with condenser coil, temperature control and hot gas condensate evaporator mounted on rear of cabinet. Evaporator coil shall be mounted on the interior rear wall of the cabinet. Refrigerant flow shall be controlled by a capillary tube. Cabinet shall maintain -5°F to 0°F (-21°C to -18°C) interior cabinet temperature.

System is controlled using Delfield's ACT-Advanced Control Technology electronic temperature control, which provides improved pull down times, reduces compressor cycling and longer compressor life with lower energy consumption.



R290

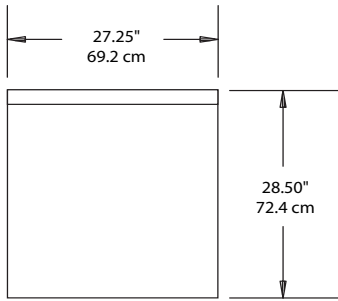

Plan View

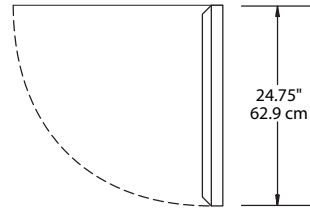

Standard door hinging is on right  
Hinging may be reversed  
But a new door is required

Door Clearance Detail

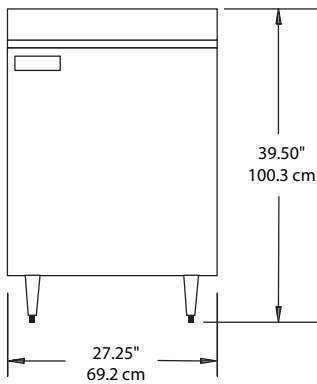

Elevation View

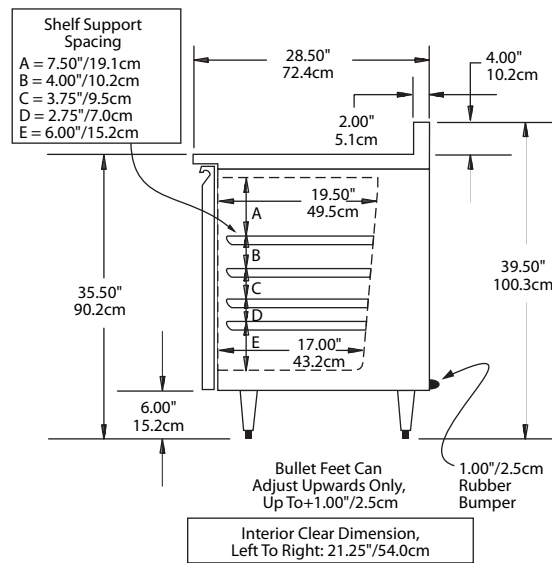

Right End View

**INSTALLATION NOTE:**

Refrigeration system is designed so that air will flow under the unit, through the compressor area and out the top rear of the unit. Any restriction to this air flow path will void the warranties.

Specifications								
Model	# of Shelves	Volume	h.p.	V/Hz/Ph	Amps	nema plug	Ship Weight	Energy (KWH/Day)
403P	2	5.7ft3	1/5	115/60/1	4.5	5-15P	184lbs (83kg)	2.59

Welbilt reserves the right to make changes to the design or specifications without prior notice.