

REVISION HISTORY			
REV	DESCRIPTION	DATE	APPROVED
-	Engineering Release	08/14/2018	Todd Stone

Dimensions shown are actual physical dimensions. Additional clearances to the cabinetry are dependent on the tolerances of the cut-out. We recommend an additional .250 inches around all openings but this can be reduced if the tolerances are controlled. Please refer to the installation manual for additional clearances and clearances to combustibles.

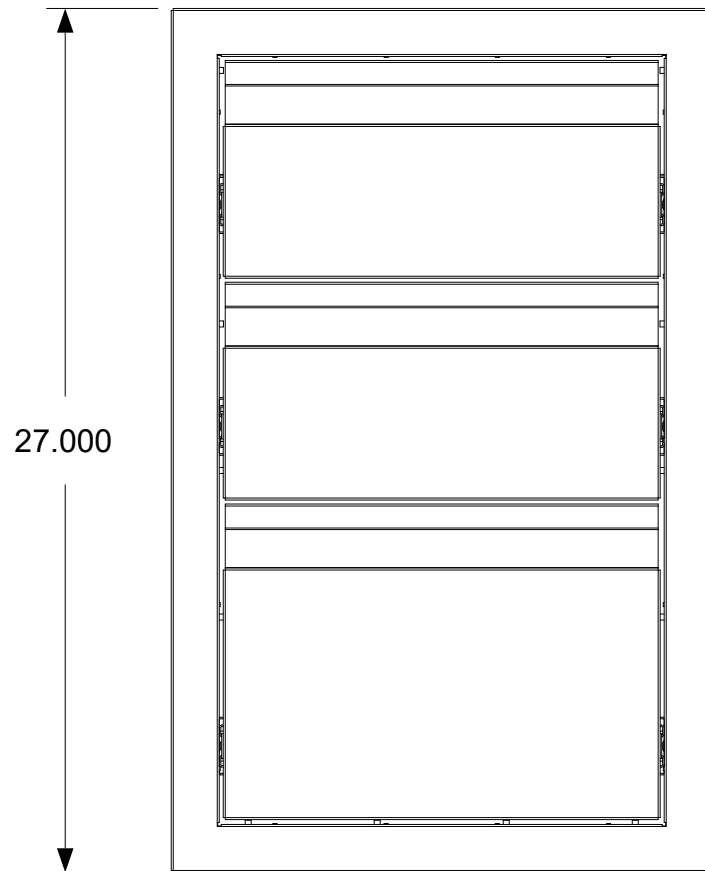
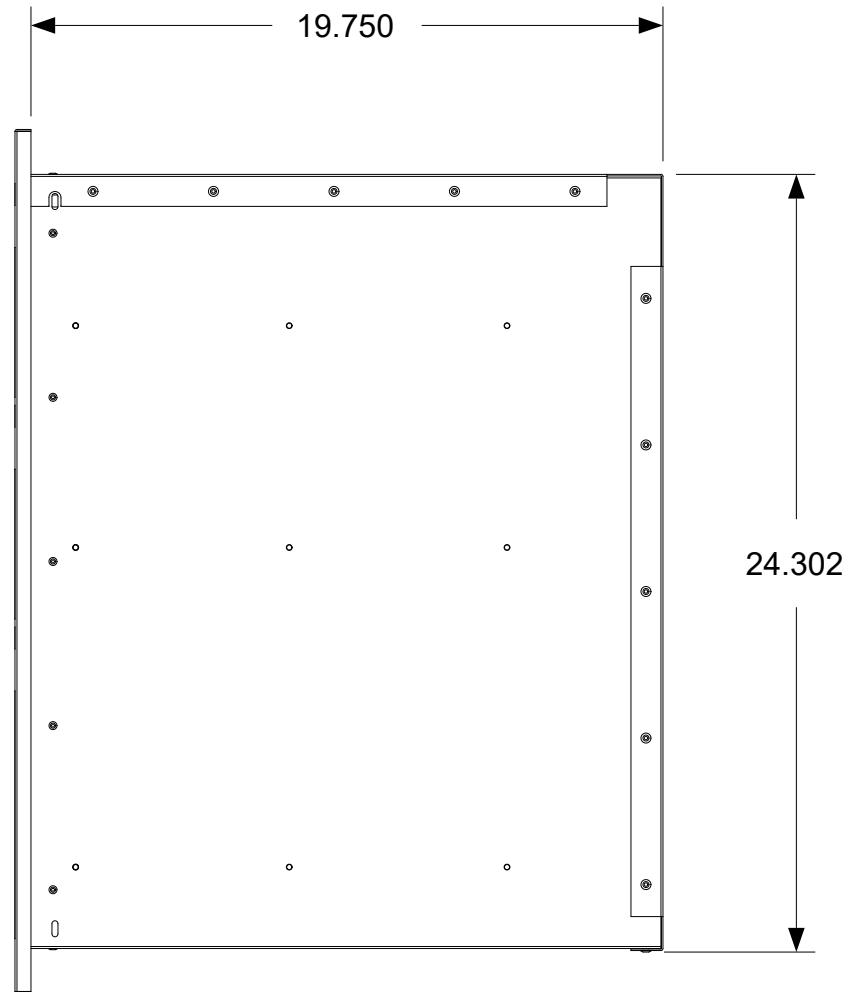
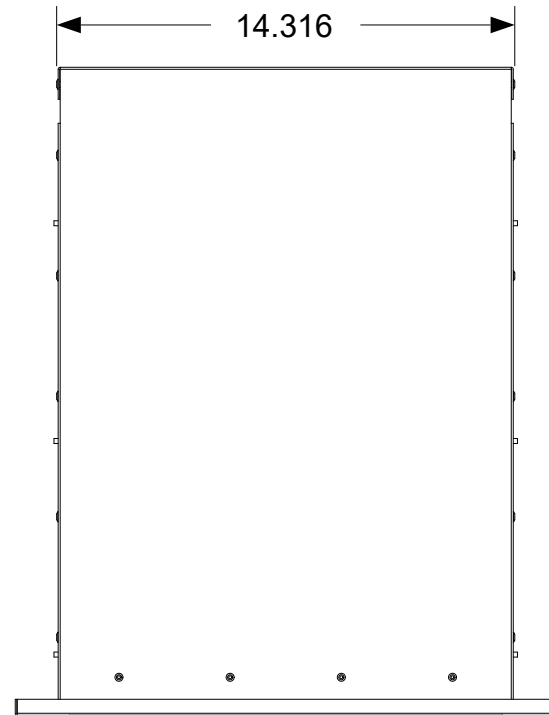
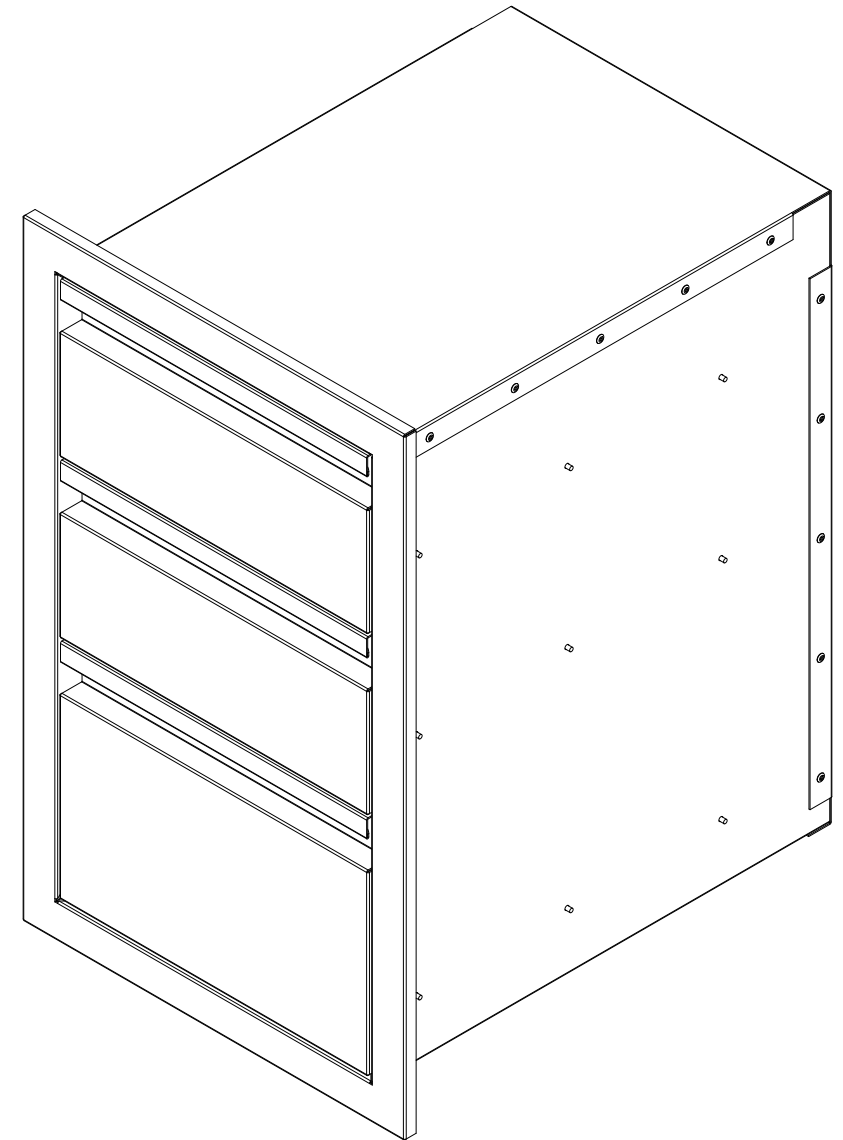

CROWN VERITY

37 Adams Blvd., Brantford, Ontario, N3S 7V8
P: (519) 751-1800 www.crownverity.com

Gauge	N/A	Dimensions are in inches Linear Tolerance: +/- .015 Bend Tolerance: +/- .020 Angular Tolerance: +/- 0.5 Radial Tolerance: +/- .005
Weight (Kg)	N/A	
K Factor	N/A	
Finish	#4	
Material	SS 304	
DRAWN BY: Todd Stone		

TITLE			
Built In 3 Drawer Cabinet			
SIZE	Customer	DWG NO	REV
B	Crown Verity	CV-3D1	-
SCALE	1:6	08/14/2018	SHEET 1 of 1