



www.AvantcoRefrigeration.com

PROJECT: _____

MODEL: _____

ITEM #: _____ QUANTITY: _____

APPROVAL: _____ DATE: _____

CAC Series Dual Service Display Merchandiser

MODEL #224BCAC36

CAC SERIES - Black Horizontal Air Curtain Merchandiser
Display your grab and go items in style while keeping them chilled.

CABINET CONSTRUCTION

Durable stainless steel exterior and interior.

Curved side glass

REFRIGERATION SYSTEM

3/4 hp compressor uses R290 refrigerant. Operation requires a 115V electrical connection.

Maintains a temperature range from 35-41 degrees Fahrenheit.

Includes automatic defrost setting.

STORAGE

Corrosion-resistant stainless steel shelving holds up to 44 lb.

MODEL FEATURES

Sliding glass door for easy access to display contents.

Intuitive, easy to read pre-programmed electronic controls.

Foamed-in-place polyurethane insulation for temperature retention.

SPECIAL FEATURES

- Dual service design promotes both self-service impulse sales and provides a display area to show off specialty goods.
- Bright, energy efficient LED lighting illuminates the contents of the case.
- Energy-saving night cover included for off hours.
- Front curved glass is anti-fog so the interior is always clearly visible.
- Casters allow for unit to be easily moved for cleaning and maintenance.
- Internal condensate evaporator eliminates the need for drain connection. Optional drain located on the rear of unit to prevent overflow.
- Eco-friendly R290 hydrocarbon refrigerant.
- Low noise emission makes it ideal for front-of-house use.
- 115V, 3/4 hp



03/2021

WARRANTY

RESIDENTIAL: Avantco assumes no liability for parts or labor coverage for component failure, factory defect or any other damages for units installed in non-commercial foodservice or residential applications.



Parts & Labor



Compressor

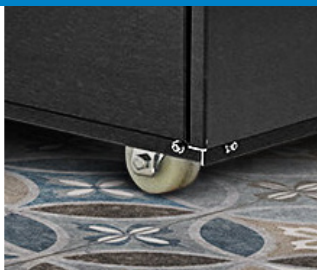

CAC Series

Dual Service Display Merchandiser



www.AvantcoRefrigeration.com

MODEL #224BCAC36

TECHNICAL DATA

Dimensions

Exterior Dimensions	35 ³ / ₈ "W x 31 ¹ / ₂ "D x 59 ¹ / ₈ "H
Interior Dimensions	--
Capacity	12.5 cu. ft.
Net Weight	456 lbs.
Gross Weight	522 lbs.
Packaging Dimensions	40"W x 35 ³ / ₁₆ "D x 65"H

Cooling

Temperature Range	35°F - 41°F
Refrigerant	R290
Max. Ambient Temperature	75°F
Max. Humidity	55%
Defrosting	Automatic
Temperature Controller	Digital
Horsepower	3/4 HP
BTU (BTU/hr)	4895

Construction

Exterior Material	Stainless Steel + Glass
Interior Material	Stainless Steel 304
Insulation Material	Polyurethane
# of Shelves and Dimensions	2 Shelves/ 14 ⁵ / ₈ " x 9"
Shelf Load Capacity	44 lb.
Shelf Material	Clear Tempered Glass

Electrical

Voltage	115
Amps	7.8
Hz	60
Phase	1
Plug Type	NEMA 5-15P
Electrical Cord Length	71"

PLAN VIEW

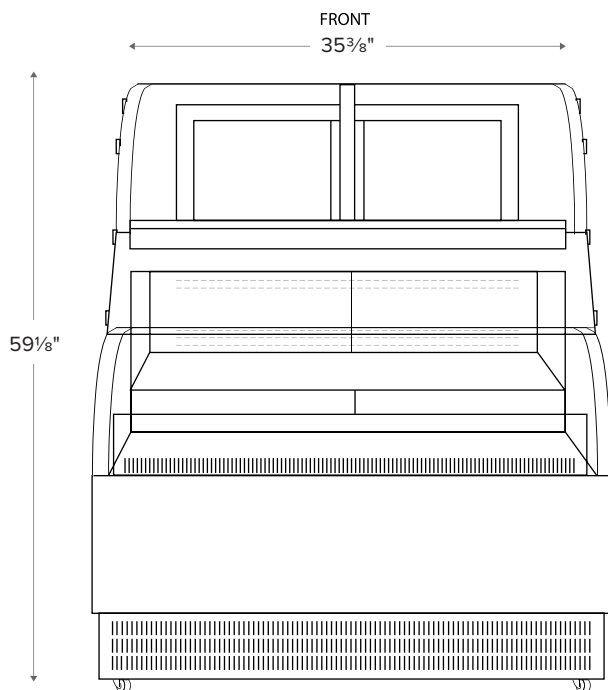

FRONT

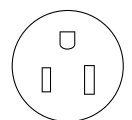
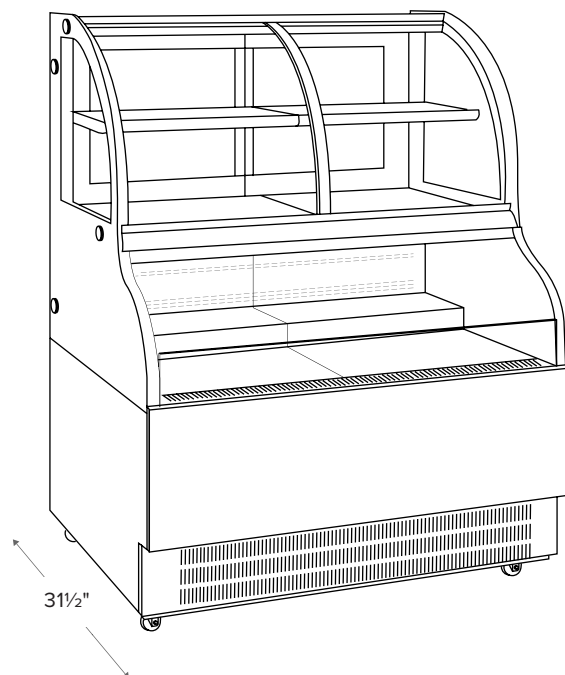

NEMA 5-15P