



BCM-101E-PT

# BCM-101E-PT

Single Electric Pass-Through  
Combination-Oven/Steamer with  
Manual Control



Project \_\_\_\_\_

Item No. \_\_\_\_\_

Quantity \_\_\_\_\_

- Standard rack with 3.35" (85mm) spacing holds eight 12" x 20" x 2-1/2" deep North American hotel pans
- Optional rack with 2.56" (65mm) spacing holds ten 12" x 20" x 2" deep Gastronorm pans

Refer to operator manual specification chart for listed model names.

### CONSTRUCTION

- 304 Stainless steel exterior and interior
- Dual pane tempered viewing windows on the front and back of the oven. Windows have hinged inner glass for easy cleaning
- 2" (50mm) fixed drain in the bottom center of cavity
- Door mounted drip tray reduces the risk of wet, slippery floors
- Automatic door stops in positions 110° and 180° for ease of loading and unloading and improved safety.
- Left hinge door is field convertible to the right side (with the purchase of conversion kit)
- Two step safety door latch. The first step stops the fan.

### OPERATION

- Multiple cooking modes include hot air, combi 1 (30-40% steam), combi 2 (60-80% steam), retherming, steaming, low-temperature steaming, forced steam, and preheating
- Automated CombiWash, closed circuit cleaning system features very low water and detergent consumption and no contact with chemicals. No proprietary chemicals required, see owner's manual for detergent guidelines.
- Semi automatic deliming system
- Built in steam generator produces pure, dry steam
- Automatic boiler flushing system
- User friendly control with dial and digital display
- Control stores up to 50 recipe programs with 10 cooking stages each
- Reversible 9 speed fan for optimum baking and roasting results
- Programmable time delay start
- 85°-480°F (30°-250°C) temperature range, 575°F (300°C) preheating
- Low water indicator
- Restart button on the back of the oven enables the operator to restart the last cooking cycle

### STANDARD FEATURES

- External core temperature probe with multiple measuring points. User-friendly location reduces strain on the probe
- 21-1/2" tall stainless steel stand with runners & adjustable feet
- 5 wire shelves
- Bright halogen lights for superior visibility
- Built in hand shower
- Removeable cleaning chemical bottle shelf
- Start-up inspection service by factory authorized service agent
- One year parts and labor oven warranty\*

\* For all international markets, contact your local distributor.

### OPTIONS AND ACCESSORIES (AT ADDITIONAL CHARGE)

- **Legs and Stands**
  - 21-1/2" tall stainless steel stand with runners & casters
  - Adjustable feet for table top installation
- **Banqueting Accessories**
  - Pan cassette with 2.56" (65mm) spacing
  - Pan cassette with 3.35" (85mm) spacing
  - Plate cassette with 2.56" (65mm) spacing holds 32 plates
  - Plate cassette with 3.35" (85mm) spacing holds 27 plates
  - Transport trolley, to move the cassette
  - Cassette support platform
  - Insulated thermal blanket with vent
- Wire oven rack
- Right hinge door
- Backflow preventer
- Extra year warranty

### OPTIONS AND ACCESSORIES (AT NO CHARGE)

- Optional rack with 2.56" (65mm) spacing



Intertek

### BLODGETT OVEN COMPANY

www.blodgett.com • 44 Lakeside Avenue, Burlington, VT 05401 • Phone: (802) 658-6600 • Fax: (802) 864-0183



# BCM-101E-PT



APPROVAL/STAMP

DIMENSIONS ARE IN INCHES (MM)

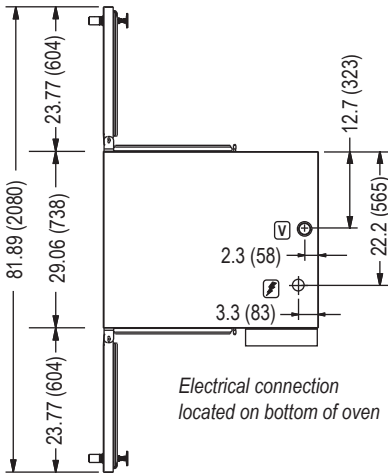

TOP VIEW

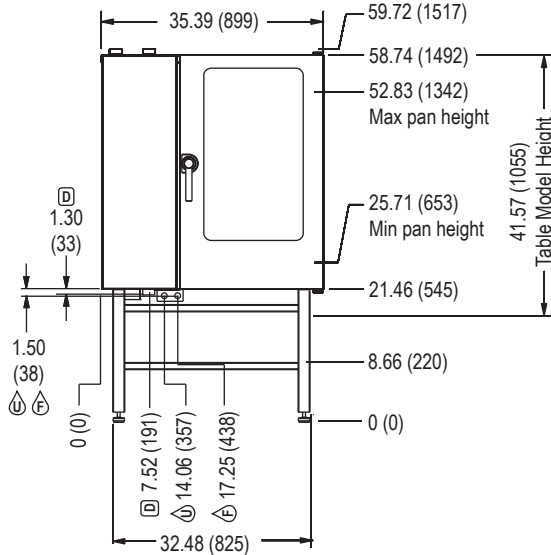

BACK VIEW

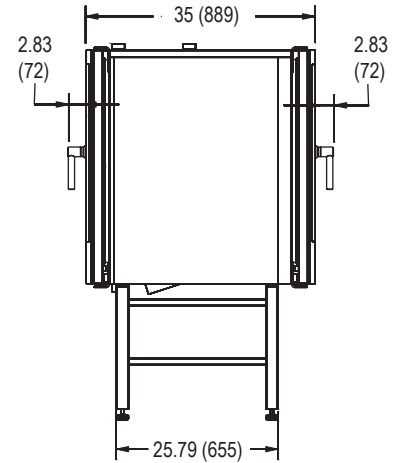

SIDE VIEW

**SHORT FORM SPECIFICATIONS:** Provide Blodgett Combi model BCM-101E-PT combination-oven/steamer. The BCM-101E-PT has a 2 piece rack system with 3.35" (85mm) rack spacing that holds eight 12" x 20" x 2-1/2" deep North American hotel pans. The optional 2 piece rack system with 2.5" (65mm) spacing holds ten 12" x 20" x 2" deep Gastronorm pans. Unit shall have 304 stainless steel exterior and interior. Oven door shall have dual pane tempered viewing window with hinged inner glass for easy cleaning. Multiple cooking modes include hot air, combi 1 (30-40% steam), combi 2 (60-80% steam), retherming, steaming, low-temperature steaming, and preheating. Unit shall have the ability to cook with pressureless steam, hot air, or combination of steam and hot air. Steam generator shall be separate from the cooking compartment and shall drain and flush automatically. Unit shall have bright halogen lights for superior visibility. Standard control includes user friendly digital display with dial, ability to store up to 50 recipe programs with 10 stages per recipe, and time delay start. The reversible 9 speed fan provides optimum baking and roasting results. Automated CombiWash, closed circuit cleaning system features very low water and detergent consumption and no contact with chemicals. Semi automatic deliming system. One-year parts and labor warranty. Provide start-up inspection service by a factory authorized service agent. Provide options and accessories as indicated.

## DIMENSIONS:

Floor space: 35.39" x 32.72" (899 x 831mm)

### Unit height:

Oven on stand 58.74" (1492mm)

Table model 41.57" (1055mm)

## OVEN CLEARANCES:

From combustible and non-combustible construction

Right 4" (102mm)

Left 0" (0mm)

Blodgett recommends and 12" (305mm) be maintained on the control side for servicing.

## MINIMUM ENTRY CLEARANCE:

Uncrated 29.06" (738mm)

Crated 38" (965mm)

## POWER SUPPLY:

Voltage	KW	Phase	Amperage
208 VAC	18	3	50
240 VAC	18	3	44
480 VAC	18	3	22

Other voltages available, contact factory

## WATER SUPPLY & DRAIN:

Good quality water feed is the responsibility of the owner. Water quality must be within the following general guidelines.

TDS: 40-125 ppm

Hardness: 35-100 ppm

pH: 7.0 - 8.5

Silica: <13 ppm

Chlorides: <25 ppm

Chlorine: <0.2 ppm

Chloramine: <0.2 ppm

The best defense against poor water quality is a water treatment system designed to meet your water quality conditions. Blodgett offers optional systems from Optipure.

Pressure: 40(min)-50(max) PSI

Connections: 2" drain connection - max. drain temperature 140°F (60°C)

3/4" garden hose cold water

Appliance is to be installed with backflow protection in accordance with federal, state or local codes.

## SHIPPING INFORMATION:

Approx. weight: 545 lbs. (247 kg)

### Crate size:

Oven 40" H x 47" W x 38" D (1016 x 1194 x 965 mm)

Stand 36" H x 42" W x 35" D (914 x 1067 x 889 mm)

**NOTE:** The company reserves the right to make substitutions of components without prior notice

## BLODGETT OVEN COMPANY

www.blodgett.com • 44 Lakeside Avenue, Burlington, VT 05401 • Phone: (802) 658-6600 • Fax: (802) 864-0183