

Project _____

Item 186VME1 Quantity _____

Approval _____ Date _____

Galaxy VME1 External Vacuum Packaging Machine with 12" Seal Bar

Item #186VME1

Special Features

- Compact design with large 12" seal bar
- Extended seal time and pulse features seal thick, heavy-duty bags
- Locking lid ensures sealing process remains uninterrupted
- Digital control panel for smooth operation; seal and vacuum & seal options
- Great for extended storage or sous-vide cooking

Technical Data

Width	15 Inches
Depth	6 5/8 Inches
Height	2 15/16 Inches
Seal Bar Length	12 Inches
Seal Wire Width	2 Millimeters
Hertz	60 Hertz
Phase	1 Phase
Voltage	120 Volts
Wattage	100 Watts
Features	Pulse Option Vacuum Canister Port
Number of Seal Bars	1
Power Type	Electric
Style	External Strip
Vacuum Packaging Machine Type	Automatic



Certifications



Compatible Items

(#186PHOSE) Galaxy PHOSE Vacuum Canister Hose for VME1

Technical Drawing

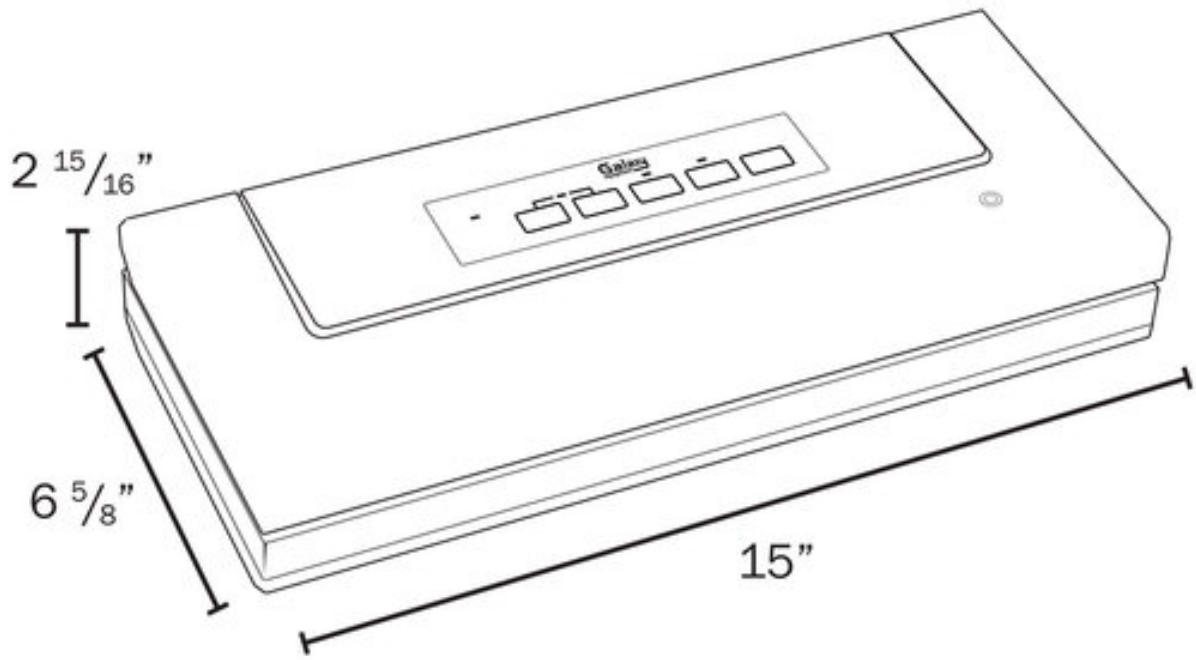

⚠ WARNING: This product can expose you to chemicals including lead, which are known to the State of California to cause cancer, birth defects, or other reproductive harm. For more information, go to www.p65warnings.ca.gov.