



# VACPAK-IT

#186VMC100P

## CHAMBER VACUUM PACKAGING MACHINE WITH OIL PUMP & 10¼" SEAL BAR

- Quick 20 to 40 second vacuum time and 6 second seal time; times are adjustable
- Easy-to-read digital vacuum pressure digital includes simple, intuitive controls
- 304 series stainless steel body for strength; transparent lid for product visibility
- Pressure gauge included
- Oil pump is easy to monitor and fill for continued use
- Seal bar easily removable for cleaning and maintenance

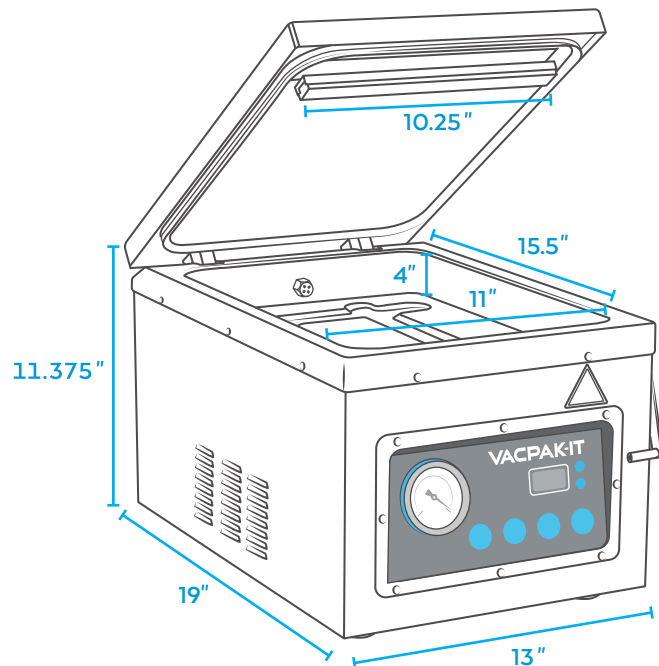

WIDTH	13"
DEPTH	19"
HEIGHT	11.375"
SEAL BAR LENGTH	10.25"
CHAMBER WIDTH	11"
CHAMBER DEPTH	15.5"
CHAMBER HEIGHT	4"
SEAL BAR(S)	Single

STYLE	Chamber
PUMP TYPE	Oil
AMPS	8.33 Amps
HERTZ	60 Hz
PHASE	1
VOLTAGE	120V
WATTAGE	1000W
HORSEPOWER	1/4HP