



BEVERAGE-AIR

3779 Champion Blvd., Winston-Salem, NC 27105
1-888-845-9800 Fax# 1-336-245-6453
<http://www.Beverage-Air.com>

CUSTOMER'S CHOICE FOR A HOT KITCHEN
Tested & Certified to Ambient Class of 100°F

3 Year Parts/Labor Warranty Additional 2 Year Compressor Warranty

WORKTOP COOK STAND REFRIGERATOR

Beverage-Air's cook stand refrigerators are designed to accommodate countertop cooking equipment and feature a full marine drip-guard to prevent spills from dripping over the edge. Refrigerated drawers provide ample food product storage. Working height of 26 5/8" on heavy-duty six-inch (6") casters.

CABINET CONSTRUCTION

Heavy-duty construction with stainless steel on top, front, sides, rear and drip guard top. Interior of cabinet is constructed of corrosion-resistant stainless steel. Drawers are equipped with heavy-duty workflow handle. Cabinet integrity is reinforced by use of structural columns. Cabinets are insulated with foamed-in-place polyurethane insulation of 2" thickness for added strength and maximum energy efficiency. Cabinet back and bottom are constructed of galvanized steel. Interior cabinet is made of corrosion resistant stainless steel.

Exterior solar digital thermometer with battery backup is standard.

DRAWER CONSTRUCTION

Drawer frames are constructed of heavy duty stainless steel and are supported on stainless steel telescoping drawer slides with three stainless steel roller bearing wheels for maximum support of stored food product. Heavy duty pan divider supports are supplied. Foodservice pans are not included. A snap in type vinyl magnetic gasket is attached to each drawer for positive seal. Beverage-Air provides standard lifetime warranty on drawers and slides on this series.

REFRIGERATION

Self-contained refrigeration system utilizes R134a refrigerant metered by a capillary tube system. Automatic (hot gas) condensate evaporation is provided. Interior forced air system, with high humidity evaporator coils, provide the ideal environment for food preservation. Removable front thermometer panel and grille allows for easy access to complete lift-out refrigeration system.

Item No. _____
Quantity _____

**WORKTOP COOK STAND
REFRIGERATORS
4 DRAWER EQUIPMENT BASE
WTRCS72 SERIES**

**MODELS:
WTRCS72-1
WTRCS72-1-76**

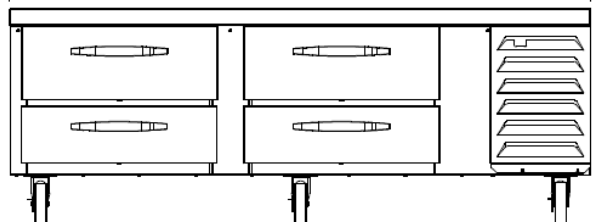

**IMAGES COMING
SOON**

ELECTRICAL CONNECTION

Units pre-wired at factory and include 8' long cord and plug set.



115/60/1
NEMA-5-15P

Available From:



*Note: Not all markings may apply to all model variations.

Model Specified _____	Store# _____
Location _____	Quantity _____



BEVERAGE-AIR

PLAN VIEWS

Work top Refrigerator, Cook Stand Model Series
Models: WTRCS72-1, WTRCS72-1-76

MODEL	WTRCS72-1	WTRCS72-1-76
EXTERNAL DIMENSIONAL DATA		
Length Overall (inches)	72"	76"
Length Overall (mm)	1828	1930
Depth Overall (inches)	32"	32"
Depth Overall (mm)	813	813
Height Overall— (inches)	26 5/8"	26 5/8"
Height Overall— (mm)	651	651
Number of drawers	4	4
Depth with Drawer Open 90 °	60"	60"
Top Load Rating (lbs)	900	900
Top Load Rating (kg)	408	408
ELECTRICAL DATA		
Full Load Amperes 115/60/1	4.5	4.5
ENERGY CONSUMPTION (KWH)		
	TBD	TBD
REFRIGERATION DATA		
Horsepower	1/5	1/5
WEIGHT DATA		
Gross Weight (Crated lbs)	569	576
Gross Weight (Crated kg)	245	261

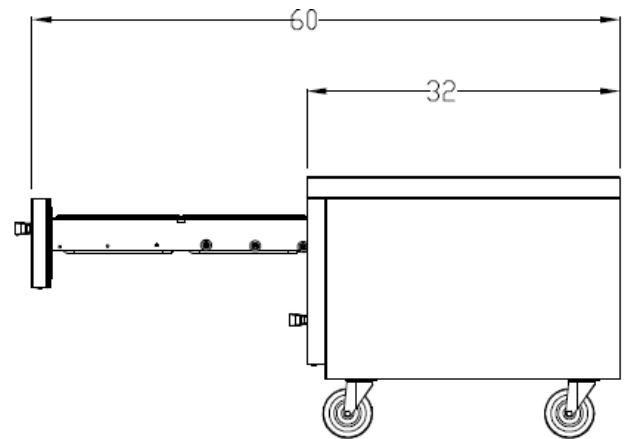
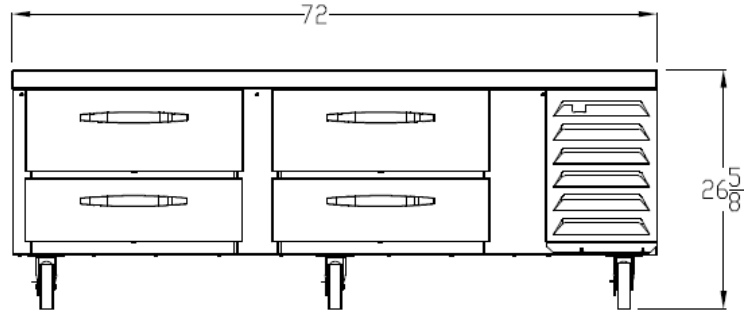

Note: Not all markings may apply to all model variations.

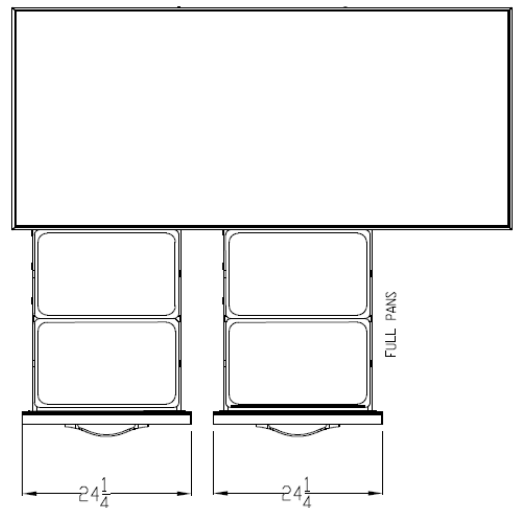
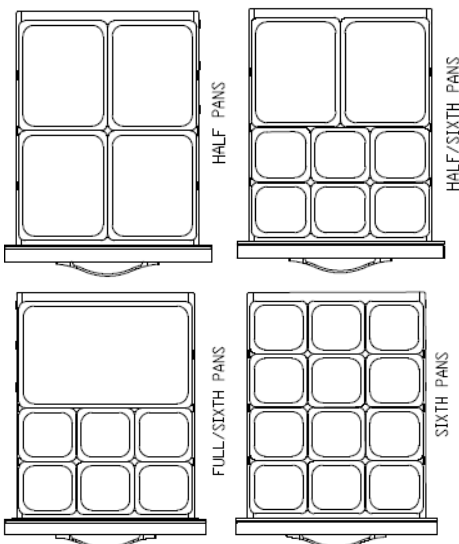

BEVERAGE-AIR® CORPORATION

3779 Champion Blvd. • Winston-Salem, NC 27105 USA • (336) 245-6400 • Fax (336) 245-6453 • (888) 845-9800 • www.beverage-air.com

Specifications are subject to change without prior notice. 01/14