

A Series Sandwich & Salad Prep Table

MODEL #178APT27

REFRIGERATION
AVANTCO

www.AvantcoRefrigeration.com

A SERIES - SANDWICH & SALAD PREP TABLE

Add prep space and cold ingredient storage.

CABINET CONSTRUCTION

Features 430 type stainless steel exterior and painted aluminum interior. Overall working height is 35 $\frac{1}{4}$ ".

Foamed-in-place CFC- and HCFC-free polyurethane insulation enhances the structural integrity of the cabinet. Insulated lid helps maintain safe product temperatures.

Full-length, 10" deep cutting board for easy prep work.

Door features easy-to-use, recessed handle for quick interior access. Door stays open past 90° for easy loading, but will self-close under 90° to save energy.

REFRIGERATION SYSTEM

Environmentally-safe R134a refrigerant. Rear-mounted condensing unit positioned for easy maintenance.

SHELVING

1 epoxy-coated wire shelf included. It accommodates up to 90 lb.

MODEL FEATURES

Preprogrammed digital controller features auto-defrost function.

Top pan rail holds up to (6) $\frac{1}{6}$ size and (2) $\frac{1}{9}$ size, 6" deep food pans. Pan rail is air cooled from the bottom.

SPECIAL FEATURES

- Sleek, stainless steel exterior
- Painted aluminum interior maintains temperatures from 33-40°F
- Top holds up to (6) $\frac{1}{6}$ size and (2) $\frac{1}{9}$ size, 6" deep food pans (sold separately)
- Full length, 10" deep cutting board
- Insulated lid helps maintain safe product temperatures
- Single self-closing swing door with recessed handles
- 115V, $\frac{1}{4}$ hp, R-134a refrigerant



WARRANTY

RESIDENTIAL: Avantco assumes no liability for parts or labor coverage for component failure, factory defect or any other damages for units installed in non-commercial foodservice or residential applications.



Parts & Labor



Compressor



A Series Sandwich & Salad Prep Table



www.AvantcoRefrigeration.com

MODELS #178APT27

TECHNICAL DATA

Dimensions

Exterior Dimensions	27½"W x 31"D x 42⅜"H
Interior Dimensions	24"W x 23¾"D x 23½"H
Working Height	35¼"
Cutting Board Dimensions	27¼"W x 10"D x ¾"H
Net Volume	6 cu. ft.
Net Weight	176 lb.
Gross Weight	231 lb.
Pan Capacity	(6) ⅙ + (2) ⅓
Packing Dimensions	31¾"W x 33¾"D x 45½"H

Cooling

Temperature Range	33°F - 40°F
Refrigerant	R134A
Max. Ambient Temperature	90°F
Defrosting	Automatic
Temperature Controller	Digital
Horsepower	1/4

Construction

Exterior Material	Type 430 Stainless Steel
Interior Material	Painted Aluminum
Insulation Material	Foamed-in-place Polyurethane
Shelves	(1) 17¼"W x 23½"D
Shelf Material	Epoxy-coated Steel
Shelf Load Capacity	90 lb.

Electrical

Voltage	115
Amps	5.3
Hz	60
Phase	1
Plug Type	NEMA 5-15P
Electrical Cord Length	84"

PLAN VIEW

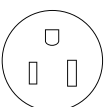
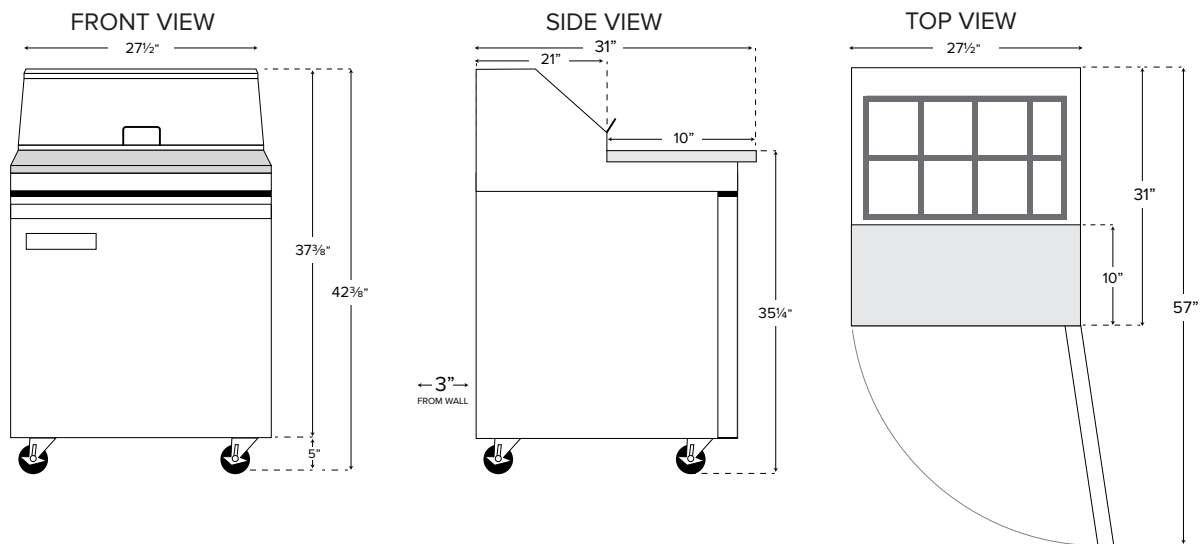

NEMA 5-15P