



Full Size Electric Countertop Food Warmer/ Topping Station

ITEM NUMBER

#177WK12007P

SPECIAL FEATURES

- Conveniently offer two sauces or toppings from one unit
- Maintains food safe temperatures for hours
- Stainless steel water well with level markings
- Includes a steam table adapter, (2) 7 qt. insets, and 2 condiment pumps
- Standard 1200W heating element; 120V

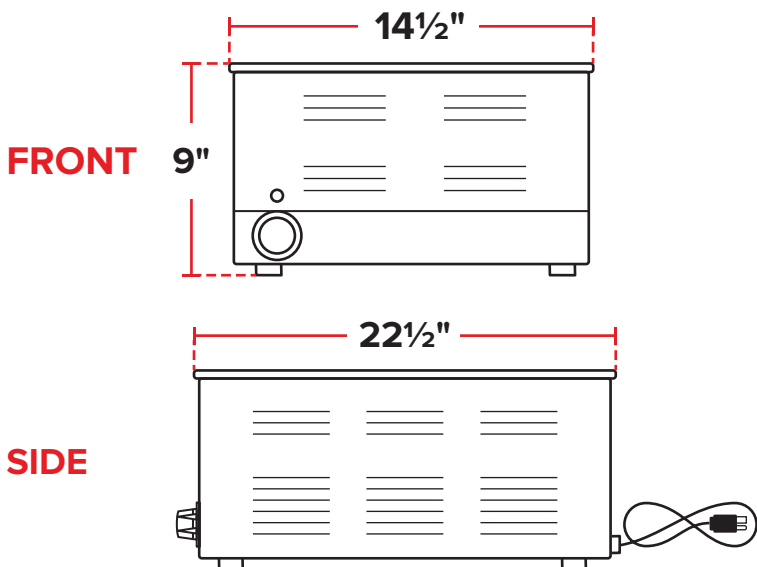

TECHNICAL DATA

Interior Dimensions	12" x 20" x 6¼"
Exterior Dimensions	14½" x 22½" x 9"
Temperature Range	120-165°F
Voltage	120V
Wattage	1200W
Hertz	60Hz
Amps	10 Amps
Phase	1
Material	Stainless Steel



5-15P