



# Full Size Electric Countertop Food Warmer

## ITEM NUMBER

#177WK120047

## SPECIAL FEATURES

- Maintains foodsafe temperatures for hours
- Stainless steel water well with leveling marks
- Powerful 1200W heating elements
- Includes a steam table adapter, (1) 7 qt. inset, (1) 4 qt. inset, 2 ladles, and 2 lids

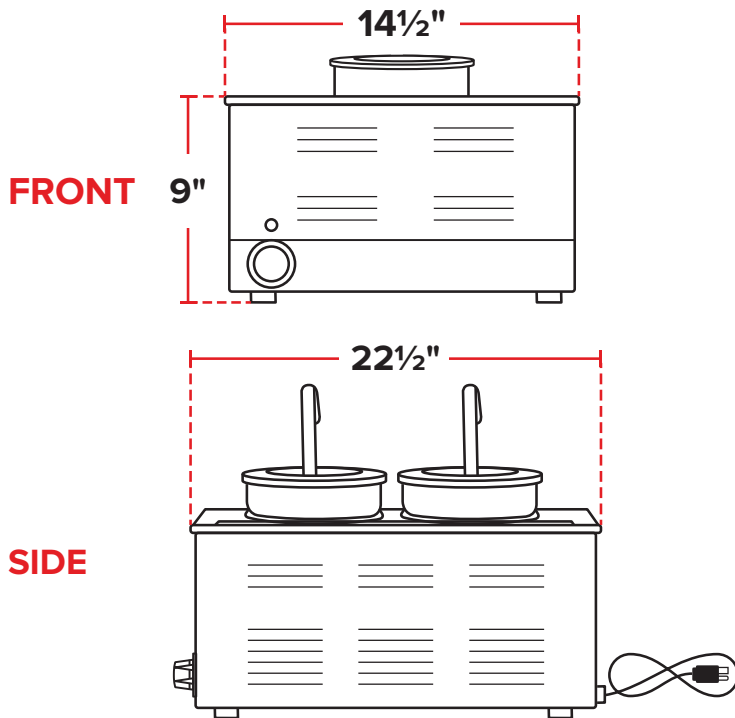

## TECHNICAL DATA

Interior Dimensions	12" x 20" x 6 1/4"
Exterior Dimensions	14 1/2" x 22 1/2" x 9"
Temperature Range	140° F
Voltage	120V
Wattage	1200W
Hertz	60Hz
Amps	10 Amps
Phase	1
Material	Stainless Steel



**5-15P**