



Full Size Electric Countertop Food Warmer/ Topping Station

ITEM NUMBER

#177WK12002X6

SPECIAL FEATURES

- Includes 6 hole adapter, (6) 2½ Qt. Inset pots, (6) notched covers, and (6) 1 oz. ladles
- Heavy-duty water well
- Heating element supports direct heat to food using water
- 27 qt. well capacity; 15 qt. inset capacity
- 120V, 1200W

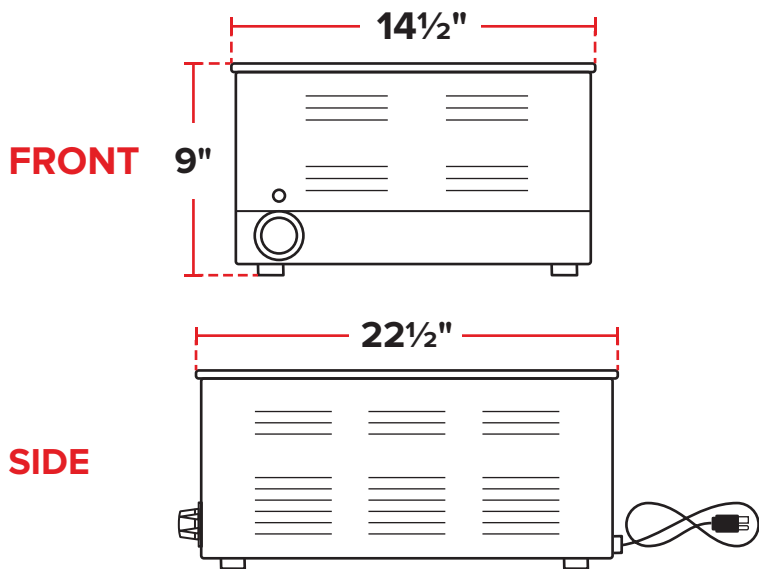

TECHNICAL DATA

Interior Dimensions	12" x 20" x 6¼"
Exterior Dimensions	14½" x 22½" x 9"
Temperature Range	120-165°F
Voltage	120V
Wattage	1200W
Hertz	60Hz
Amps	10 Amps
Phase	1
Material	Stainless Steel



5-15P