



## 65" Countertop Vertical Band Meat Saw

### ITEM NUMBER

#177EMBS65SS

### SPECIAL FEATURES

- Features a powerful 1hp motor with a 50 ft. per second cutting speed
- Optimal for heavy-duty use, with a full stainless steel chassis, head, and work table
- Includes a sharp 65" long blade with 3 teeth per inch and maximum cutting dimensions of 8" x 7"
- This countertop model is intuitive to operate to make precise cuts on meats like beef or lamb
- Built with a safety shut-off switch and blade guard

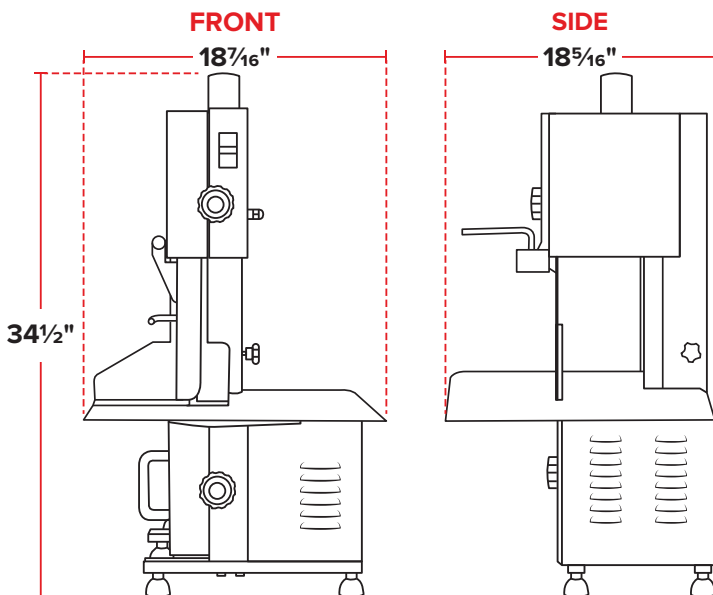

### TECHNICAL DATA

<b>Dimensions</b>	18 <sup>7</sup> / <sub>16</sub> " x 18 <sup>5</sup> / <sub>16</sub> " x 34 <sup>1</sup> / <sub>2</sub> "
<b>Cutting Clearance Width</b>	7"
<b>Cutting Clearance Height</b>	8"
<b>Phase</b>	1
<b>Blade Size</b>	65"
<b>Voltage</b>	120V
<b>Cutting Speed</b>	50 Feet Per Second
<b>Horsepower</b>	1hp
<b>Type</b>	Band Saws



**5-15P**