



Service Manual – Seraphim Coffee Brewer

Important Safeguards/Symbols

This equipment is designed for commercial use. Any servicing other than cleaning and routine maintenance should be performed by an authorized Wilbur Curtis Co., Inc. service technician.

- DO NOT immerse the unit in water or any other liquid.
- To reduce the risk of fire or electric shock, DO NOT open service panels. There are no user serviceable parts inside.
- Keep hands and other items away from hot areas of the unit during operation.
- Never clean with scouring powders or harsh chemicals.

Symbols:



WARNING/CAUTION – To advise about conditions that may result in property damage, personal injury or death



IMPORTANT – Notes about proper operation



NSF Sanitation requirements

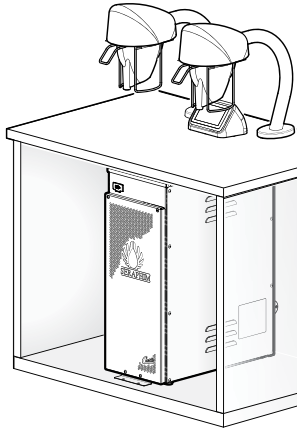

Models:

- SERA2B, SERA2W,
- SERA2W330033,
- SERA2B330033,
- SERA2B30,
- SERA2W30,
- SERA2B33,
- SERA2W33,
- SERA2B300293,
- SERA2W300293

The Curtis G4 brewer is preset at the factory for optimal performance.

Following are the factory settings for the G4 Coffee Brewing System:

- Brew Temperature = 200°F
- Brew Volume = Set to vessel requirement.

System Requirements:

- Water Source 20 – 90 psi (138 – 620 kPA) with a minimum flow rate of 2 gpm (7.5 lpm).



NOTE: A water filtration system must be used to help maintain trouble-free operation. **Air must be purged from the cartridge prior to connection to equipment.** In areas with extremely hard water, we highly recommend the use of a Curtis approved water filter. For our full line of filters, please visit www.wilburcurtis.com.

- Electrical: See attached schematic for standard model or visit www.wilburcurtis.com for your model.



NOTE: Electrical source should have a minimum 30 A internal common trip circuit breaker between the brewer and the main supply, which breaks all poles with a contact separation of at least 3 mm.



NSF International requires the following water connection:

1. A quick disconnect or additional coiled tubing (at least 2x the depth of the unit) is required so that the unit can be moved for cleaning.
2. This brewer must be installed with adequate back-flow protection to comply with applicable federal, state and local codes.
3. Water pipe connections and fixtures directly connected to a potable water supply shall be sized, installed and maintained in accordance with federal, state and local codes.

CAUTION: Use this setup procedure before attempting to use this brewer. Failure to follow the instructions can result in personal injury or void the warranty.

IMPORTANT: Equipment to be installed to comply with applicable governmental plumbing/electrical codes having jurisdiction.

CAUTION: DO NOT connect this brewer to hot water. The inlet valve is not rated for hot water.

INSTALLATION INSTRUCTIONS

CAUTION: Avoid Injury. Do not turn on water or electricity until the brew head and water tower assemblies are properly installed.

Please adhere to these installation instructions to ensure proper set up.

Confirm that the planned location for the coffee brewer has the proper electric and water supply. In addition, water drain pipes and the floor stability should be considered.

The water tower should be installed and grounded properly by a qualified installer or service technician. This unit must be electrically grounded in accordance with local codes.

Carefully unpack the Seraphim brewer components from the shipping crates.

continued...

ISO 9001:2008 REGISTERED

WILBUR CURTIS CO., INC.
 6913 Acco Street
 Montebello, CA 90640-5403
 For the latest information go to
www.wilburcurtis.com
 Tel: 800-421-6150
 Fax: 323-837-2410

STEP 1. BEFORE INSTALLATION – PREPARE THE COUNTER TOP

Holes must be cut into the counter top prior to installing the brewer. The hole pattern is critical for proper operation of the Seraphim coffee brewer. See Figure 2 below for the basic counter layout. The two brew heads must fit within a 2 foot by 3 foot area.

Packed with the unit is a full-size template (Part № WC-390245). Use the template for cutting the required holes needed for installing the brew heads, touchscreen and drip tray. The two largest circular holes are for the brew head assemblies, along with three stud holes for the mounting plate for each head. Also, there is a circular hole for the touch screen, along with the two mounting holes. The drip tray can be inset into the counter or mounted flush. Inset installation is recommended. The rectangular hole shown below is for inset installation. If the drip tray will be mounted flush, a circular hole is drilled in the location shown for the drain instead of a rectangular hole.

Consideration must be made for the drip tray drain system. The drip tray comes with a 1/2" NPT X 3" nipple for connecting the drain system (supplied by the purchaser) to the drain fitting located on the bottom of the drip tray. See Figure 3 on the facing page for dimensions.

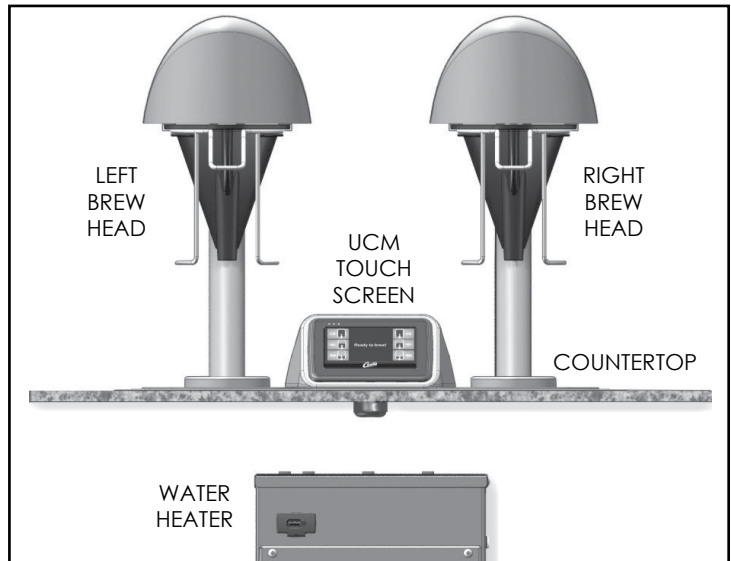

Figure 1 - Cabinet Installation Showing Four Main Sections of Seraphim Brewing System

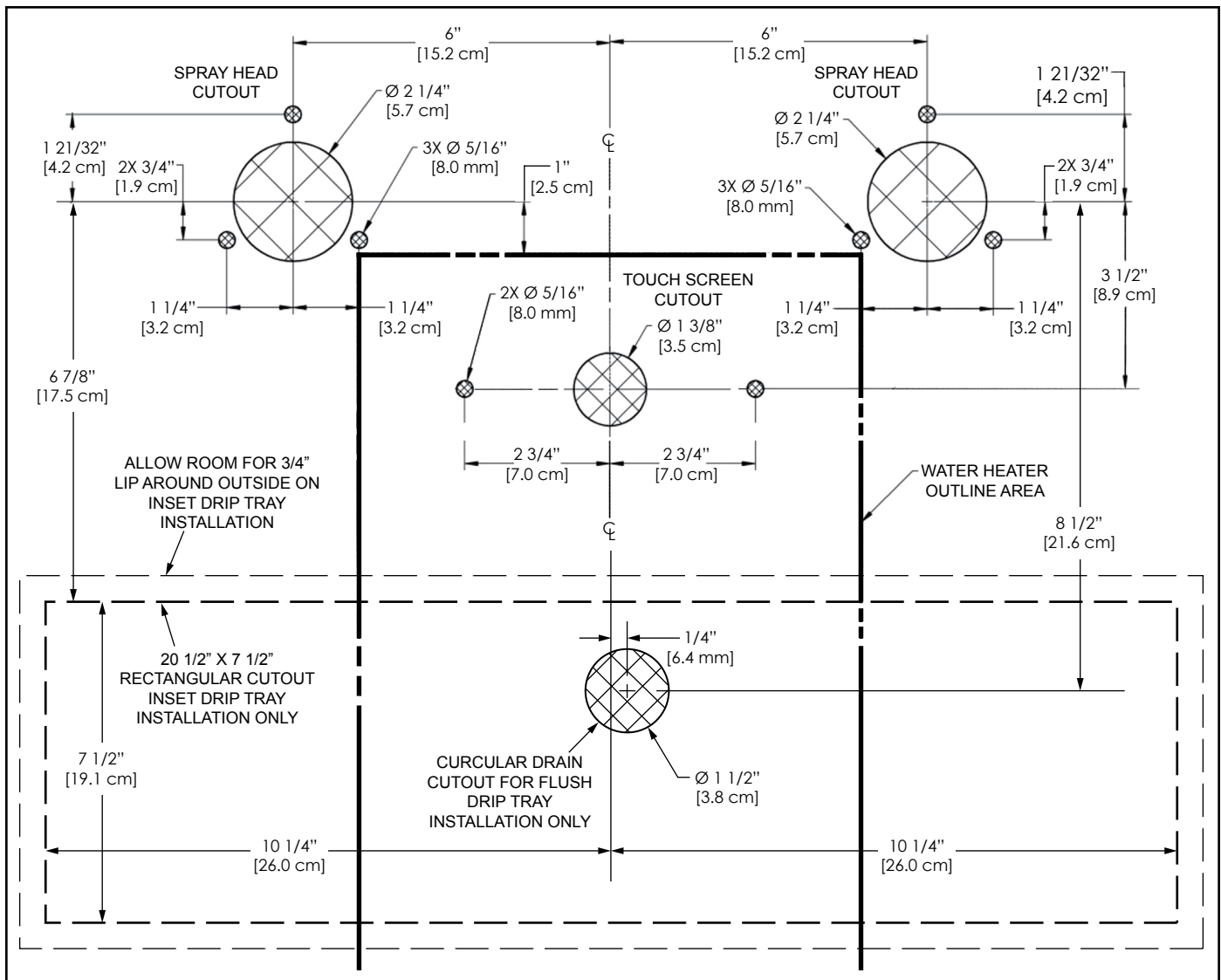

Figure 2 - Hole Pattern Template for Cutting and Drilling Counter Top (Drawing Not to Scale)

STEP 2. INSTALL THE DRIP TRAY

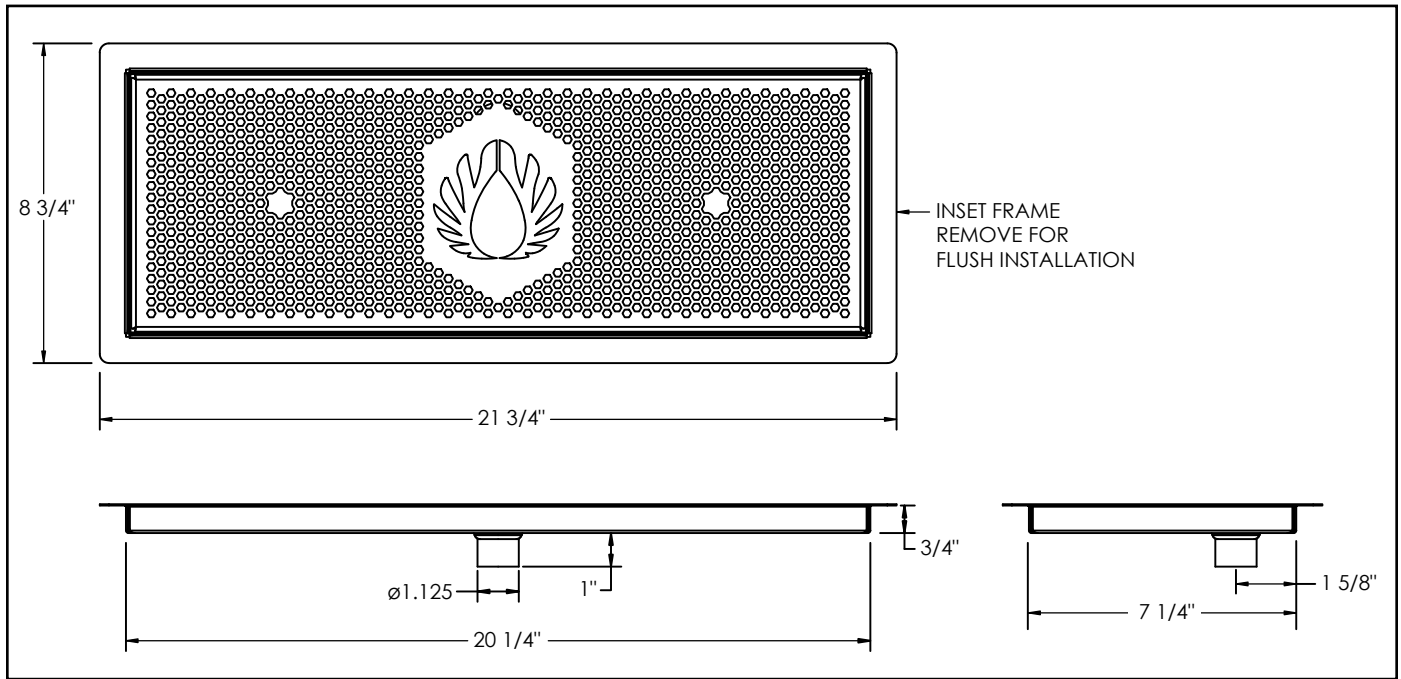

Figure 3 - Drip Tray Dimensions

After preparing the drip tray location, according to Step 1, apply Teflon plumbing tape to the threads on the supplied pipe nipple and thread into the bottom of the drip tray. Assemble the drip tray pieces as shown in Figure 4 and place them into position. Install the drain system.

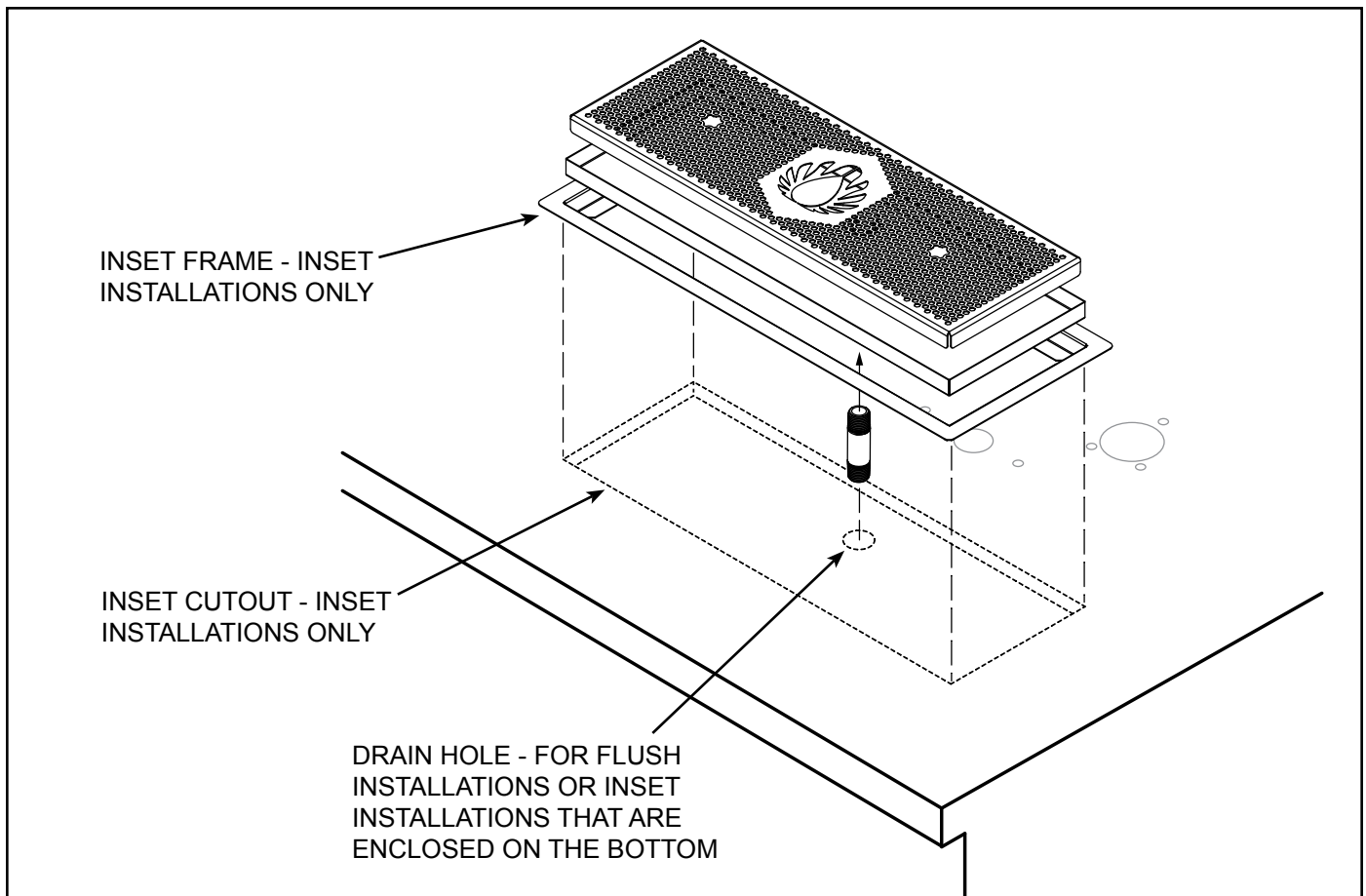

Figure 4 - Drip Tray Installation

STEP 3. INSTALL THE BREW HEAD



CAUTION: Do not open the brew head units! The length of the wires and tubing are fixed and set at the factory. Do not splice or extend the tubes that come from beneath the brew head assembly. Ample tube length is provided and the tubes will need to be shortened in most cases for proper installation.

Install the brew head units into the counter top in the correct position. One brew head is designed to be installed on the right side and the other on the left. The installation position for each brew head is marked on the attached wires and tubes. Each brew head has three 1/4–20 studs with matching nuts and washers for mounting onto the surface of the counter. Hold a brew head over the group of holes that matches the markings on the brew head tubing/wiring (right or left). Insert the tubes and wires into the large center hole and insert the studs through the three smaller holes, while pushing the unit down onto the counter top. Secure with the nuts supplied. Repeat for the other brew head.

STEP 4. INSTALL THE UCM ASSEMBLY

Locate the wiring harness and UCM plugs coming from behind the water tower. Plug the touch screen wiring harness and USB wiring into the receptacles in back of the UCM. These will snap and lock into place. Install the UCM/holder onto the counter top. Slip the two 1/4–20 threaded studs into the counter top and fasten the holder to the Counter using (1) fender washer, (1) lock washer and (1) nut per threaded stud. Once the touchscreen and the brew head assemblies are properly installed in the counter top, proceed to the next step.

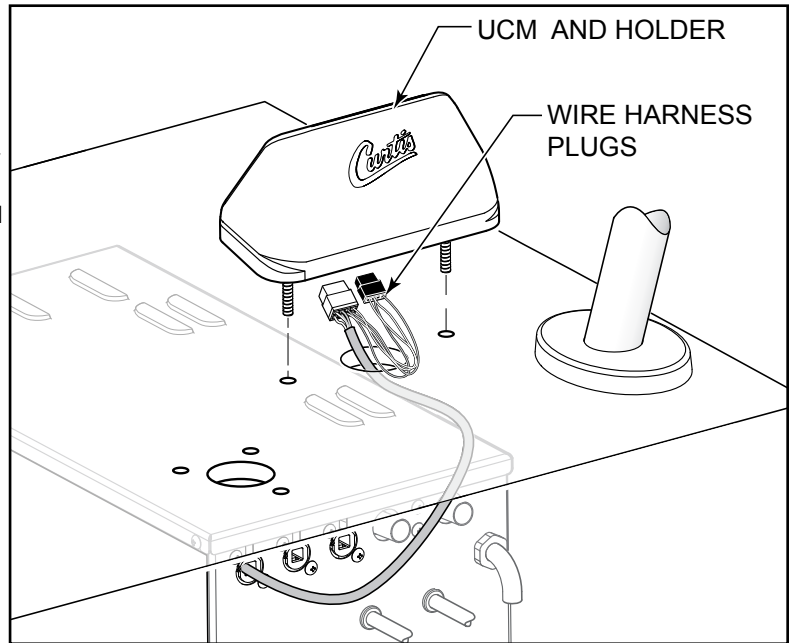

Figure 5 - UCM Assembly and Harness Plugs

STEP 5. INSTALL THE WATER TOWER

Remove the water tower top cover (two screws) and side cover. Remove the screws from the cable support plates, attached to the control cables coming from the brew heads. Insert the cable support plates into the chassis and run the cables through the holes in the back of the chassis (see Figure 6.1). The cables for the right and left brew heads route through the two cable ports on the right. The left port is for the UCM controller cable.

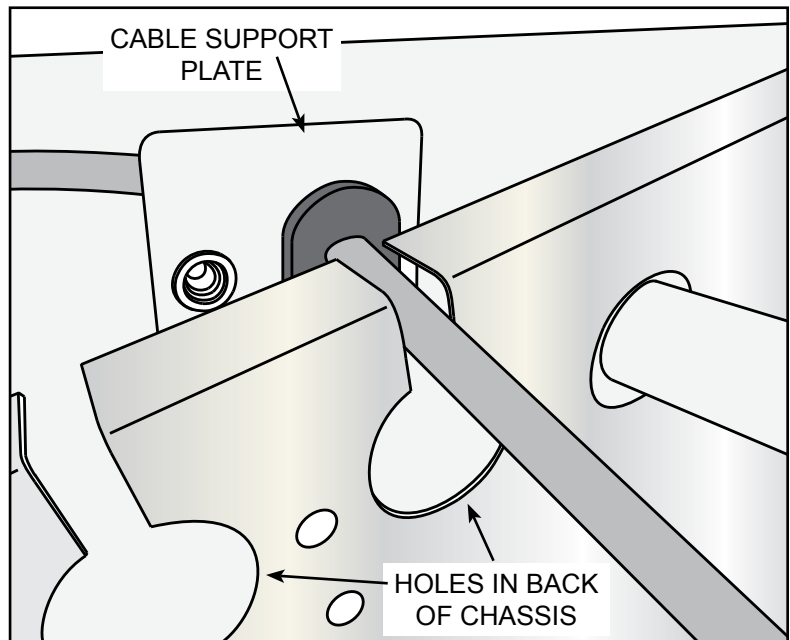

Figure 6.1 - Brew Head Cable and Cable Support Plate

Use the screws to attach the plates to the chassis as shown in Figure 6.2 (back view).

Connect the brew head cables to the connectors inside the chassis. The connectors are labeled right and left to indicate the correct cable connection.

Replace the water tower top cover and side cover.

We recommend attaching the power cord and plug to the unit first before placing the water tower into the cabinet beneath the counter. Make sure power to the circuit supplying power to the unit is turned off at the circuit breaker panel until installation is complete.

With the brew heads installed, place the water tower on the floor of the cabinet below the counter top. Center it between the two heads. Refer to the hole pattern drawing (Figure 2) for the proper location of the water tower. The water tower should be level (left to right and front to back), on a secure surface. Wait to install the hold down brackets until instructed to do so.

Connect the water line to the water inlet fitting at the rear of the unit. The water flow to the machine should be consistent. Use tubing sized sufficiently to provide a minimum flow rate of two gallons per minute.

Brew Head Water Return Lines

Link the brew heads to the water tower by attaching the water return lines. These are the two larger diameter flexible silicone tubes that come from behind the water tower. The matching return lines from the spray head assemblies will have a straight fitting slipped into the end of the tube. Join the return line tubes together using this fitting. Make sure they are correctly oriented as shown in Figures 7 and 8.



CAUTION: The water return lines must not sag. Route them in a downhill orientation between the bottom of the brew head assemblies and the back of the water tower (see Figure 8). The tubing can be shortened if necessary to make sure that the lines are free of sag that will trap water inside them between the brew heads and the water tower.

Brew Head Water Supply Lines

Behind the water tower, there are two 1/4 inch diameter water supply lines. The water supply line tubing should be shortened to minimize length when connected with the matching 1/4 inch tubing coming from the bottom of the brew head assemblies. There are straight barbed fitting connectors already inserted into the tubes from the head unit. To make the connection between the two tubes, insert the tube from the back of the water tower into the supply line tube fitting from the brew head assembly.

continued...

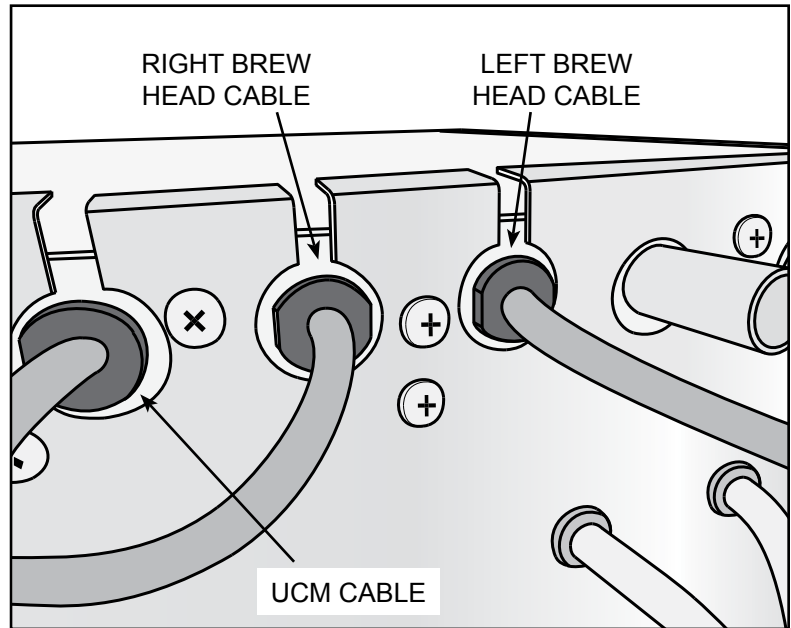

Figure 6.2 - Harness Cable Locations

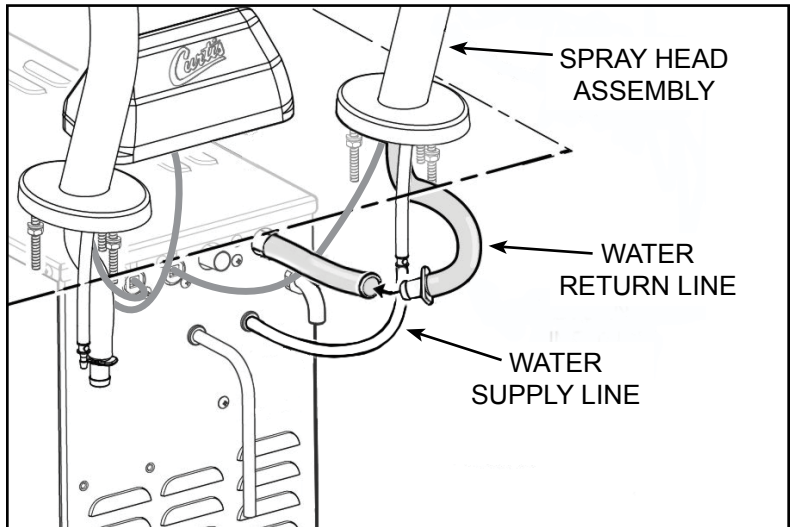

Figure 7 - Hook-up Water Supply and Return Lines

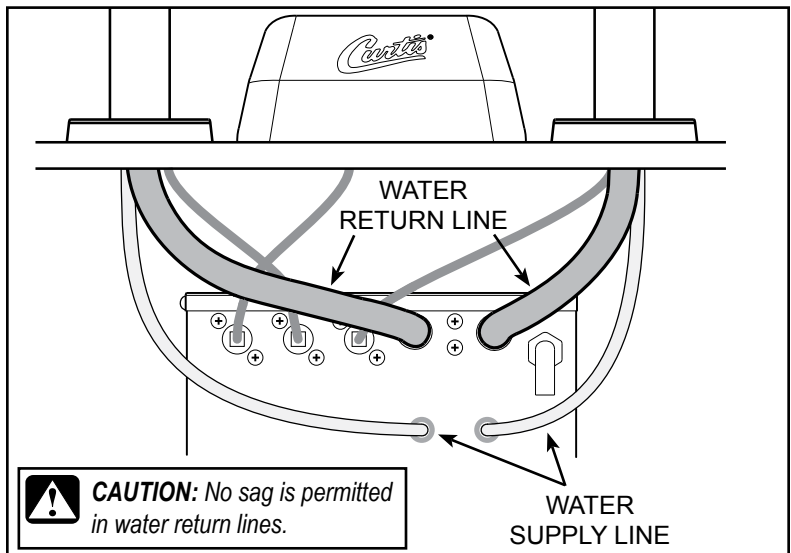

Figure 8 - Back View Showing Supply and Return Line Routing

Exhaust Lines

The water tower is equipped with two outlet fittings that vent steam and condensation from the water tank inside the chassis. Run the provided exhaust line tubing from these fittings to a drain to drain off condensation.

i **IMPORTANT:** The exhaust line tubing must be installed so that ends do not become submerged in water to avoid backup.

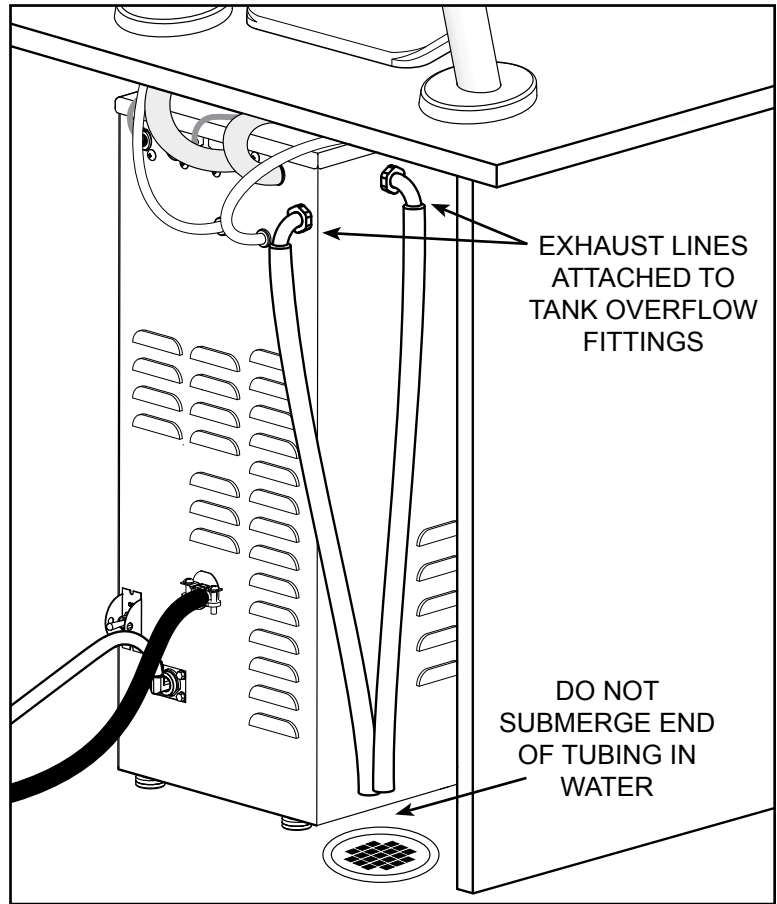

Figure 9 - Exhaust Line Installation

Hold-down Brackets

Install the hold-down brackets after mounting the brew heads and making the water and electrical hookups on the water tower.

The hold-down brackets are for positioning the water tower and to reduce the risk of tipping. The water tower must be secured to the bottom of the cabinet.

⚠ CAUTION: Failure to install the anti-tip brackets may cause the unit to tip over when installed in a mobile coffee counter. Injury might result from spilled hot liquids or damage may occur to the water tower itself.

The brackets fasten onto the floor and prevent the water tower from shifting from its predetermined position. If the brewer is ever installed in a different location, these brackets must also be moved and installed with the water tower. The hold-down brackets are affixed to the bottom edge of the water tower. One on the front and one on the side.

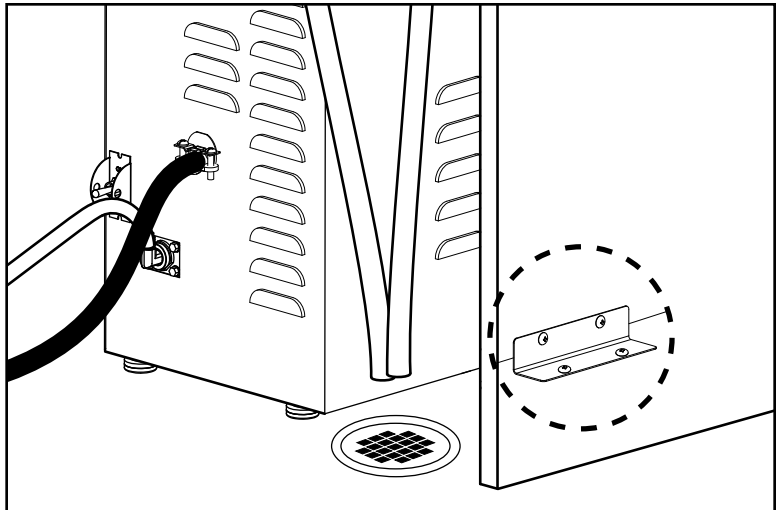

Figure 10 - Hold-Down Bracket

STEP 6. TURN ON THE BREWER

Once the brew heads and the UCM are correctly mounted on the counter top and the water tower is properly installed, turn on the water supply at the water source. After turning on the water, plug in the power cord. Connect the unit to an electrical circuit with an appropriate amperage rating; refer to the serial tag on the machine and local/national electrical codes to determine circuit requirements. Turn on power to the circuit supplying power to the unit at the circuit breaker panel. Turn the toggle switch on the back of the water tower to the ON position. The water tank will start to fill. Once filled, the heating elements will come on. It will take about 45 minutes for the temperature to reach 200°F. You are now ready to brew.

QUICK START

Your Curtis G4/Gold Cup Series Brewer is factory preset for optimal performance.

After connection to water and power; turn on the brewer at the rear toggle switch. You will hear a beep and the status lights will come on for a moment.

The screen will display MODEL NUMBER
CONTROL BD NUMBER. Next FILLING is displayed. Water will fill the tank (3-5 minutes depending on water flow rate).

When the proper level is reached HEATING will appear on the screen. It takes approximately 45 minutes to reach the set point temperature.

The screen will display READY TO BREW when temperature reaches the set point. The unit is now ready to brew.

COFFEE BREWING INSTRUCTIONS

1. Brewer should be ON. Confirm this at the toggle switch on the back of the water tower, at the lower right side. The touch-screen should read Ready to brew.
2. Center an empty coffee container beneath the brew head.



WARNING – TO AVOID SCALDING, AVOID SPLASHING. Do not remove the brew basket while Brewing... appears on the display.

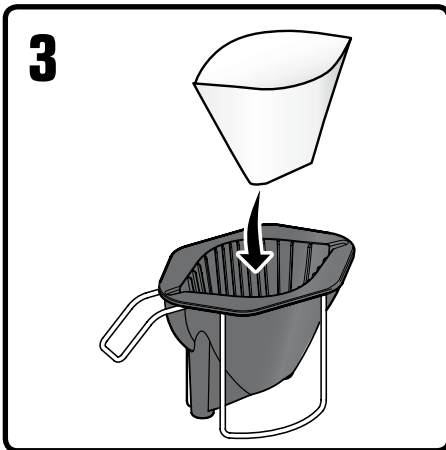

3. Place a clean filter into the brew basket.

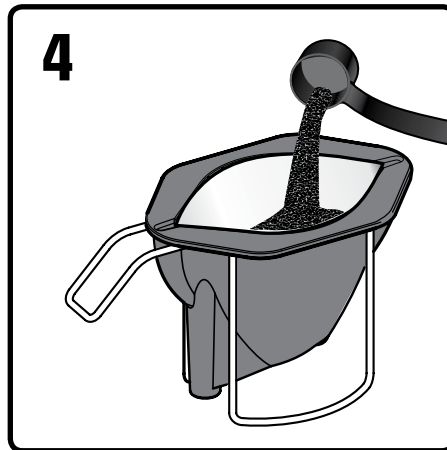

4. Fill the filter with the proper amount of ground coffee.

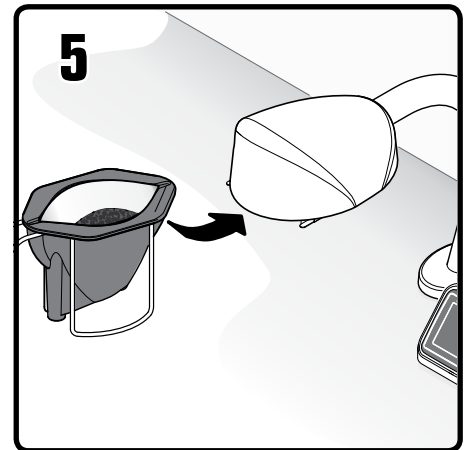

5. Slide the filled brew basket into the brew rails on the brew head.

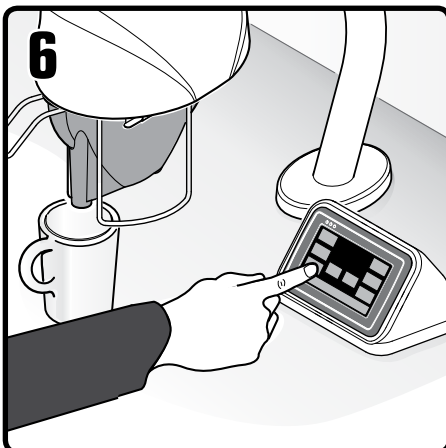

6. Start the brew cycle by holding your finger on the desired brew icon. As soon as you hear the click of the brew valve, the brew cycle has started and you can lift your finger.



Brew Code: When a brew button is pressed, a keypad may appear on the screen. This is the brew lock-out feature. When this keypad appears, you must enter a code to continue.

CAUTION: As soon as you enter the brew code, brewing will start.

The default is OFF. See page 8 to enable, disable and set the brew code.



During the brew cycle, a coffee cup icon will appear on the screen and a brew timer will count down the time remaining for the brew cycle.

Touchscreen Control Module

The touch screen turns on whenever power is provided to the brewer and the rear toggle switch is on. The symbol buttons on the screen control operation and programming. Pressing the on-screen symbols and buttons with your finger tip activates the various functions. The default screen, as well as additional control buttons are shown below.

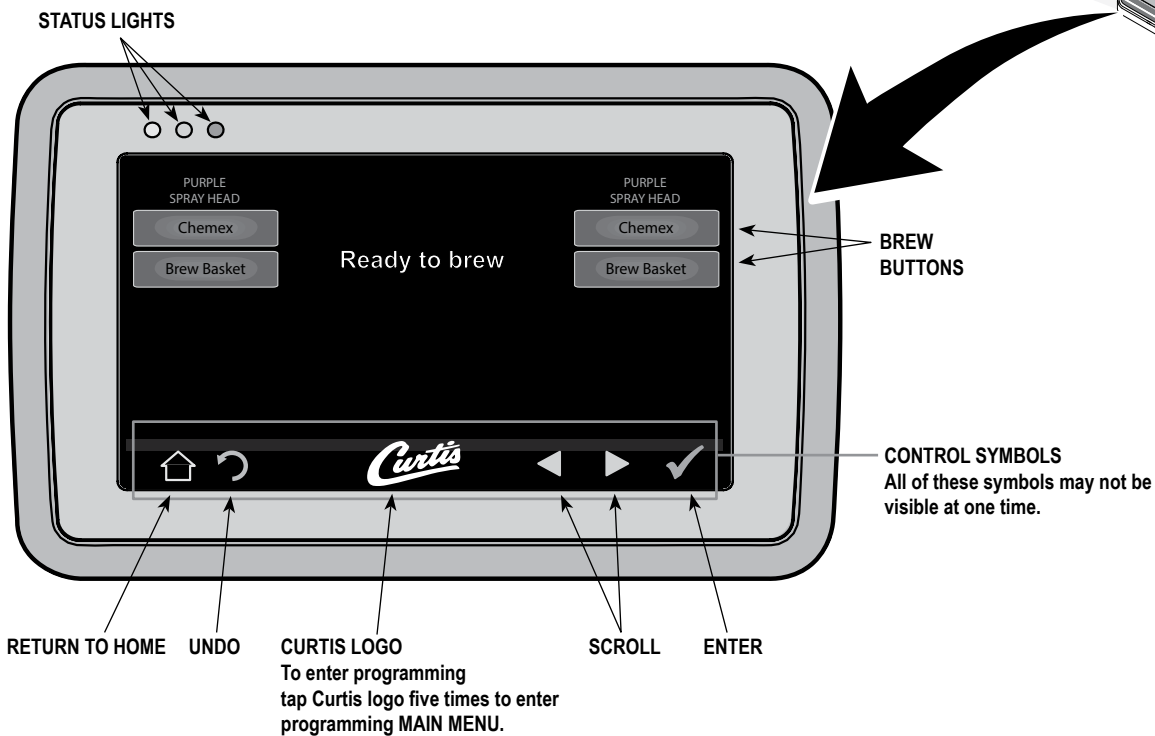

Programming

ENTER ACCESS CODE		
1234		
1	2	3
4	5	6
7	8	9
Del	0	OK

ACCESS CODE screen. Default is 1 2 3 4. Once the code is entered, press OK. The MAIN MENU screen will appear.

The access code can be reset in Control Settings, Passwords.

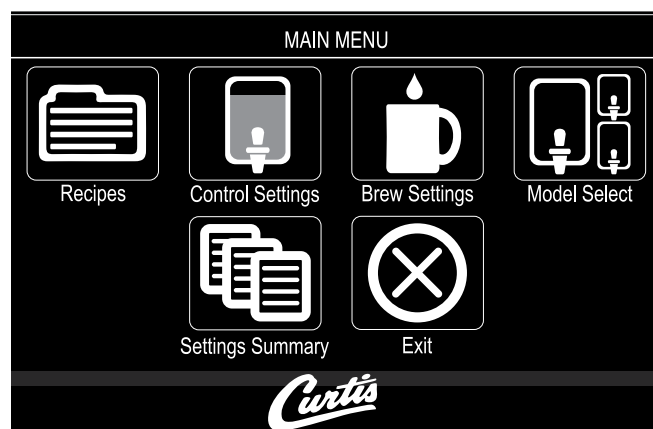

MAIN MENU screen contains six control icons: Recipes, Control Settings, Brew Settings, Model Select, Settings Summary and Exit.

Menu Tree

This chart explains how to enter programming mode and the menu selections available from the MAIN MENU.

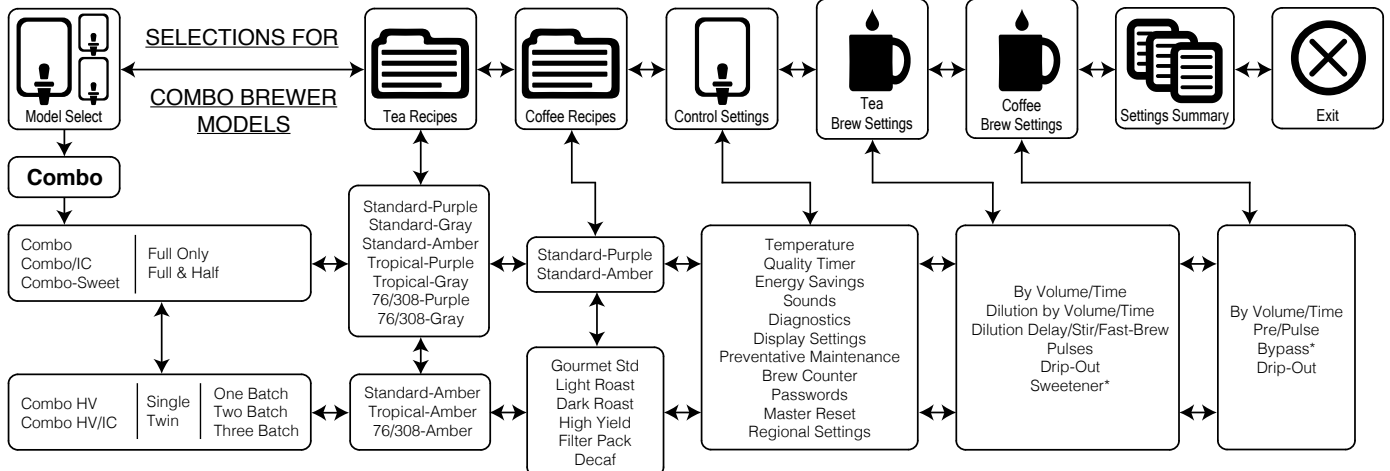
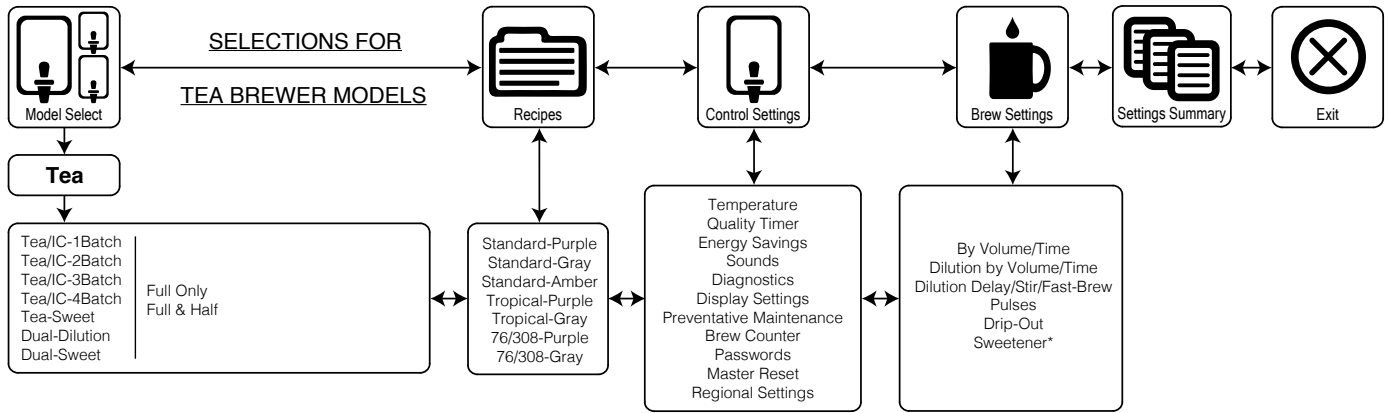
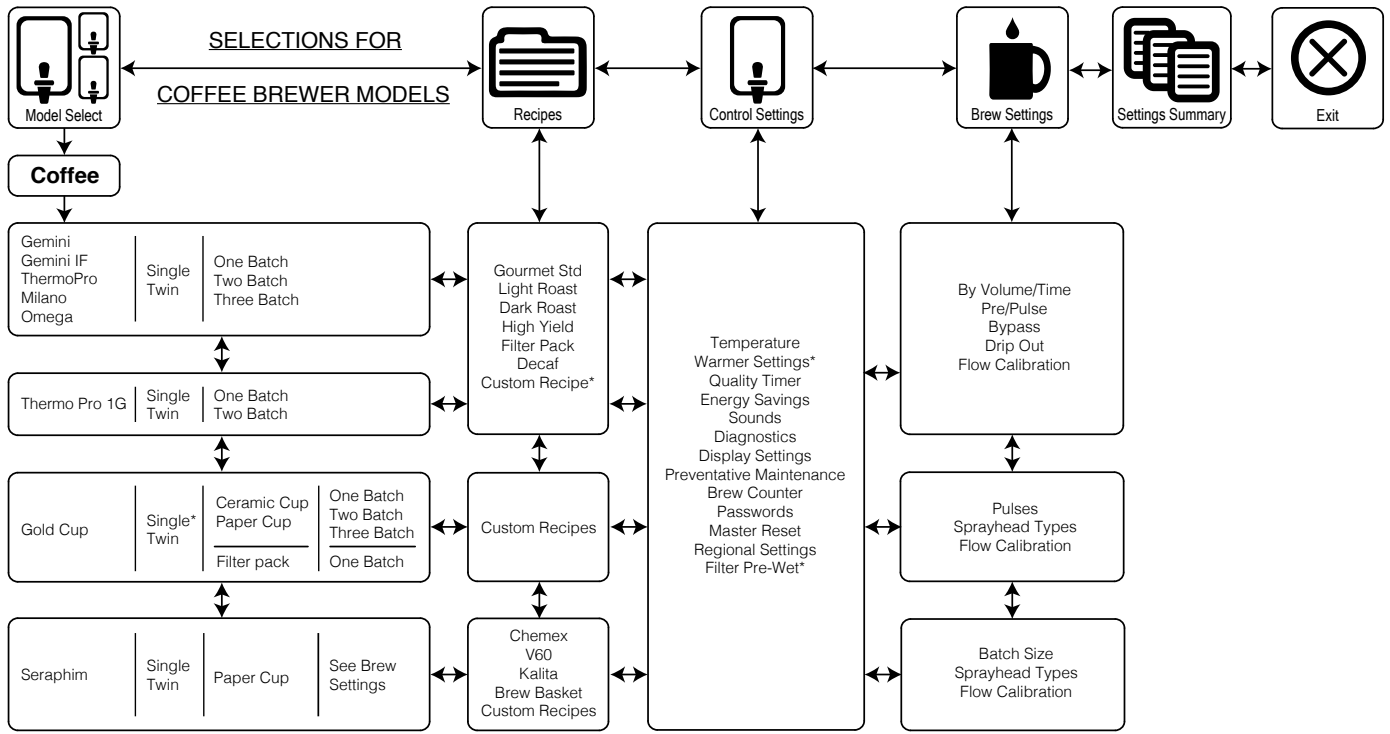

Menu Features

CONTROL SETTINGS

FUNCTION TO SET	SETTING RANGE	FACTORY SET DEFAULT	NOTES / COMMENTS
Temperature Settings	175°F - 206°F , 1°F Increments	Tank Temp = 200°F	
		Minimum Brew Temp = 185°F	
Filter Pre-Wet Time	Disabled/Enabled, 1 Second - 20 seconds, 1 Second Increments.	Disabled	Enabled = Default is 4 Seconds
Energy Save Mode (Activates after 4 Hours of Inactivity)	No Change	No Change	Tank temperature is maintained at the temp set point default
	Turn Tank Heater Off		Tank is turned off.
	Reduce tank temp to: 140°F		Tank temperature maintained at 140F.
Sounds	Beeper On/Off	On	Turns Board sounds Off or On
Diagnostics	-	Auto Test	Runs Diagnostic Tests
Display Settings	Brew Timer-Hide/Show	Show	Displays Brew Time
	Quality Timer Hide/Show	Show	Displays Quality Timer
	Icon <Original or Square Blue>	Original	Square Blue or Original
	Screen Saver	Off	Displays Screen Saver
	Display Name	Blank	Displays Banner Name
Prev. Maintenance	Maintenance Interval	Disabled	Off, 100 to 3000 Gallons, 100 Increments
	Service Telephone Number	1-800-000-0000 x0000	
Brew Counter	Resettable	Resettable	For maintenance purpose
Passwords	Programming	1234	Reprogrammable; allows access to programming screens
	Brew (Enabled/Disabled)	Disabled	Reprogrammable; allows access to brewing screens
Master Reset	Reset	Are you sure? (Yes / No)	Select to Reset to Restore Factory Defaults
Regional Settings	SI/US	US	US Units or Metric Units
	Language	English	Allows the user to select multiple languages
Home	-	-	Select to go to Home Page

Menu Features

Default Recipe Brew Button Settings (Paper Cup)

CHEMEX 24 oz													
Pulse	1	2	3	4	5	6	7	8	9	10	11	12	Total
On	8	13	8	5	5	5	3	13					1:00
oz	3.2	5.2	8.2	2	2	2	1.2	5.2					24
Off	30	10	20	20	10	10	10	0					1:50
Spray Head	Purple												
												Brew Volume	24 oz
												Total Brew Time	3:50
												Drip-out	1:00

CHEMEX 14 oz													
Pulse	1	2	3	4	5	6	7	8	9	10	11	12	Total
On	6	8	5	3	3	2	8						:35
oz	2.4	3.2	2	1.2	1.2	0.8	3.2						14
Off	30	10	20	20	20	10	0						1:50
Spray Head	Purple												
												Brew Volume	14 oz
												Total Brew Time	3:25
												Drip-out	1:00

V60 14 oz													
Pulse	1	2	3	4	5	6	7	8	9	10	11	12	Total
On	6	8	5	5	3	3	8						:38
oz	2.2	2.96	1.85	1.85	1.11	1.11	2.96						14.1
Off	30	10	20	20	10	10	0						1:40
Spray Head	Gray												
												Brew Volume	14.1 oz
												Total Brew Time	3:18
												Drip-out	1:00

V60 12 oz													
Pulse	1	2	3	4	5	6	7	8	9	10	11	12	Total
On	6	8	5	5	3	3	2						:32
oz	2.2	2.96	1.85	1.85	1.11	1.11	0.74						11.8
Off	30	10	20	20	10	10	0						1:40
Spray Head	Gray												
												Brew Volume	11.8 oz
												Total Brew Time	3:12
												Drip-out	1:00

KALITA 24 oz													
Pulse	1	2	3	4	5	6	7	8	9	10	11	12	Total
On	6	13	8	8	5	5	7	13					1:05
oz	2.22	4.81	2.96	2.96	1.85	1.85	2.59	4.81					24
Off	30	10	14	14	14	14	14						1:50
Spray Head	Gray												
												Brew Volume	24 oz
												Total Brew Time	3:55
												Drip-out	1:00

KALITA 14 oz													
Pulse	1	2	3	4	5	6	7	8	9	10	11	12	Total
On	6	13	8	5	3	3							:38
oz	2.22	4.81	2.96	1.85	1.11	1.11							14.1
Off	30	20	20	20	20								1:50
Spray Head	Gray												
												Brew Volume	14.1 oz
												Total Brew Time	3:28
												Drip-out	1:00

BREW BASKET 24 oz													
Pulse	1	2	3	4	5	6	7	8	9	10	11	12	Total
On	8	13	8	5	5	5	3	13					1:00
oz	3.2	5.2	8.2	2	2	2	1.2	5.2					24
Off	30	10	20	20	10	10	10	0					1:50
Spray Head	Purple												
												Brew Volume	24 oz
												Total Brew Time	3:50
												Drip-out	1:00

BREW BASKET 14 oz													
Pulse	1	2	3	4	5	6	7	8	9	10	11	12	Total
On	6	8	5	3	3	2	8						:35
oz	2.4	3.2	2	1.2	1.2	0.8	3.2						14
Off	30	10	20	20	20	10	0						1:50
Spray Head	Purple												
												Brew Volume	14 oz
												Total Brew Time	3:25
												Drip-out	1:00

NOTE:
 Recipe Defaults are for Seraphim Models Only.
 Custom Recipe feature is "enabled".

System Fault Messages

WARNING MESSAGES - ALLOWS BREWING

MESSAGE DISPLAY	WARNING DESCRIPTION	CAUSE
Maintenance Required	Maintenance Required	Brew count "Gallons Since Reset" exceeds programmed Preventative Maintenance period.
Low Water Flow Warning	Low Water Flow	If the Inlet valve remains on longer than XX Seconds (during the brew cycle only) and repeats TWICE during that brew cycle. It shall clear upon the next brew and if the same low flow exists again, it will re-appear. XX = Alpha 20 secs; Gem/TP Twin 40 secs; Gem/TP Single 30 secs.
Internal Error 2	UPM-UCM have a mismatch in their settings	UPM-UCM have a mismatch in their settings, firmware update needed.

ERROR MESSAGES - STOPS BREWING

MESSAGE DISPLAY	ERROR DESCRIPTION	CAUSE
Water Level Error	Fill run error / Overflow	The water inlet valve has either been open for more than 10 minutes on the initial tank fill or has been open for 120 Seconds on Large Brewers and 30 Seconds on CGC, ALP, D60, Airpot, Tea brewers in normal operation.
Sensor Error	Open Sensor	Break in the temperature thermistor circuit or short circuit.
Internal Error 1	UPM-UCM Communication	Break in the UPM-UCM Communication circuit.

Brew Access Code

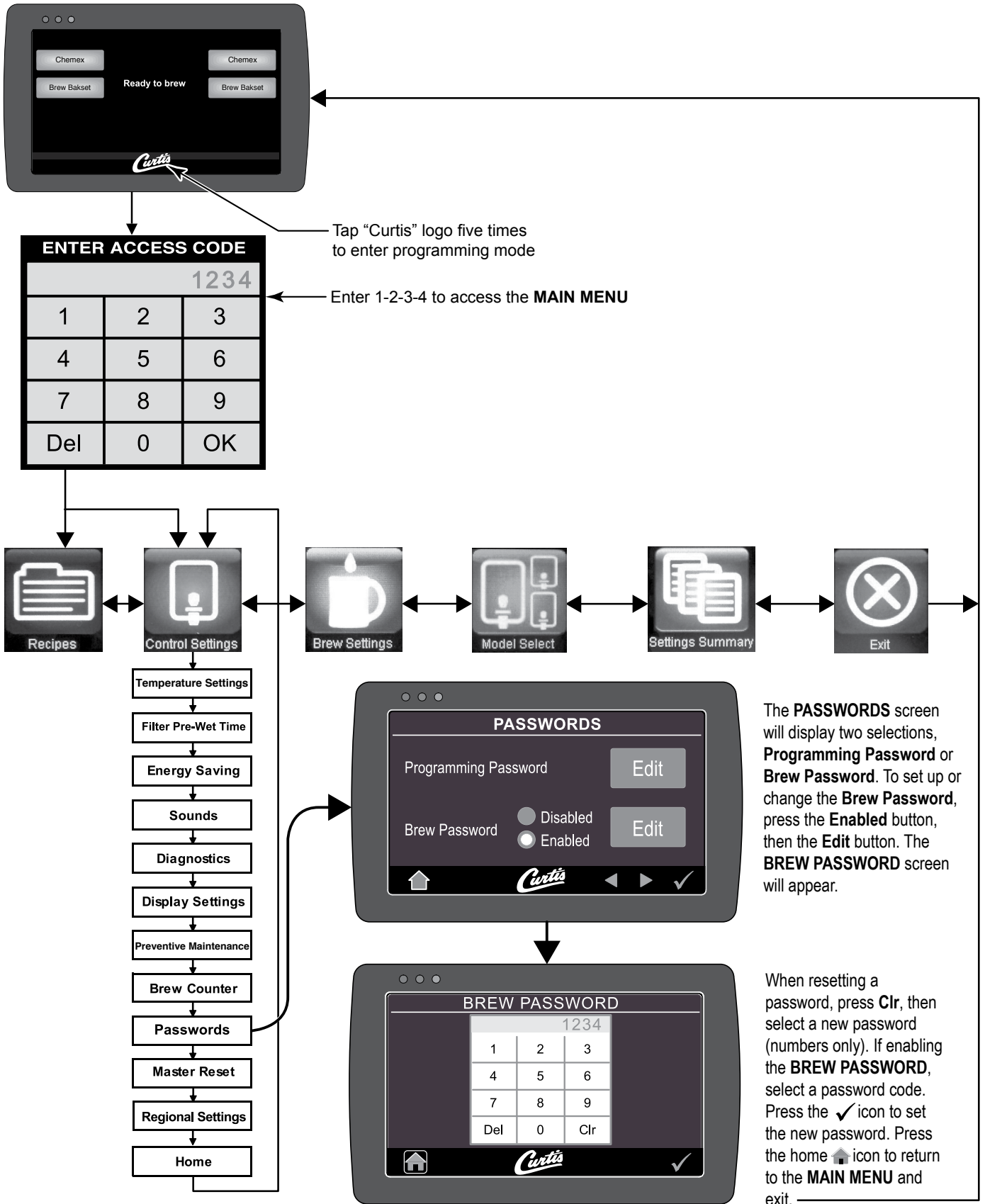

Illustrated Parts

Main View of Water Tower

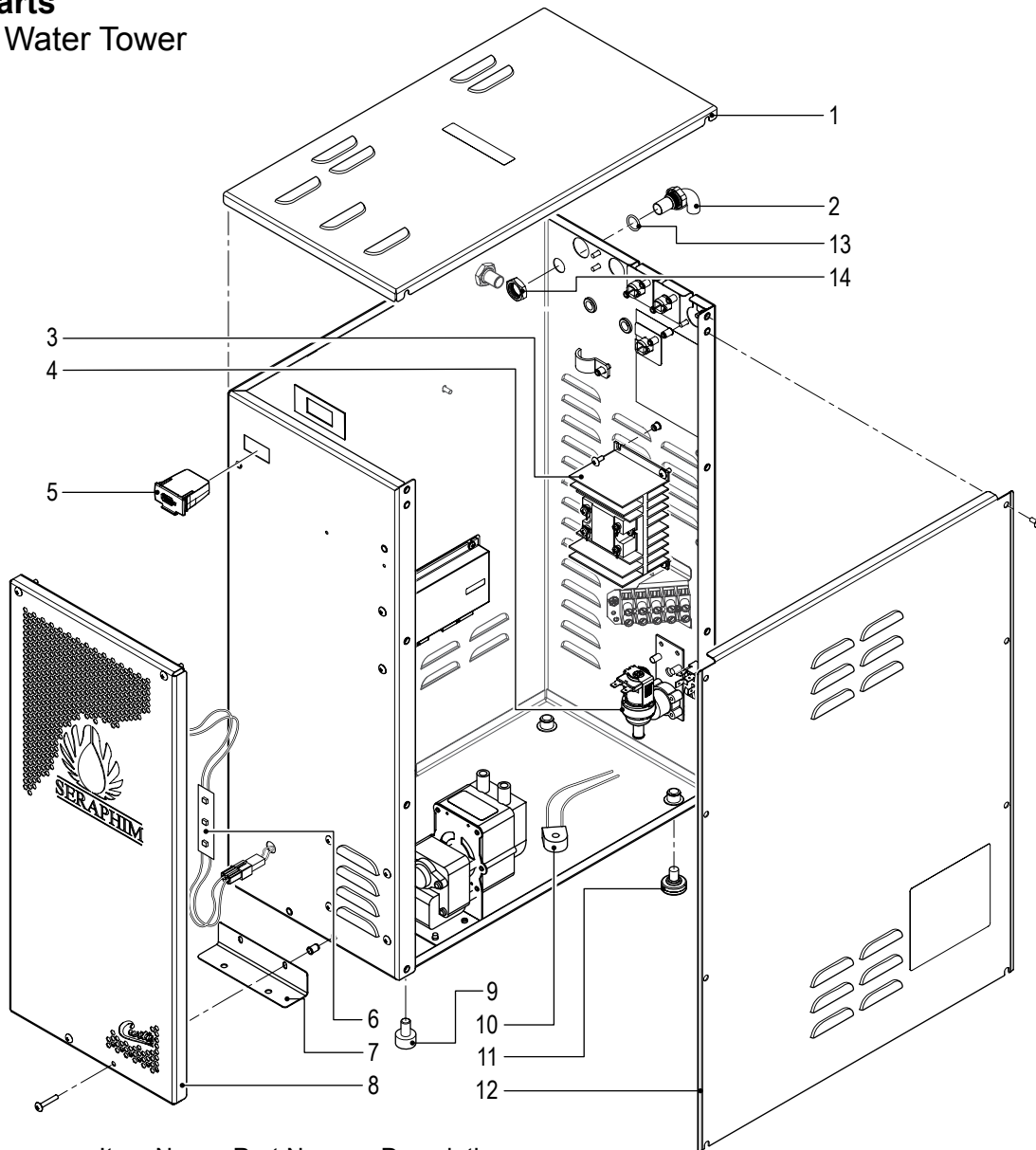

Item No	Part No	Description
1	WC-61643	COVER, TOP SERA
2	WC-2948	FITTING, TANK OVERFLOW 304SST
3	WC-8559*	RELAY, SOLID STATE 230V MAX W/INTEGRATED HEAT SINK
4	WC-847*	VALVE, INLET 2GPM 120V (SERA2)
4A	WC-883*	VALVE, INLET 2 GPM 240V 10W (SERA33)
5	WC-10008	UNIVERSAL HOST ADAPTER (USB-G4)
6	WC-1065	LED STRIP ASSY, 12Vdc x 1.2W 15 LEDs w/CONNECTORS
7	WC-61536	BRACKET SIDE
8	WC-73133	PLATE, FRONT FACE SERAPHIM LOGO
8A	WC-73133K	FRONT FACE W/LED
9	WC-3503*	LEG, 3/8"-16 STUD SCREW BUMPER
10	WC-14045-101*	CURRENT SENSOR ASSEMBLY G4
11	WC-3518*	LEG, GLIDE 3/8"-16 STUD SCREW
12	WC-61521	COVER, SIDE ACCESS
13	WC-4320*	O-RING, 1/2" I.D.
14	WC-4212	NUT, 5/8-18 JAM UNF NICKEL PLATED

* Recommended Parts to Stock

Illustrated Parts

Back View of Water Tower

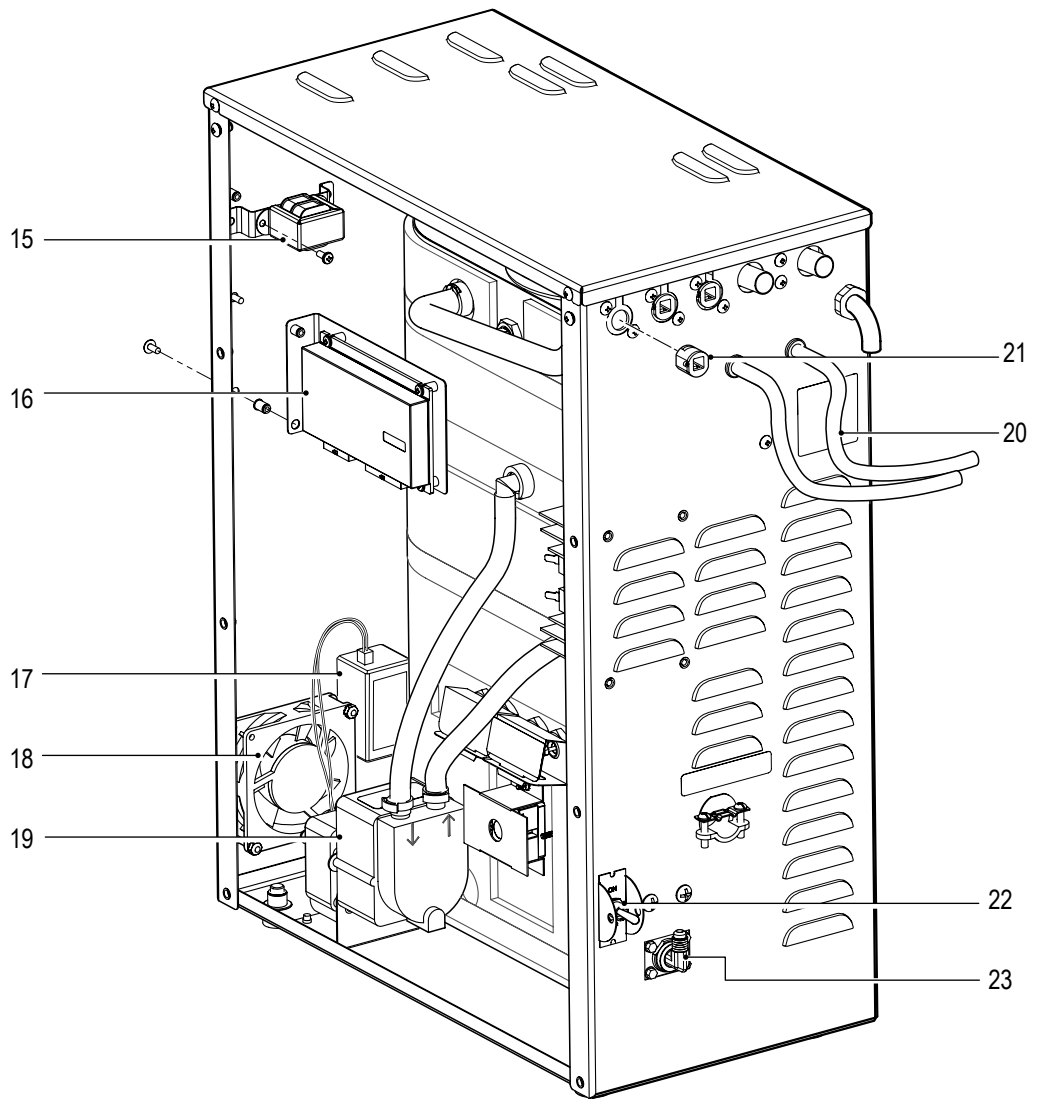

Item No	Part No	Description
15	WC-589-101*	TRANSFORMER, 120VAC-24V 4.8A W/TERMINALS (SERA2)
15A	WC-589-102	TRANSFORMER,240VAC- 24V 4.8VA (SERA33)
16	WC-10001*	CONTROL MODULE, UPM 120/220V G4
17	WC-1064*	POWER SUPPLY,100-240Vac X12Vdc W/CONNECTORS
18	WC-1066*	FAN, CHASSIS W/CONNECTORS SERAPHIM
19	WC-1040*	PUMP, WATER CENTRIFUGAL 120V 60Hz
20	WC-5307*	TUBE, 3/16 ID x 3/32W SILICONE (SOLD BY THE FOOT)
21	WC-14054	BUSHING, LOCKIT STRAIN RELIEF .220-.290 OD CABLE
22	WC-103*	SWITCH, TOGGLE DPST 25A 125/250VAC RESISTIVE
23	WC-2401	ELBOW, 3/8 NPT x 1/4 FLARE PLATED

* Recommended Parts to Stock

Illustrated Parts Brew Heads

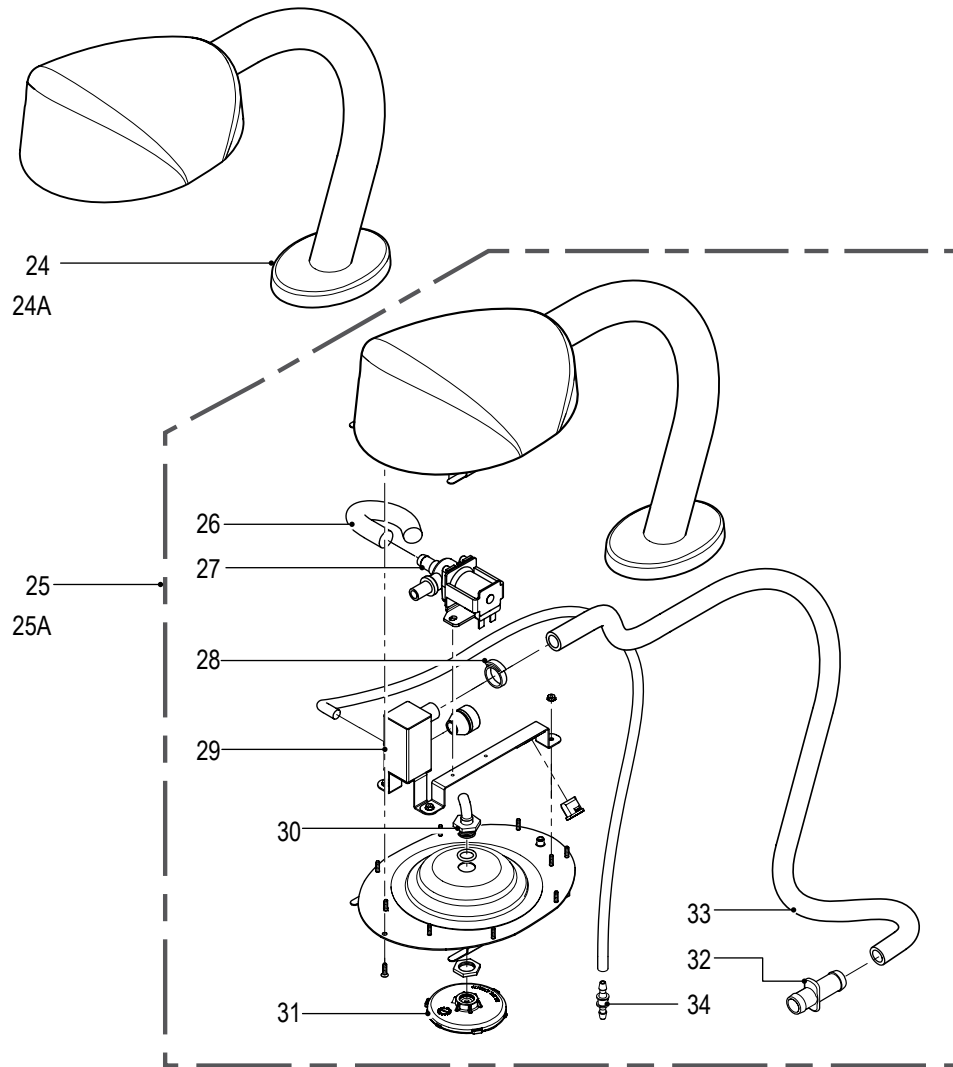

Item No	Part No	Description
24	WC-66099-BLK	HEAD, BREW ASSY SERAPHIM BLACK
24A	WC-66099-WHT	HEAD, BREW ASSY SERAPHIM WHITE
25	SERA-BH-BLK120	BREW HEAD ASSY, BLACK 120V COMPLETE (SERA2B)
25A	SERA-BH-WHT120	BREW HEAD ASSY, WHITE 120V COMPLETE (SERA2W)
25B	SERA-BH-BLK200	BREW HEAD ASSY, BLACK 200V (SERA33B)
25C	SERA-BH-WHT200	BREW HEAD ASSY, WHITE 200V (SERA33W)
26	WC-5310*	TUBE, 5/16 ID x 1/8W SILICONE
27	WC-889-103*	VALVE, DUMP LEFT 120V (SERA2)
27A	WC-12007-103*	VALVE, DUMP 200V 12W (SERA33)
28	WC-43813	CLAMP, HOSE SNAP-GRIP NYLON .750/.875
29	WC-66092K*	KIT, WEIR BOX & BUSHING
30	WC-37379*	KIT, SPRAYHEAD FITTING TLP
31	WC-29025	SPRAYHEAD, PURPLE ADVANCE FLOW
31A	WC-29065	SPRAYHEAD, GRAY ADVANCED FLOW
32	WC-2959-101	FITTING, STRAIGHT PLASTIC 12MM
33	WC-5350*	TUBE, 1/2 ID x 1/8W SILICONE (SOLD BY THE FOOT)
34	WC- 29105	COUPLER, 3/16" BARBED STRAIGHT

* Recommended Parts to Stock

Illustrated Parts

Heating Tank

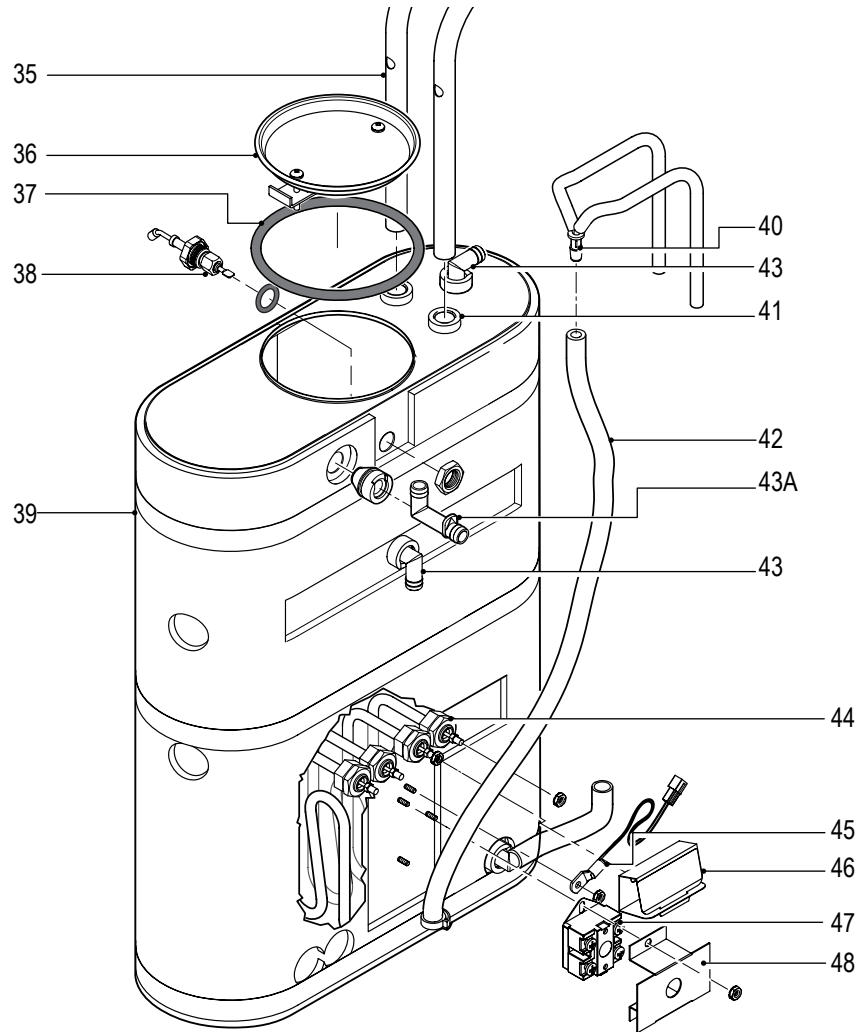

Item No	Part No	Description
35	WC-53162	TUBE, RETURN ASSEMBLY SERA
36	WC-37008	KIT, TANK LID ROUND
37	WC-43067*	O-RING, 4-1/2 I.D. x Ø.285 C.S. SILICONE
38	WC-5527K*	KIT, PROBE WATER LEVEL O-RING & NUT
39	WC-62107	TANK COMPLETE, (SERA2)
39A	WC-62107-33	TANK COMPLETE, (SERA33)
40	WC-2221	REDUCER, 3/16" TO 5/16" BARBED Y-CONNECTOR
41	WC-2628*	BUSHING, CONICAL .469 ID x .945 OD x .986 LG
42	WC-5310*	TUBE, 5/16 ID x 1/8 W SILICONE
43	WC-37365*	KIT, FITTING TANK INLET
43A	WC-37266*	KIT, FITTING TANK OVERFLOW
44	WC-934-04*	KIT, ELEMENT HEATING 2.5KW 220V, NUTS, WSHRS
44A	WC-906-04	KIT, HEATING ELEMENT 2.0KW 220V SERA33
45	WC-1438-101*	SENSOR, TEMPERATURE TANK
46	WC-4394	GUARD, SHOCK HEATING ELEMENT
47	WC-522*	THERMOSTAT, HI-LIMIT HEATER DPST 277V-40A
48	WC-43055	GUARD, SHOCK RESET THERMOSTAT

* Recommended Parts to Stock

Illustrated Parts

Touch Screen & Drip Tray

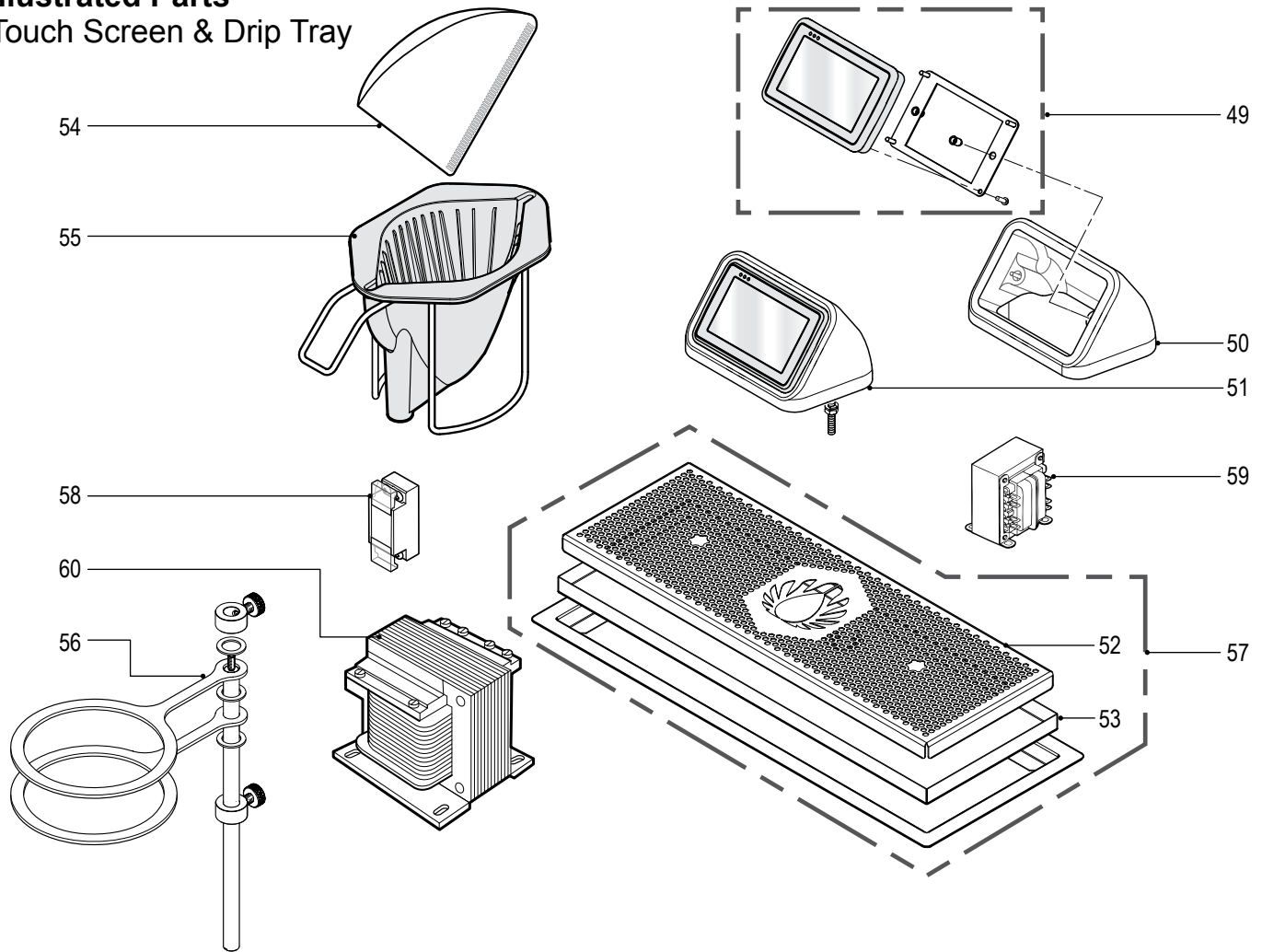

Item No	Part No	Description
49	WC-37580*	KIT, UCM & BACK PLATE
50	WC-66095-BLK	HOLDER, UCM SERAPHIM BLACK
50A	WC-66095-WHT	HOLDER, UCM SERAPHIM WHITE
51	SERA-UH-BLK	UCM HOLDER ASSY, BLACK COMPLETE
51A	SERA-UH-WHT	UCM HOLDER ASSY, WHITE COMPLETE
52	WC-65034	SCREEN, DRIP TRAY SERAPHIM
53	WC-65035	PAN, DRIP TRAY WITH DRAIN SERAPHIM
54	CGC4FILTER*	FILTER, PAPER COFFEE #4 40/PKG
55	WC-3411	BREW BASKET ASSEMBLY, OPEN BREW
56	WC-73141K	KIT, HOLDER BREW BASKET SERA
57	WC-65041	DRIP TRAY ASSY, COMPLETE
58	WC-596K	KIT, NOISE FILTER 250V/30A SERA30/33
59	WC-592	TRANSFORMER, 230-115V 130VA SERA30
60	WC-598	TRANSFORMER, 208-120V 100VA SERA33
61	WC-1512	BREAKER, CIRCUIT 2-POLE 5A/250V SERA33 (NOT SHOWN)

* Recommended Parts to Stock

Electrical Schematic SERA2

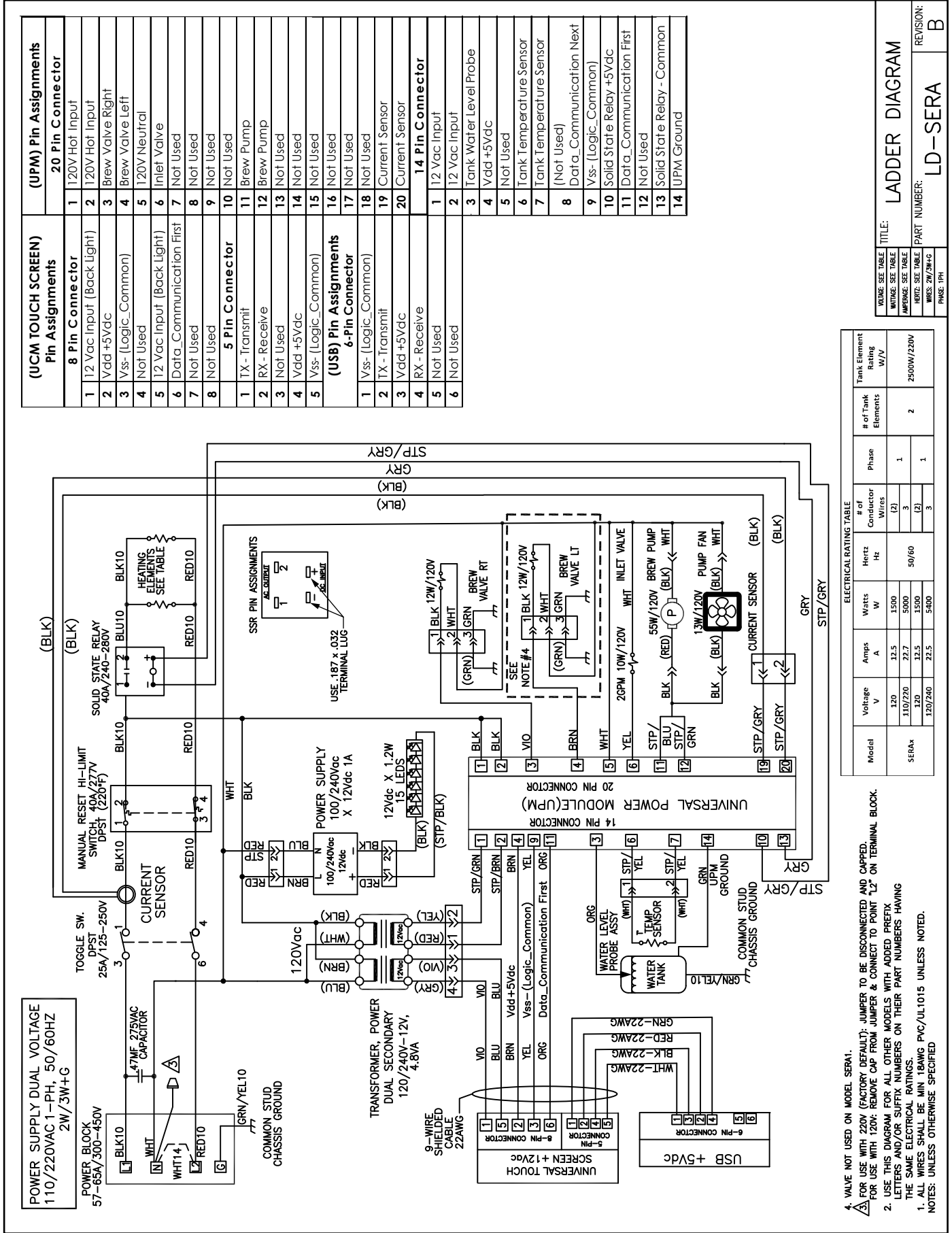

POWER SUPPLY DUAL VOLTAGE
110/220VAC 1-PH, 50/60HZ
57-65A/300-450V

POWER BLOCK
2W/3W+G

TOGGLE SW.
DPST
25A/125-250V

MANUAL RESET HI-LIMIT SWITCH
40A/277V
DPST (220F)

SOLID STATE RELAY
40A/240-280V

CURRENT SENSOR

HEATING ELEMENTS
SEE TABLE

POWER SUPPLY
100/240VAC
12Vdc 1A

TRANSFORMER, POWER
DUAL SECONDARY
120/240V-12V,
4.8VA

12Vdc X 1.2W
15 LEDs

SSR PIN ASSIGNMENTS

USE .187 x .032 TERMINAL LUG

14 PIN CONNECTOR

20 PIN CONNECTOR

UNIVERSAL TOUCH SCREEN + 12Vdc

6-PIN CONNECTOR

USB + 5Vdc

COMMON STUD CHASSIS GROUND

WATER TANK

WATER LEVEL PROBE ASSY

TEMP SENSOR

UPM GROUND

COMMON STUD CHASSIS GROUND

26GPM 10W/120V

55W/120V BREW PUMP

13W/120V PUMP FAN

CURRENT SENSOR

INLET VALVE

BREW VALVE RT

BREW VALVE LT

WHT 12W/120V

GRN BREW VALVE RT

BLK 12W/120V

SEE NOTE #4

WHT 12W/120V

(UCM TOUCH SCREEN) Pin Assignments

8 Pin Connector

1 12V Vac Input (Back Light)

2 Vdd +5Vdc

3 Vss- (Logic-Common)

4 Not Used

5 12V Vac Input (Back Light)

6 Data-Communication First

7 Not Used

8 Not Used

9 Not Used

10 Not Used

11 Brew Pump

12 Brew Pump

13 Not Used

14 Not Used

15 Not Used

16 Not Used

17 Not Used

18 Not Used

19 Current Sensor

20 Current Sensor

(USB) Pin Assignments

6-Pin Connector

1 Vss- (Logic-Common)

2 TX-Transmit

3 Vdd +5Vdc

4 RX-Receive

5 Not Used

6 Not Used

1 TX-Transmit

2 RX-Receive

3 Not Used

4 Vdd +5Vdc

5 Vss- (Logic-Common)

16 Not Used

(UPM) Pin Assignments

20 Pin Connector

1 120V Hot Input

2 120V Hot Input

3 Brew Valve Right

4 Brew Valve Left

5 120V Neutral

6 Inlet Valve

7 Not Used

8 Not Used

9 Not Used

10 Not Used

11 Brew Pump

12 Brew Pump

13 Not Used

14 Not Used

15 Not Used

16 Not Used

17 Not Used

18 Not Used

19 Current Sensor

20 Current Sensor

14 Pin Connector

1 12 Vac Input

2 12 Vac Input

3 Tank Water Level Probe

4 Vdd +5Vdc

5 Not Used

6 Tank Temperature Sensor

7 Tank Temperature Sensor

8 (Not Used)

9 Data-Communication Next

10 Vss- (Logic-Common)

11 Solid State Relay +5Vdc

12 Data-Communication First

13 Not Used

WIRE: SEE TABLE

WIRE: SEE TABLE

WIRE: SEE TABLE

WIRE: SEE TABLE

WIRE: SEE TABLE

WIRE: SEE TABLE

WIRE: SEE TABLE

WIRE: SEE TABLE

WIRE: SEE TABLE

WIRE: SEE TABLE

WIRE: SEE TABLE

WIRE: SEE TABLE

WIRE: SEE TABLE

WIRE: SEE TABLE

WIRE: SEE TABLE

WIRE: SEE TABLE

WIRE: SEE TABLE

WIRE: SEE TABLE

WIRE: SEE TABLE

WIRE: SEE TABLE

WIRE: SEE TABLE

WIRE: SEE TABLE

WIRE: SEE TABLE

WIRE: SEE TABLE

WIRE: SEE TABLE

WIRE: SEE TABLE

WIRE: SEE TABLE

WIRE: SEE TABLE

WIRE: SEE TABLE

WIRE: SEE TABLE

WIRE: SEE TABLE

WIRE: SEE TABLE

WIRE: SEE TABLE

WIRE: SEE TABLE

WIRE: SEE TABLE

WIRE: SEE TABLE

Model	Voltage V	Amps A	Watts W	Hz	# of Conductor Wires	Phase	# of Tank Elements	Tank Element Rating W/V
SERA2	120	12.5	1500	50/60	3	1	2	2500W/220V
	110/220	32.7	5000		3			
	120/240	32.5	1500		3			
	120/240	22.5	5000		3	1		

- VALVE NOT USED ON MODEL SERA1.
- FOR USE WITH 220V (FACTORY DEFAULT): JUMPER TO BE DISCONNECTED AND CAPPED. FOR USE WITH 120V: REMOVE CAP FROM JUMPER & CONNECT TO POINT "L2" ON TERMINAL BLOCK.
- USE THIS DIAGRAM FOR ALL OTHER MODELS WITH ADDED PREFIX LETTERS AND/OR SUFFIX NUMBERS ON THEIR PART NUMBERS HAVING THE SAME ELECTRICAL RATINGS.
- ALL WIRES SHALL BE MIN 18AWG PVC/UL1015 UNLESS NOTED. NOTES: UNLESS OTHERWISE SPECIFIED

TITLE: **LADDER DIAGRAM**
PART NUMBER: **LD-SERA**
REVISION: **B**

Cleaning the Coffee Brewer

Regular cleaning and preventive maintenance is essential in keeping your coffee brewer looking and working like new.



CAUTION – Do not use cleaning liquids, compounds or powders containing chlorine (bleach) or corrosives. These products promote corrosion and will pit the stainless steel parts. USE OF THESE PRODUCTS WILL VOID THE WARRANTY.

DAILY CLEANING

1. Mix dishwashing liquid in warm water to make a mild cleaning solution.
2. Drain the drip tray. Wash the tray and screen. Dry these parts.
3. Wipe exterior surfaces with a cloth moistened with the cleaning solution. Clean off dried coffee, spills and debris.
4. Wipe exterior surfaces with a cloth soaked in clean water to remove all traces of the cleaning solution.
5. Slide the brew baskets out and clean them with the detergent solution and a soft brush.
6. Rinse and dry the brew baskets. Return them onto the brew rails.
7. Dry exterior surfaces with a clean soft cloth.

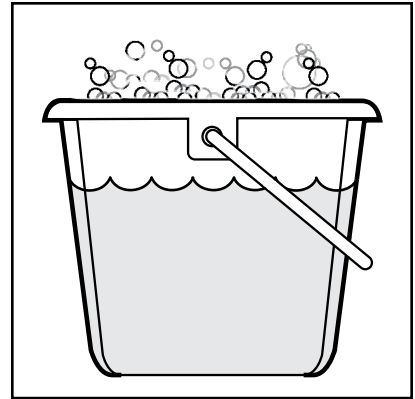

WEEKLY CLEANING

1. Turn off the brewer at the power switch, on the right side behind the water tower.
2. Remove the spray head, unscrewing counterclockwise from the dome plate. Rinse the spray head.
3. With a cloth soaked with a mild detergent solution, thoroughly clean dome plate area.
4. Clean the brew basket rails with a brush. Rinse with a water soaked cloth. Dry the area with a clean cloth.
5. Attach the spray head and insert the brew basket into the brew rails.
6. Restore the electrical power to the brewer.

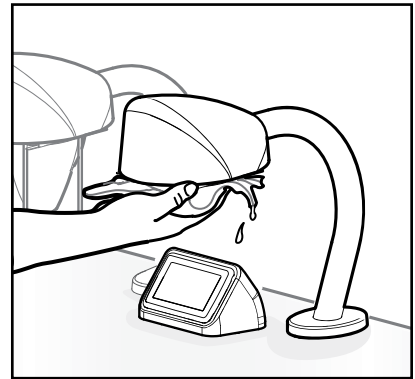

Liquid Level Probe

Cleaning intervals for the probe are to be determined by the user or the service tech, based on water conditions. The use of water filters, or the type of water filter that is being used can impact the service interval. Intervals can be from one month to several years, however, replacing rather than cleaning the probe is preferable.



WARNING: This procedure is to be performed only by qualified service personnel. Disconnect electrical power before removing the access panels. This procedure involves working with hot water and hot surfaces.

1. Unplug the power cord and shut off the water supply.
2. Remove the top cover of the water tower. Locate the top of the water tank and remove the cover.
3. Drain the water tank to a level about 3" below the tip of the probe.
4. Allow some time for the probe to cool before working on the brewer.
5. Clean the tip of the probe using a Scotch-Brite™ scuff pad.
6. If a residual white layer is still visible on the probe, remove the probe and soak it in vinegar or a scale removing chemical. Repeat this step until the white layer is removed.
7. When assembling the probe back onto the tank, make sure the tip of the probe is pointing downward as illustrated.

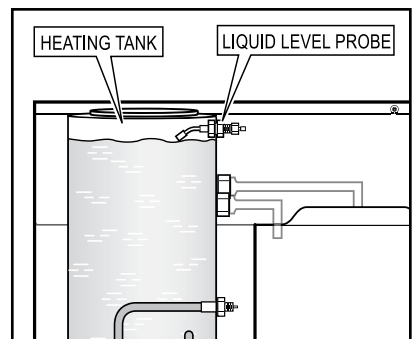
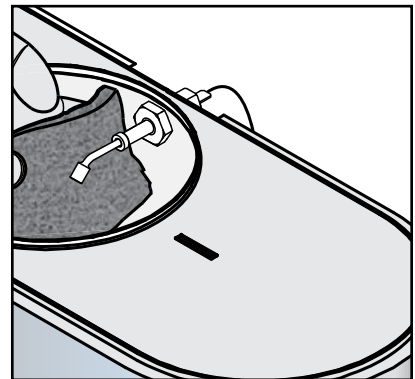

Caring for the LCD Display

To remove light smears or grime, wipe the surface with a dry, clean, soft cloth. To remove severe grime, wipe the surface with a soft cloth dampened in clean water or diluted mild detergent. Then wipe immediately with a dry cloth.



CAUTION: Do not push, rub or hit the surface with your fingernail or a sharp object. Doing so may result in scratches on the screen and image distortions.

Do not use any chemicals, such as waxes, benzene, alcohol, thinners, insecticides, air fresheners or lubricants. They may damage the screen's finish and cause discoloration.

Cleaning the Brew Baskets

Clean the dispensing spout of the brew basket once a month or more often in locations where the brewer gets heavy use.

1. Look into the brew basket to locate the cap covering the spout tube. Remove this cap by grasping the top portion and pulling it straight up.

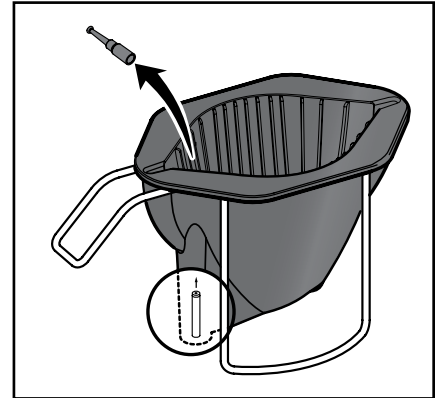

2. Clean the inside orifice of the spout tube. For better cleaning, you can mix a mild dish washing solution to use while cleaning. Insert a small brush through the spout tube from the outside of the brew basket. Spin the brush a few times to remove any coffee residue. Look inside the brew basket and verify that the brush has gone completely through the spout.

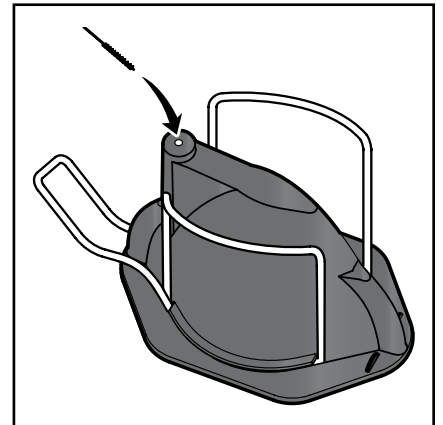

3. Clean the small opening on the side of the spout tube. Insert the brush into the side opening and spin it a few times. Run the brush completely through the side opening.
4. Rinse the brew basket with clear water. Observe the flow of water from the dispensing spout to make sure you have a good flow. Replace the cap on top of the spout tube. Push down on the cap until it snaps into place.

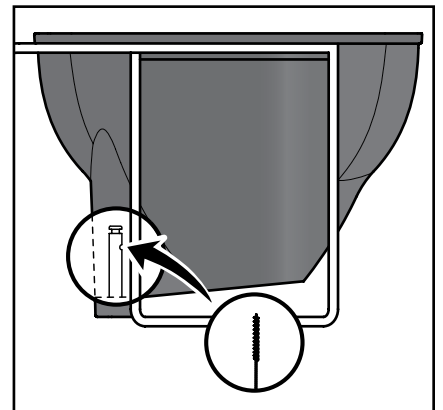

Rough-In Drawing

SERA2

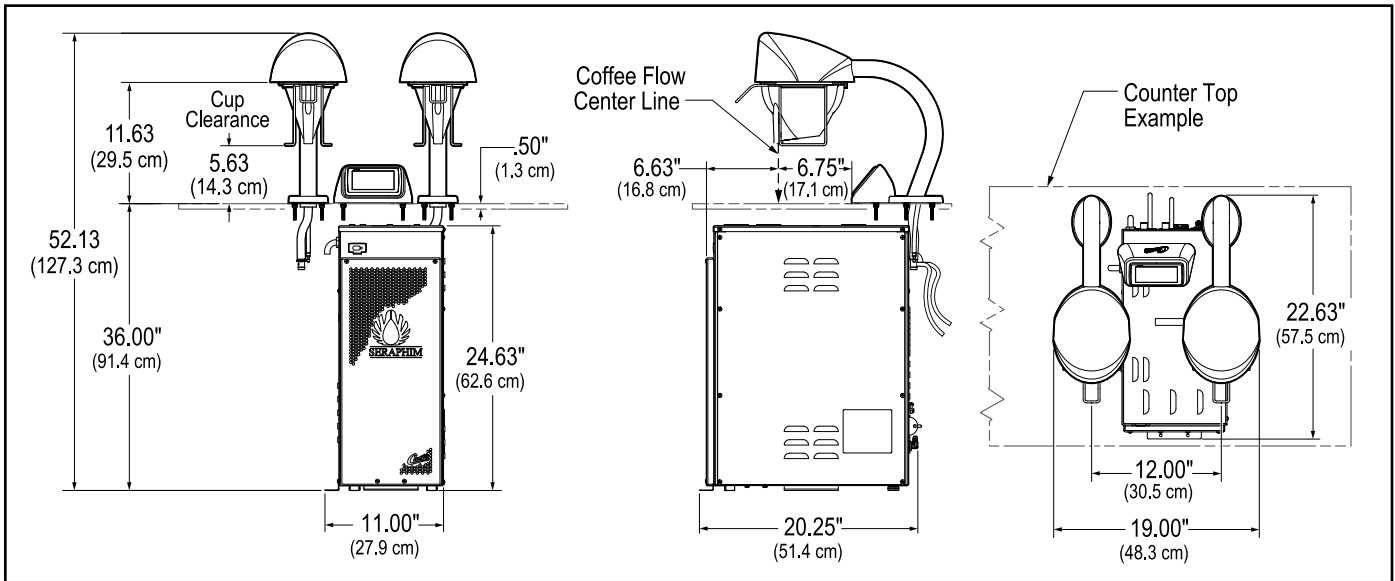

Product Warranty (3-2-1)

Wilbur Curtis Co., Inc. certifies that its products are free from defects in material and workmanship under normal use. The following limited warranties and conditions apply:

- 3 years, parts and labor, from original date of purchase on digital control boards
- 2 years, parts, from original date of purchase on all other electrical components, fittings and tubing
- 1 year, labor, from original date of purchase on all other electrical components, fittings and tubing

Additionally, Wilbur Curtis Co., Inc. warrants its grinding burrs for forty (40) months from the date of purchase or 40,000 pounds of coffee, whichever comes first. Stainless steel components are warranted for two (2) years from the date of purchase against leaking or pitting. Replacement parts are warranted for ninety (90) days from the date of purchase or for the remainder of the limited warranty period of the equipment in which the component is installed.

All in-warranty service calls must have prior authorization. For authorization, call the Technical Support Department at 800-995-0417. Additional conditions may apply. Go to www.wilburcurtis.com to view the full product warranty information.

CONDITIONS & EXCEPTIONS

The warranty covers original equipment at time of purchase only. Wilbur Curtis Co., Inc., assumes no responsibility for substitute replacement parts installed on Curtis equipment that have not been purchased from Wilbur Curtis Co., Inc. Wilbur Curtis Co., Inc. will not accept any responsibility if the following conditions are not met. The warranty does not cover:

- **Adjustments and cleaning:** *The resetting of safety thermostats and circuit breakers, programming and temperature adjustments are the responsibility of the equipment owner. The owner is responsible for proper cleaning and regular maintenance of this equipment.*
- **Replacement of items subject to normal use and wear:** *This shall include, but is not limited to, spray heads, light bulbs, shear disks, "O" rings, gaskets, silicone tubing, canister assemblies, whipper chambers and plates, mixing bowls, agitation assemblies and whipper propellers.*

The warranty is void under the following circumstances:

- **Improper operation of equipment:** *The equipment must be used for its designed and intended purpose and function.*
- **Improper installation of equipment:** *This equipment must be installed by a professional technician and must comply with all local electrical, mechanical and plumbing codes.*
- **Improper voltage:** *Equipment must be installed at the voltage stated on the serial plate supplied with this equipment.*
- **Improper water supply:** *This includes, but is not limited to, excessive or low water pressure and inadequate or fluctuating water flow rate.*
- **Damaged in transit:** *Equipment damaged in transit is the responsibility of the freight company and a claim should be made with the carrier.*
- **Abuse or neglect (including failure to periodically clean or remove lime accumulations):** *The manufacturer is not responsible for variation in equipment operation due to excessive lime or local water conditions. The equipment must be maintained according to the manufacturer's recommendations.*

Repairs and/or Replacements are subject to Curtis' decision that the workmanship or parts were faulty and the defects showed up under normal use. All labor shall be performed during regular working hours. Overtime charges are the responsibility of the owner. Charges incurred by delays, waiting time, or operating restrictions that hinder the service technician's ability to perform service is the responsibility of the owner of the equipment. This includes institutional and correctional facilities. Wilbur Curtis Co., Inc. will allow up to 100 miles, round trip, per in-warranty service call.

Return Merchandise Authorization (RMA): All claims under this warranty must be submitted to the Wilbur Curtis Technical Support Department prior to performing any repair work or return of this equipment to the factory. **All returned equipment must be properly re-packaged in the original carton and received by Curtis within 45 days following the issuance of a RMA.** No units will be accepted if they are damaged in transit due to improper packaging. **NO UNITS OR PARTS WILL BE ACCEPTED WITHOUT A RETURN MERCHANDISE AUTHORIZATION (RMA). THE RMA NUMBER MUST BE MARKED ON THE CARTON OR SHIPPING LABEL.** All warranty claims must be submitted within **60 days of service.** Invoices will not be processed or accepted without a RMA number. Any defective parts must be returned in order for warranty invoices to be processed and approved. All in-warranty service calls must be performed by an authorized service agent. Call the Wilbur Curtis Technical Support Department to find an agent near you.

ECN17296 05/12/16 @ 8.8 rev E



WILBUR CURTIS CO., INC.

6913 Acco St., Montebello, CA 90640-5403 USA | Phone: 800-421-6150 | Fax: 323-837-2410
Technical Support Phone: 800-995-0417 (M-F 5:30 A.M. - 4:00 P.M. PST)
Email: techsupport@wilburcurtis.com | Web: www.wilburcurtis.com

05/2016 F-4009 rev E