

ELECTRICAL

MODEL	VOLTS	WATTS	AMPS	PHASE	FIELD WIRING GAUGE	TEMP. RATING
SS-10	120	450	3.8	SINGLE	14 AWB Cu	75°C
SS-10	208	338	1.6	SINGLE	14 AWB Cu	75°C
SS-10	240	450	1.9	SINGLE	14 AWB Cu	75°C
SS-10D	120	450	3.8	SINGLE	14 AWB Cu	75°C
SS-10D	208	338	1.6	SINGLE	14 AWB Cu	75°C
SS-10D	240	450	1.9	SINGLE	14 AWB Cu	75°C

INSTALLATION INSTRUCTIONS BUILT-IN ROUND FOOD WARMERS MODELS SS-10 (D)

CLEARANCES

SUGGESTED CLEARANCES UNIT TO THE NEAREST SURFACE

BACK	SIDE	BOTTOM	FRONT
$\frac{1}{(25)}$	$\frac{1}{(25)}$	$\frac{8\ 1/2}{(216)}$	$\frac{4}{(102)}$

SEE CONDITIONS OF ACCEPTABILITY BELOW

WHEN CONTROL BOX IS LOCATED BELOW THE UNIT, FRONT CLEARANCE CAN BE 2 INCHES.

NOTE: DEPENDING ON THE INSTALLATION, CLEARANCES CAN BE CHANGED UPON EVALUATIONS TO UL STANDARDS.

CUTOUT DETAILS

INCHES
(MM)

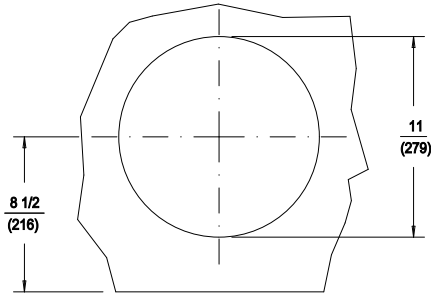

TOP CUTOUT

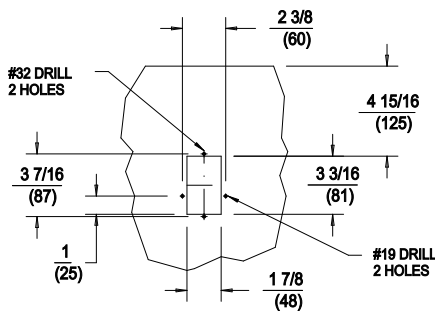

FRONT PANEL CUTOUT

PRODUCT DIMENSIONS

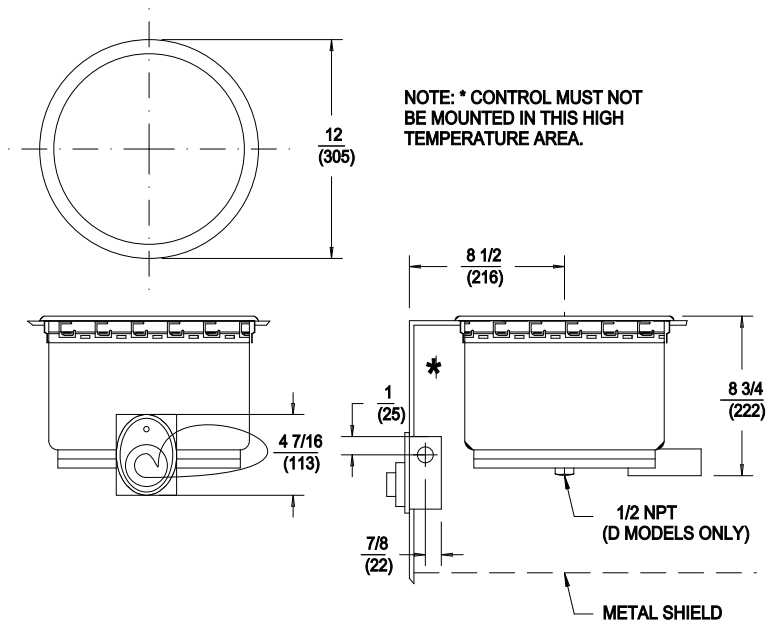

NOTE: * CONTROL MUST NOT BE MOUNTED IN THIS HIGH TEMPERATURE AREA.

INSTALLATION INSTRUCTIONS

UNIT MUST BE INSTALLED IN AN ALL METAL COUNTER. THE INSTALLATION OF RECOGNIZED COMPONENT UNITS REQUIRES ADDITIONAL EVALUATIONS TO UNDERWRITERS LABORATORIES INC. STANDARDS.

INSTALLER MUST MEET CONDITIONS OF ACCEPTABILITY OUTLINED BELOW UPON INSTALLATION:

1. This appliance shall be installed in an all metal counter with suitable wiring and control enclosures conforming to national and local electrical codes.
2. Electrical component temperatures, including wiring, within and surrounding the appliance must be monitored in the end use installation for suitability.
3. Electrical grounding of all dead metal parts must be reliably connected to the grounding means of the appliance and must comply with the requirements outlined in appropriate Underwriters Laboratories Inc. classification, national and local electrical codes.
4. Increased clearances are required if storage of combustible materials is in close proximity to this appliance.
5. Unit shall be accessible for servicing from the bottom.
6. The name/rating plate information shall be accessible.
7. For water and waste connections: This appliance is to be installed to comply with the applicable federal, state or local plumbing codes.

TO FABRICATE:

1. Lay out "cutout" dimensions on countertop and front apron.
2. Lay out and fabricate control panel holes in counter apron using the control box as a template.
3. Cut out and/or drill holes as required in countertop and apron.
4. Unit must be accessible for servicing from the bottom.

TO INSTALL:

1. Locate warmer and control box over countertop cutout. Pass control through opening, then mount control electrical box to the rear of the apron.
 2. Apply a bead of silicone adhesive/sealant to the gasket supplied on the underside of the warmer flange then seat the warmer onto the countertop. Properly position.
 3. From underneath, insert a screwdriver into "slots" on the wellslok frame and twist the "ears" outward to secure the flange tightly to the countertop (see detail above).
 4. Mount the control panel to the front of the counter apron using the screws supplied.
- RECOMMENDATION: Units with drains should be installed with a union for ease of service.

