



Outperform every day.™

# Operator's Manual

## Vertical Contact Toaster

Model CBT15

Thank you for purchasing this Vollrath equipment. Before operating the equipment, read and familiarize yourself with the following operating and safety instructions. **SAVE THESE INSTRUCTIONS FOR FUTURE REFERENCE.** Save the original box and packaging. Use this packaging to ship the equipment if repairs are needed.

### SAFETY PRECAUTIONS

To ensure safe operation, read the following statements and understand their meaning. This manual contains safety precautions which are explained below. Please read carefully.

#### **WARNING**

Warning is used to indicate the presence of a hazard that will or can cause severe personal injury or death.

#### **CAUTION**

Caution is used to indicate the presence of a hazard that will or can cause minor or major personal injury if the caution is ignored.

**NOTICE:** Notice is used to note information that is important but not hazard-related.

#### **To reduce risk of injury or damage to the equipment**

- Plug only into grounded electrical outlets matching the voltage on the rating plate.
- Use this equipment in a flat, level position.
- Unplug equipment and let it cool before cleaning or moving. Equipment remains hot after it is turned off.
- Unplug when not in use.
- Keep equipment and power cord away from open flames, electric burners or excessive heat.
- Do not operate unattended.
- Closely supervise equipment operating in public areas and/or around children.
- Do not operate if equipment has been damaged or is malfunctioning.

### FUNCTION AND PURPOSE

This equipment is intended to toast bread products. It is intended for use in mid-size commercial kitchens that need to toast different bread products at the same time. Not intended for high-volume toasting operations or household, industrial or laboratory use.

### CLEARANCE AND ENVIRONMENT REQUIREMENTS

Do not place toaster on surfaces or near walls, partitions or kitchen furniture unless they are made of non-combustible material or clad with non-combustible heat-insulating material. Toasters must not be used near or below curtains and other combustible materials. Do not place the toaster adjacent to a heat producing appliance.



Item No.	Model	Description
VCT4-208	CBT15	Vertical Contact Toaster, 208V
VCT4-240		Vertical Contact Toaster, 240V

### SET UP

1. Place the toaster on a hard, flat, stable surface.
2. Install the collection pan by placing the back edge of the pan on the lip at the back of the toaster. Line up the hole in the pan with the screw at the back of the toaster. Tighten the screw to secure the collection pan.

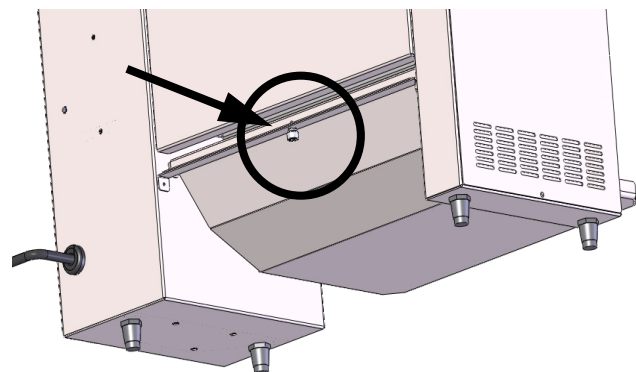

### BEFORE FIRST USE

1. Clean the toaster. See "Daily Cleaning" on page 3.

Register your product at [Vollrath.com/registration](http://Vollrath.com/registration) and become eligible to win a free 10" Vollrath Tribute® fry pan.

## FEATURES

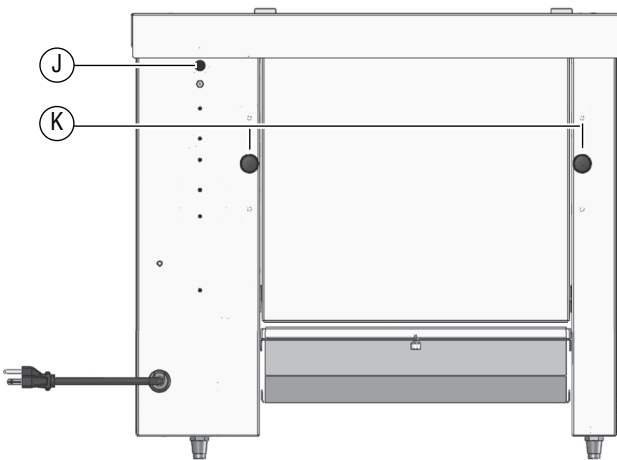

- A Platen** (Under the release sheet). Toasts the cut side of the bun
- B Release Sheet**. Prevents buns from sticking to platen.
- C Platen Adjustment**. Adjusts the compression on the front slot.
- D Heat Control Knob**
- E Front Slot Speed Control**
- F Rear Slot Speed Control**
- G Power LED**. Illuminates when power to the toaster is ON.
- H On/OFF1 Switch**
- I Collection Pan**
- J Reset Button**
- K Platen Adjustment**. Adjusts the compression on the rear slot.

## OPERATION

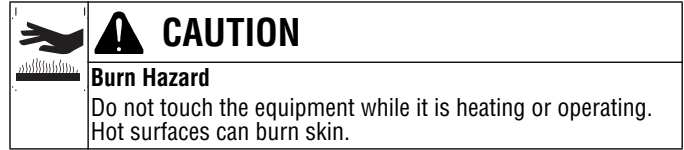

**NOTICE:** The release sheet must be installed over the platen during operation. Failure to install the release sheet may damage the toaster and void the warranty.

### Preheat

1. Plug the toaster into a grounded electrical outlet that matches the rating on the name plate found on the side of the toaster.

**NOTICE:** Using a voltage other than the nameplate rated voltage will cause damage to the unit. Incorrect voltage, modification to the power cord or electrical components can damage unit and will void the warranty.

2. Rotate the platen adjustment knobs for each slot to accommodate the bun to be toasted.
3. Switch the power switch to the ON position.
4. Set the speed control knobs to 7.
5. Rotate the heat control knob to the highest setting.
6. Wait 30-45 minutes for the toaster to preheat.

### Test

1. Adjust the settings for the product to be toasted. Test the settings by placing a sample of the buns to be toasted onto the slots at the top of the toaster with the cut side facing the platen.
2. Evaluate the results.

### Toast Buns

1. Adjust the heat control and conveyor speed settings as needed. Allow time for the toaster to adjust to new heat settings.

### If a Bun Becomes Stuck

1. Switch the power switch to the OFF position.
2. Let the toaster cool completely.
3. Use tongs to remove the bread item.

## CLEANING

	<b>WARNING</b>
	<b>Electrical Shock Hazard</b>
	Do not spray water or cleaning products. Liquid could contact the electrical components and cause a short circuit or an electrical shock.

	<b>CAUTION</b>
	<b>Burn Hazard</b>
	Allow equipment to cool before moving or cleaning.

**NOTICE:** Do not use abrasive materials, scratching cleansers or scouring pads to clean the exterior of the equipment. These can damage the finish.

### Daily Cleaning

1. Switch the power switch to the OFF position and unplug the toaster.
2. Let the toaster cool completely.
3. Remove the top cover and clean it with a soft cloth dampened with warm water.
4. Use the dampened cloth to clean the exterior of the toaster and the air intake on the side of the toaster and the collection tray.

## PREVENTATIVE MAINTENANCE

Contact an authorized service agent for a professional cleaning of the components.

## TROUBLESHOOTING

Problem	Might be Caused By	Course of Action
Toaster does not heat and the conveyor does not move.	Toaster is not plugged in.	Plug in the toaster.
	The wall breaker may be tripped.	Reset the breaker.
	The reset may be tripped.	Look on the side of the toaster to see if an object is preventing the fan blades from turning. 1. Remove the object. 2. Press the reset button on the back of the toaster. See "Features" on page 2 for the location. 3. If the problem persists call Vollrath Technical Services.
		Inspect the fan blades to see if they are dirty. 1. Switch the power switch to the OFF position. 2. Unplug the toaster. 3. Wait 30 minutes for the toaster cool. 4. Clean the fan blades. 5. Plug in the toaster. 6. Switch the power switch to the ON position. 7. Press the reset button. 8. If the problem persists call Vollrath Technical Services.
	The top cover may not be installed or may be loose.	Inspect the cover to make sure it is properly installed. If the problem persists call Vollrath Technical Services.
Toaster heats but one or both conveyors do not work.	There may be a problem with the motor/speed control or drive chain.	Contact Vollrath Technical Services.
Toaster does not heat.	One or more heater elements may be burned out or there may be a problem with the heat control.	Contact Vollrath Technical Services.
Toaster heat does not adjust after changing the heat setting and toaster is burning the buns.	The heat relay may be defective.	
Toaster repeatedly overheats.	The fan may be dirty.	Verify the fan blades are clean.
	There may be a problem with the fan.	Run the toaster for 10 minutes. If the fan does not run, contact Vollrath Technical Services.
Fan is not running.	There may be a problem with the fan or fan switch.	Run the toaster for 10 minutes. If the fan does not run, contact Vollrath Technical Services.
Toaster is turned off and the fan is running.	Normal operation. The fan turns on as needed to cool the toaster.	–

---

## SERVICE AND REPAIR

---

When under warranty, repair is available for this product. To begin the process:

1. Contact Vollrath Technical Services at 1-800-309-2250. Please be ready with the item number, model number and serial number. You can find this information on the nameplate located on the side or back of the equipment. Also please provide a proof of purchase indicating the date the equipment was purchased.
2. A technical services representative will help you troubleshoot the problem over the phone.
3. If the representative determines the issue requires professional service, he or she will help you locate an authorized service center.
4. Contact the authorized service center to make arrangements for the repair. Vollrath will cover the cost to repair and/or replace defective parts within the equipment warranty period.

---

## WARRANTY STATEMENT FOR THE VOLLRATH CO. L.L.C.

---

The Vollrath Company LLC warrants the products it manufactures or distributes against defects in materials and workmanship as specifically described in our full warranty statement. In all cases, the warranty runs from the date of the end user's original purchase date found on the receipt. Any damages from improper use, abuse, modification or damage resulting from improper packaging during return shipment for warranty repair will not be covered under warranty.

The warranty does not apply to products purchased for personal, family or household use, and The Vollrath Company LLC does not offer a written warranty to purchasers for such uses.

Warranted Parts: The warranty period is 2 years parts, 1 year labor.

Heater Tubes: The warranty period is 1 year, including labor. Heater tube glass damage is not covered by this warranty.

For complete warranty information, product registration and new product announcements, visit [www.vollrath.com](http://www.vollrath.com).



Outperform every day.™

[www.vollrath.com](http://www.vollrath.com)

---

### The Vollrath Company, L.L.C.

1236 North 18th Street  
Sheboygan, WI 53081-3201 U.S.A.  
Main Tel: 800.624.2051 or 920.457.4851  
Main Fax: 800.752.5620 or 920.459.6573  
Customer Service: 800.628.0830  
Canada Customer Service: 800.695.8560

### Technical Services

[techservicereps@vollrathco.com](mailto:techservicereps@vollrathco.com)  
Toasters: 1-800-309-2250  
All Other Products: 800.628.0832