

BLODGETT® **BLODGETT**® **BLODGETT**® **BLODGETT**®

BLODGETT® **BLODGETT**® **BLODGETT**®

BLODGETT® **BLODGETT**® **BLODGETT**® **BLODGETT**®

BLODGETT®

SN-5G, SC-7G and SC-10G
GAS FIRED CONVECTION STEAMER
INSTALLATION – OPERATION – MAINTENANCE



BLODGETT OVEN COMPANY

www.blodgett.com

44 Lakeside Avenue, Burlington, Vermont 05401 USA Telephone: (802) 658-6600 Fax: (802) 864-0183

S00041 Rev C (10/11)

IMPORTANT NOTES FOR INSTALLATION AND OPERATION



This is the safety alert symbol. It is used to alert you to potential personal injury hazards. Obey all safety messages that follow this symbol to avoid possible injury or death.



WARNING: Improper installation, operation, adjustment, alteration, service or maintenance can cause property damage, injury or death. Read the installation, operating and maintenance instructions thoroughly before installing, operating or servicing this equipment.



FOR YOUR SAFETY: Do not store or use gasoline or other flammable vapours and liquids in the vicinity of this or any other appliance.



PURCHASER: Instructions to be followed in the event that the operator of this appliance smells gas must be posted in a prominent location. This information shall be obtained by consulting the local gas supplier.

Keep the appliance area free and clear from combustibles.

Do not obstruct the flow of combustion and ventilation air.

Adequate clearances must be maintained for servicing and proper operation.

Do not attempt to operate this unit in the event of a power failure.

This manual should be retained for future reference.

TABLE OF CONTENTS

DESCRIPTION	PAGE
1.0 Service Connections	4
2.0 Installation	6
3.0 Performance Check	11
4.0 Operation Instructions	12
5.0 Periodic Maintenance	15
6.0 Deliming Procedure	18
7.0 Troubleshooting.....	19

1.0 SERVICE CONNECTIONS – SN-5G

SERVICE CONNECTIONS

- ⚡ - Unless otherwise specified, Field Wire Electrical Connection to be 120 Volts, 60 Hertz single phase with grounding wire. Furnished with 6 foot cord with 3 prong plug. Maximum amps 2.0.
- Ⓛ - DRAIN: 1"IPS piped to open floor drain. No Solid Connection. Copper only. 24" maximum length before open air gap opening. (No bends or elbows)
- ⚡ - GAS CONNECTION: 3/4"IPS supply line required. A gas shut-off valve must be installed in supply piping convenient and adjacent to appliance.
- Ⓛ - GENERATOR WATER: 3/8" O.D. tubing at 25-50 PSI(170-345 kPa)
- Ⓛ - CONDENSING WATER: 3/8" O.D. tubing at 25-50 PSI(170-345 kPa)
- Ⓛ - DELIME PORT: 3/4"IPS

WATER QUALITY STATEMENT

Water quality is the major factor affecting the performance of your appliance. If you are unsure of water quality, consult a local water treatment specialist and have the water analyzed. Your water supply must be within these general guidelines:

Total dissolved solids	Less than 60 PPM
Total alkalinity	Less than 20 PPM
Silica	Less than 13 PPM
Chlorine	Less than 1.5 PPM
pH Factor	7.0-8.5

Water which fails to meet these standards should be treated by installation of water conditioner.

FAILURE OR MALFUNCTION OF THIS APPLIANCE DUE TO POOR WATER QUALITY IS NOT COVERED UNDER WARRANTY.

MODEL	GAS SUPPLY					MIN. CLEARANCE		
	SHIPPING WT.	BTU/HR.	kW/HR.	SUPPLY PIPE PRESSURE (W.C.)		LH	RH	BACK
SN-5G	250 lbs. [113 kg]	42,000	12.3	Natural 6"-14"(152-356mm)	Propane 11"-14"(279-356mm)	3 [76]	8 [203]	6 [152]

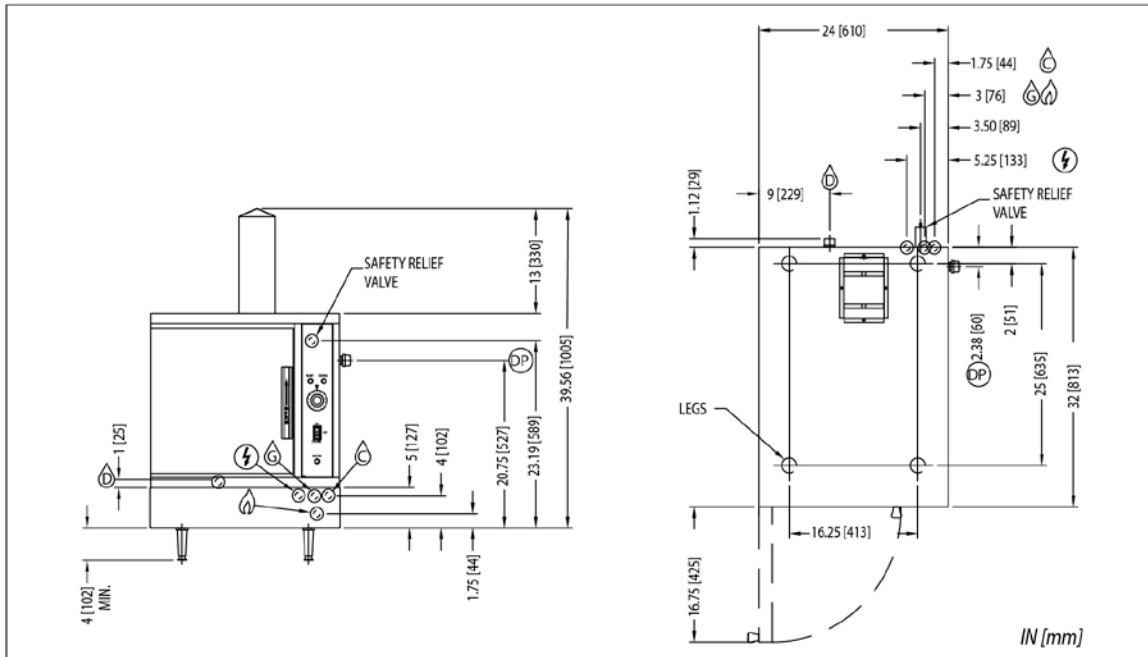

SERVICE CONNECTIONS – SC-7G and SC-10G

SERVICE CONNECTIONS

- ⚡ - Electrical Connection to be 120 Volts, 60 Hertz single phase with grounding wire. Furnished with 6 foot cord with 3 prong plug. Maximum amps 4.0.
- Ⓛ - DRAIN: 1"IPS piped to open floor drain. No Solid Connection. Use copper only. 24" length before open air gap opening. (No bends or elbows)
- Ⓜ - GAS CONNECTION: 3/4"IPS supply line required.
- Ⓜ - GENERATOR WATER: 3/8" O.D. tubing at 25-50 PSI(170-345 kPa)
- Ⓜ - CONDENSING WATER: 3/8" O.D. tubing at 25-50 PSI(170-345 kPa)
- Ⓛ - DELIME PORT: 3/4"IPS

WATER QUALITY STATEMENT

Water quality is the major factor affecting the performance of your appliance. If you are unsure of water quality, consult a local water treatment specialist and have the water analyzed. Your water supply must be within these general guidelines:

Total dissolved solids	Less than 60 PPM
Total alkalinity	Less than 20 PPM
Silica	Less than 13 PPM
Chlorine	Less than 1.5 PPM
pH Factor	7.0-8.5

Water which fails to meet these standards should be treated by installation of water conditioner.

FAILURE OR MALFUNCTION OF THIS APPLIANCE DUE TO POOR WATER QUALITY IS NOT COVERED UNDER WARRANTY.

MODEL	SHIPPING WT.	GAS SUPPLY		MIN. CLEARANCE				
		BTU/HR.	KW/HR.	SUPPLY PIPE PRESSURE (W.C.)		LH	RH	BACK
SC-7G	625 lbs. [285 kg]	84,000	24.6	Natural	Propane	3	8	6
SC-10G	675 lbs. [305 kg]			6"-14" [152-356mm]	11"-14" [279-356mm]	[76]	[203]	[152]

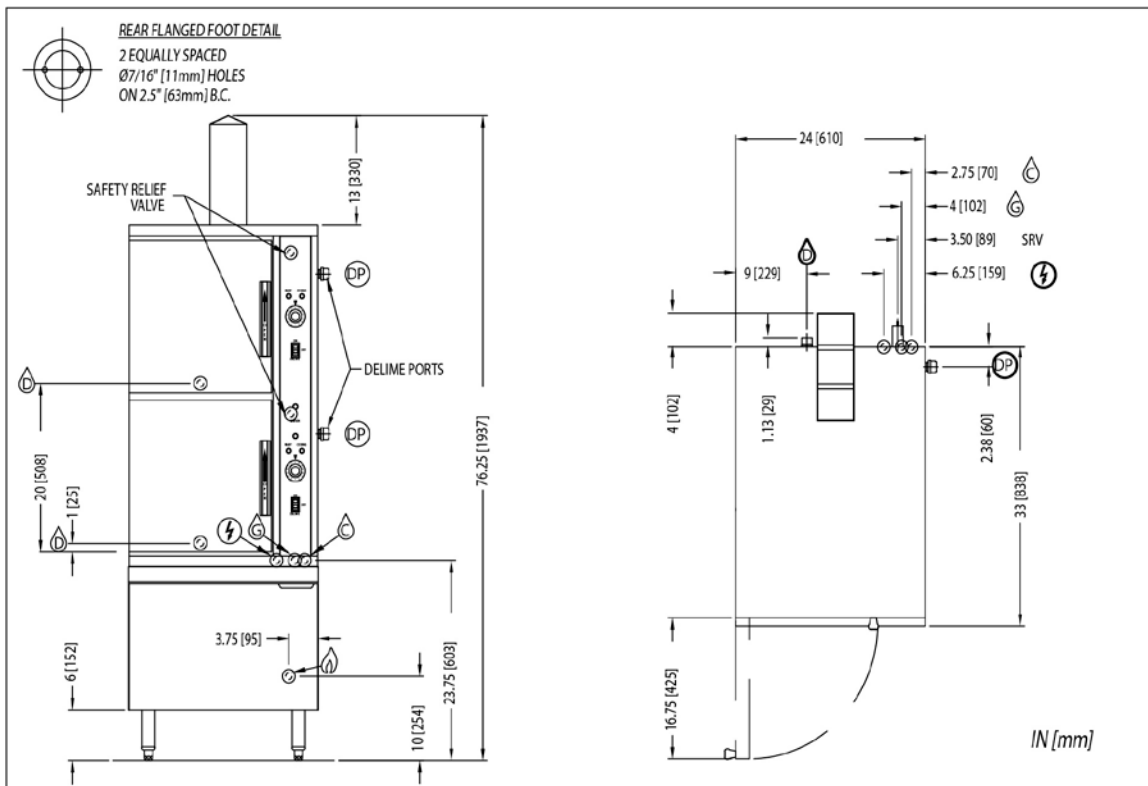

2.0 INSTALLATION

GENERAL

NOTICE: If this equipment is being installed at over 2,000 feet altitude and was not so specified on order, contact service department. Failure to install with proper orifice sizing may void the warranty.

Installation must conform with local codes, or in the absence of local codes, with the *National Fuel Gas Code, ANSI Z223.1/NFPA 54*, or the *Natural Gas and Propane Installation Code, CSA B149.1*, as applicable.

1. The appliance and its individual shut off valve must be disconnected from the gas supply piping system during any pressure testing of that system at pressures in excess of ½ psi (3.5 kPa).
2. The appliance must be isolated from the gas supply piping system by closing its individual manual shut off valve during any pressure testing of the gas supply piping system at test pressures equal to or less than ½ psi (3.5 kPa).

Electrical grounding must be provided in accordance with local codes, or in the absence of local codes, with the National Electrical Code, ANSI/NFPA 70, or the Canadian Electrical Code, CSA C22.2, as applicable.

Ventilation must be provided in accordance with local codes, or in the absence of local codes, with *ANSI/NFPA 96 Standard for Ventilation and Fire Protection of Commercial Cooking Operations*.



WARNING: Electrical grounding instructions - units equipped with a three-prong (grounding) plug for your protection against shock hazard and should be plugged directly into a properly grounded three-prong receptacle. Do not cut or remove the grounding prong from this plug. (120 volt units only).

WIRING DIAGRAM FOR APPLIANCE IS LOCATED ON RIGHT HAND SIDE PANEL OF THE COOKER CABINET.

2.1 EXHAUST FANS AND CANOPIES:

Canopies are set over ranges, ovens, kettles, etc., for ventilation purposes. It is recommended that a canopy extend 6" past appliance and be located 6' 6" from the floor. Filters should be installed at an angle of 45 degrees or more with the horizontal. This position prevents dripping of grease and facilitates collecting the run-off grease in a drip pan, usually installed with the filter. A strong exhaust fan tends to create a vacuum in the room and may interfere with burner performance or may extinguish pilot flames. Makeup air openings approximately equal to the fan area will relieve such vacuum. In case of unsatisfactory performance on any appliance, check with the exhaust fan in the "OFF" position.

2.2 WALL EXHAUST FAN:

The exhaust fan should be installed at least two feet above the vent opening at the top of the unit.

2.3 CLEARANCES:

Adequate clearance must be provided in aisle and at the side and back. Adequate clearances for air openings into the combustion chamber must be provided, as well as for serviceability for use on noncombustible floors. Minimum clearance from combustible and noncombustible construction, 3 inches on left side, 8 inches on right side and 6 inches from back.

WARNING: These procedures must be followed by qualified personnel or warranty will be voided. An open gap floor drain is required immediately below the appliance drain.

TO INSTALL:

1. Uncrate carefully. Report any hidden freight damage to the freight company immediately.
2. Set the unit in place. Be certain to maintain the minimum clearances from combustibles and non-combustibles.
3. Level appliance using spirit level. Should flanged adjustable feet be provided, anchor to floor using proper anchoring devices.
4. Seal bolts and flanged feet with Silastic or other equivalent compound.
5. Be certain to leave adequate clearances for cleaning, maintenance and service.

GAS CONNECTION:

1. The Serial and Rating Plate on the unit indicates the type of gas your unit is equipped to burn. DO NOT connect to any other gas type.
2. A ¾" NPT line is provided at rear for the connection. Each compartment is equipped with an internal pressure regulator which is set at 3.5" W.C. manifold pressure for natural gas and 10" W.C. for propane gas. Use ⅜" pipe tap on the burner manifold for checking pressure.

An adequate gas supply is imperative. Undersized or low pressure lines will restrict the volume of gas required for satisfactory performance. A steady supply pressure, between 6" W.C. and 14" W.C. for natural gas and between 11" W.C. and 14" W.C. for propane gas is recommended. With all units operating simultaneously, the manifold pressure on all units should not show any appreciable drop. Fluctuations of more than 25% on natural gas and 10% on propane gas will create problems, affecting burner operation. Contact your gas company for correct supply line sizes.

Purge the supply line to clean out any dust, dirt or other foreign matter before connecting the line to the unit. Use pipe joint compound which is suitable for use with Propane on all threaded connections. A manual gas shut off valve for each compartment is supplied with the unit.

Test pipe connections thoroughly for gas leaks.

All the connections must be checked for leaks, after the unit has been put in operation.

Use soapy water only for testing on all gases. Never use an open flame to check for gas leaks.

NOTE: If applicable, the vent from the gas appliance pressure regulator shall be installed to the outdoors in accordance with local codes or, in the absence of local codes, with the National Fuel Gas Code, ANSI Z223.1 or the Natural Gas Installation Code CAN/CGA-B149.1 or the propane installation code, CAN/CGA-B149.2, as applicable.

ELECTRICAL CONNECTION

	WARNING: Do not connect the appliance to the electrical supply until after the gas connection has been made.
---	---

120 VAC-60 Hz-Single Phase
120 VAC-60 Hz-Single Phase
120 VAC-60 Hz-Single Phase

Units with this electrical rating are factory supplied with a three-wire cord and three-prong plug which fits any standard NEMA 5-15R 125 VAC, three-prong grounded receptacle. A separate 15 amp supply is needed for each unit.

PLUMBING CONNECTIONS

	WARNING: Plumbing connections must comply with applicable sanitary, safety and plumbing codes.
---	---

Two water lines are provided, one for each compartment. Connect water supply line to the 3/8" copper tube in at the rear of the steamer. The 3/8" copper tube supplies water to both the generator tank and to condense live steam entering the drain line.

DRAIN CONNECTIONS (FIGURE 2)

The drain connection must be 1" IPS vertically down, preferably with one elbow only, and maximum length of 6 feet, piped to an open air gap type drain.

	CAUTION: In order to avoid any back pressure in the steamer, do not connect solidly to any drain connection.
---	---

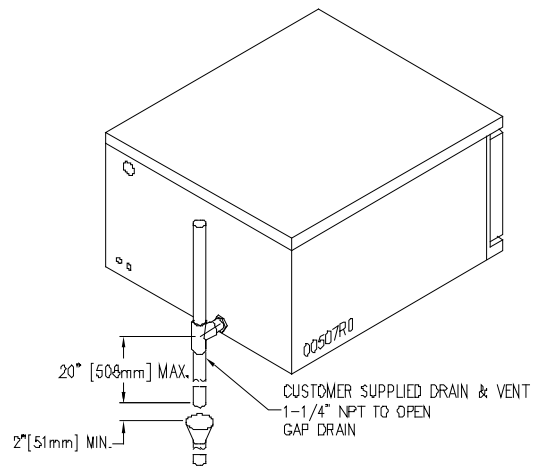

COLD WATER CONDENSER

The steamer is equipped with a cold water condenser in the rear of the cooking chamber which helps to condense the steam prior to discharge into drain. The steamer freely vents itself by the negative pressure created by the condensate water drainage. This negative pressure prevents steam leakage around the door gasket and helps draw the steam through the cooking compartment. Steam leakage at the door may indicate a plugged or improperly installed drain.

WATER CONDITIONING

It is important that the water supply connected to this steamer be softened to no more than 2.0 grains of hardness and have a pH of 6 to 7.5. This degree of hardness can be easily obtained with the use of a properly maintained water softener. The use of a water meter will determine the water consumption and when the water softener needs regeneration or recharging. Failure to comply with these water condition standards may void the warranty.

Untreated water contains scale producing minerals which can precipitate onto the surfaces in the boiler. Due to the temperatures in the boiler, the minerals can bake onto the surfaces and components. This can result in early component failure and reduced product life. Water level probes become coated with scale. Scale will bridge across the probe insulator from the metal extension which senses the water level in the boiler shell. Once this scale becomes wet, the water level control is unable to maintain the proper water level in the boiler.

STRAINERS and FILTERS will NOT remove minerals from the water.

3.0 PERFORMANCE CHECK

Once the steamer is installed and all mechanical connections have been made, thoroughly test the steamer before operation.

1. Check that proper water, drain and electrical and gas connections have been made.
 2. Turn main power switch ON. After approximately 19 minutes, the "READY" light should come on, indicating that the water temperature is 205° Fahrenheit (97° Celsius).
 3. Check that "Ignition" light comes on and cycles "ON" and "OFF".
 4. When the "READY" light comes on, set timer to the "5 minute" position. With door open, observe that no steam is entering the compartment and that the "COOKING" light is OFF.
 5. Close compartment door. The COOKING light should now be illuminated and steam should be heard entering the compartment after about 45 seconds.
1. Ensure that water from cold water condenser is flowing through the drain line.
 2. Open compartment door and observe that steam supply to chamber is cut off. "READY" light should again come on as "COOKING" light goes "OFF".

Close compartment door and let cooking cycle finish. When the timer returns to "0" position, a buzzer will sound signaling the end of the cooking cycle. Buzzer must be manually turned off by setting the timer to its "OFF" position.

4.0 OPERATION INSTRUCTIONS



WARNING: The steamer and its parts are hot. Use care when operating, cleaning or servicing the steamer. The cooking compartment contains live steam. Stay clear when opening door.

Your steamer has been factory set when “ON” to maintain water temperature during the READY phase at approximately 205° Fahrenheit (97° Celsius) just below water boiling point.

CONTROLS

Ready Pilot Light

When lit, indicates steam chamber has reached 205° Fahrenheit (97° Celsius) and is ready for the cooking cycle.

Cooking Pilot Light

When lit, indicates that a cooking cycle is in progress.

Timer

Set the cooking time (0 to 60 minutes) - steam cooking will begin when the door is closed. The cooking cycle will be interrupted if the door is open during the cooking cycle; resume cooking by closing the door.

Main Power Switch

ON - The boiler will automatically fill and begin heating to the pre-set temperature.

OFF - The boiler will drain.

DELIME - Closes the drain valve while CLR liquid is being poured into the generator during the Delime procedure.

Ignition Light

When lit, indicates burners have been ignited and are heating the generator tank.



WARNING: In the event of main burner ignition failure, a 5 minute purge period must be observed prior to re-establishing ignition source. If so equipped, some units will automatically re-attempt ignition.



WARNING: In the event a gas odor is detected, shut down equipment at the main shut off valve and contact the local gas company or gas supplier for service.

LIGHTING

1. Ensure power, gas and water supply is on.
2. Turn power switch "ON".
3. Generator tank will begin filling with water.
4. Once water level has been reached, the ignition light should come on and remain on until ready light comes on.
5. Steamer is now ready for use.

SHUTDOWN

STAND BY

1. Set timer to "OFF" position and leave door slightly open.

COMPLETE SHUTDOWN

1. Set timer to "OFF" and turn power switch "OFF". Generator will drain automatically.
2. Turn water supply "OFF".
3. Turn gas supply "OFF".
4. Disconnect power supply.

STEAM COOKING

Your steamer efficiently cooks vegetables or other foods for immediate serving. Steam cooking should be carefully time controlled. Keep hot food holding time to a minimum to produce the most appetizing results. Prepare small batches, cook only enough to start serving, then cook additional amounts to meet demand. Separate frozen foods into smaller pieces to allow more efficient cooking.

Use a pan cover for pre-cooked frozen dishes that cannot be cooked in the covered containers in which they are packed if they require more than 15 minutes of cooking time. When cover is used, approximately one-third additional cooking time is necessary.

Cooking time for frozen foods depends on amount of defrosting required. If time permits, allow frozen foods to partially thaw overnight in a refrigerator. This will reduce their cooking time.

PREPARATION

Prepare vegetables, fruits, meats, seafood and poultry normally by cleaning, separating, cutting, removing stems, etc. Cook root vegetables in a perforated pan unless juices are being saved. Liquids can be collected in a solid 12" x 20" pan placed under a perforated pan. Perforated pans are used for frankfurters, wieners and similar items when juices do not need to be preserved. Solid pans are good for cooking puddings, rice and hot breakfast cereals. Vegetables and fruits are cooked in solid pans in their own juices. Meats and poultry are cooked in solid pans to preserve their own juices or to retain broth. Canned foods can be heated in their opened cans (cans placed in 12" x 20" solid pans) or the contents may be poured into solid pans.

PAN

The steamer compartment is designed to accept combinations of the pan of 12" x 20" (either solid or perforated) as shown on the following Table 1.

TABLE 1

DEPTH OF PAN	NUMBER OF PANS				
	SN-5G	SC-7G		SC-10G	
		Top Compartment	Bottom Compartment	Top Compartment	Bottom Compartment
1"	10	6	8	10	10
2 ½"	5	3	4	5	5
4"	3	2	2	3	3
6"	2	1	2	2	2

5.0 PERIODIC MAINTENANCE



NOTICE: As a safety precaution, disconnect the power supply during cleaning or servicing.

CLEANING

At the end of each day, or between cooking cycles if necessary:

1. Turn main power switch OFF.
2. Remove pans and racks from compartment and wash in sink.
3. Wash compartment interior with clean water.
4. Use warm soapy water with a cloth or sponge to clean exposed bead of door gasket, rinse with warm clear water and wipe with a dry cloth.

Wipe surfaces which touch door gasket with a cloth or sponge and warm soapy water, rinse with warm clear water and wipe with a dry cloth. **Do not apply food oils or petroleum solvents or lubricants directly to door gasket or surfaces which touch door gasket.**

5. Remove drain screens from inside compartment drains. Using a plastic bottle brush and mild detergent, clean inside the drain opening ensuring there is no food residue or blockage. Clean the drain screen and replace in its original position.
6. Leave door slightly open when steamer is not in use.



CAUTION: Do not use cleaning agents that are corrosive.

NOTICE: Contact the factory, the factory representative or a local service company to perform maintenance and repairs should the appliance malfunction. Refer to warranty terms.

CLEANING

Weekly, or more often if necessary:

1. Clean exterior with a damp cloth and polish with a soft dry cloth.
2. Use a non-abrasive cleaner to remove discolorations.
3. Clean around burner air mixer and orifice if lint has accumulated. Side cover must be removed to clean this area.

Monthly:

1. Clean around burner air mixers, louvered panels if grease or lint has accumulated.

Following daily and period maintenance procedures will enhance long-life for your equipment. Climatic conditions - salt air - may require more thorough and frequent cleaning otherwise the life of the equipment could be adversely affected.

It is **NOT RECOMMENDED** to use cleaning agents that are corrosive.

Use of cleaning agents that contain chloride, acids or salts which are corrosive may cause pitting and corrosion when used over a period of time; this will reduce the life of the appliance.

Should pitting or corrosion occur, this is not covered by warranty.

Follow the recommended cleaning instructions. Use a mild detergent, warm water and rinse thoroughly.

NEVER SPRAY WATER INTO ELECTRIC CONTROLS.

MAINTENANCE

STAINLESS STEEL

To remove normal dirt, grease or product residue from stainless steel, use ordinary soap and water (with or without detergent) applied with a sponge or cloth. Dry thoroughly with a clean cloth. Never use vinegar or any corrosive cleaner.

To remove grease and food splatters or condensed vapours that have baked on the equipment, apply cleanser to a damp cloth or sponge and rub cleanser on the metal in the direction of the polishing lines on the metal. Rubbing cleanser as gently as possible in the direction of the polished lines will not mar the finish of the stainless steel. **NEVER RUB WITH A CIRCULAR MOTION.**

Soil and burnt deposits which do not respond to the above procedure can usually be removed by rubbing the surface with **SCOTCH-BRITE** scouring pads or **STAINLESS** scouring pads. **DO NOT USE ORDINARY STEEL WOOL** as any particles left on the surface will rust and further spoil the appearance of the finish. **NEVER USE A WIRE BRUSH, STEEL SCOURING PADS (EXCEPT STAINLESS), SCRAPER, FILE OR OTHER STEEL TOOLS.** Surfaces which are marred collect dirt more rapidly and become more difficult to clean. Marring also increases the possibility of corrosive attack. Refinishing may then be required.

TO REMOVE HEAT TINT

Darkened areas sometimes appear on the stainless steel surface where the area has been subjected to excessive heat. These darkened areas are caused by thickening of the protective surface of the stainless steel and are not harmful. Heat tint can normally be removed by the foregoing, but tint which does not respond to this procedure calls for a vigorous scouring in the direction of the polish lines using **SCOTCH-BRITE** scouring pads or a **STAINLESS** scouring pad in combination with a powdered cleanser. Heat tint action may be lessened by not applying or by reducing heat to equipment during slack periods.

REMOVAL OF SCALE DEPOSITS

It is recommended that your steamer be delimed once a month, or more often if necessary.

Should your steamer develop a heavy build-up of lime scale deposits, use the CLR TREATMENT KIT available from your authorized servicer.

Before beginning deliming procedures, ensure that the water is not overflowing into the cooking compartment.

6.0 DELIMING PROCEDURE (For units equipped with this feature)



WARNING: Read and follow instructions on the CLR bottle. Use plastic or rubber gloves to avoid skin contact. If CLR comes in contact with skin, rinse with clean water.

1. Drain steam generator by setting power switch to “OFF”, set cooking timer to 0.
2. Turn power switch to DELIME.
3. Unscrew brass deliming cap on right side of steamer. Insert hose in hole of port. Pour 20 ounces of solution into generator slowly to avoid spillage. Remove hose. Screw deliming cap on so it seals tightly. Turn power switch to on
4. Allow steamer to remain in ready cycle for ½ hour, then turn power switch “OFF” and allow generator to drain.
5. Flush cycle. Turn power switch to “ON”. When ready light comes on, switch to “OFF” to flush generator. Repeat this step three times to completely flush generator.
6. Clean exterior and interior. Use a mild solution of soap and water. Rinse with clean water. Dry with a soft cloth. **LEAVE COMPARTMENT DOOR OPEN WHEN NOT IN USE.**
7. The steamer is now ready for use. Turn off for overnight shutdown.

7.0 TROUBLESHOOTING

ADJUSTMENTS

WARNING: At least twice a year, have an authorized service person clean and adjust the unit for maximum performance.

WARNING: Adjustments and service work may be performed only by a qualified technician who is experienced in, and knowledgeable with, the operation of commercial gas cooking equipment. However, to assure your confidence, contact your authorized service agency for reliable service, dependable advice or other assistance, and for genuine factory parts.

All units are adjusted at the factory. In case of operation problems at initial installation, check type of gas and manifold pressure and compare it with information on rating plate.

TROUBLESHOOTING

Burner does not come on:

1. Gas supply to unit is "OFF".
2. Manual shut off valve is "OFF".
3. Power switch is not turned "ON".
4. Probe not sensing the water level, will not call for ignition.
5. Ignitor or ignition module not functioning.

Burner produces carbon deposits:

1. Wrong orifice size.
2. Wrong gas supply.
3. Incorrect pressure at supply.
4. Dirty primary air openings.
5. Note enough primary air.

Water flows into cooking compartment:

1. Shortage of circuit at operating probe and body.
2. Scale build-up on operating probe inside generator.
3. Water fill solenoid valve is open, plugged or defective.

These problems are an indication of severe harmful water conditions which should be corrected immediately to avoid damage to the components and performance of the steamer.

Door leaks:

1. Check for damage to door gasket.
2. Clogged compartment drain or plumbing.

Water accumulates in the compartment:

1. Compartment drain clogged.

Water flows into drain during shut down:

1. Condensate solenoid valve is not closed, check for scale or foreign particles lodged in diaphragm or core tube of valve.

Water not being supplied to generator:

1. Water supply is "OFF".
2. Supply water pressure too low.
3. Defective water fill solenoid valve.
4. Probes not sensing water, thereby not operating fill solenoid.
5. Check that drain solenoid is closed.