

SB-6SC, SB-10SC and SB-16SC

CONVECTION STEAMER ON A STEAM COIL BOILER BASE

INSTALLATION – OPERATION – MAINTENANCE

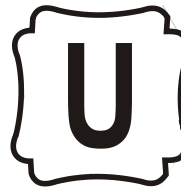

BLODGETT OVEN COMPANY

www.blodgett.com

44 Lakeside Avenue, Burlington, Vermont 05401 USA Telephone: (802) 658-6600 Fax: (802) 864-0183

S00060 Rev B (12/04)

IMPORTANT NOTES FOR INSTALLATION AND OPERATION

It is recommended that this manual be read thoroughly and that all instructions be followed carefully.



This is the safety alert symbol. It is used to alert you to potential personal injury hazards. Obey all safety messages that follow this symbol to avoid possible injury or death.



WARNING: Improper installation, operation, adjustment, alteration, service or maintenance can cause property damage, injury or death. Read the installation, operating and maintenance instructions thoroughly before installing, operating or servicing this equipment.



CAUTION: Operating, testing, and servicing should only be performed by qualified personnel.

NOTICE: Contact the factory, the factory representative or local service company to perform maintenance and repairs.





Intended for commercial use only. Not for household use.

This manual should be retained for future reference.

TABLE OF CONTENTS

DESCRIPTION	PAGE
Important Notes.....	2
Service Connections	4
Introduction	5
1.0 Installation Instructions	6
2.0 Information to Steam Fitter	8
3.0 Operating Instructions	10
4.0 Periodic Maintenance	12
5.0 Cleaning Instructions	14
6.0 Troubleshooting.....	16

SERVICE CONNECTIONS

-  ELECTRICAL CONNECTION: 1/2" conduit connection to controls. 120VAC-60Hz-1PH2 AMPS per compartment or to be as specified on data plate.
-  DRAIN: 2"IPS piped to open floor drain. No Solid Connection.
-  COLD WATER: 3/8" O.D. tubing at 25-50 PSI(170-345 kPa).
-  STEAM SUPPLY: 3/4" female pipe connection for 25-50 PSI(170-345 kPa).

WATER QUALITY STATEMENT

Water quality is the major factor affecting the performance of your appliance. If you are unsure of water quality, consult a local water treatment specialist and have the water analyzed. Your water supply must be within these general guidelines:

Total dissolved solids	Less than 60 PPM
Total alkalinity	Less than 20 PPM
Silica	Less than 13 PPM
Chlorine	Less than 1.5 PPM
pH Factor	7.0-8.5

Water which fails to meet these standards should be treated by installation of water conditioner.

FAILURE OR MALFUNCTION OF THIS APPLIANCE DUE TO POOR WATER QUALITY IS NOT COVERED UNDER WARRANTY.

* Pressure reducing valve is required if incoming pressure exceeds 50 PSI(345 kPa).

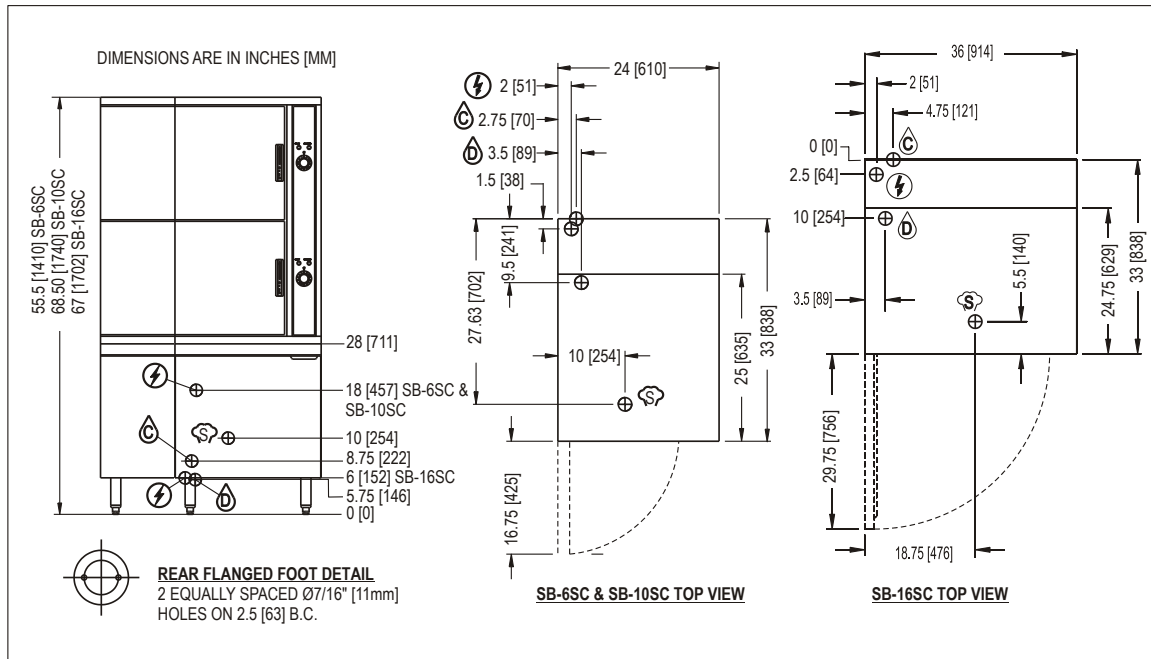

INTRODUCTION

DESCRIPTION

Models SB-6SC and SB-10SC convection steamers mounted on 24" cabinet base and a steam coil boiler. An optional 36" cabinet is available for these models. Model SB-16SC convection steamers mounted on 36" cabinet base and a steam coil boiler. All bases are designed to ASME Code and approved as a steam boiler restricted to operation at pressure not to exceed 15 psi. SB-6SC steamer has a pan capacity of 6 (2-1/2") pans. SB-10SC has a pan capacity of 10 (2-1/2") pans. SB-16SC has a pan capacity of 16 (2-1/2") pans.

BASIC FUNCTION:

The sequence of operation is as follows:

1. Turn on main power switch. Pilot light will indicate main power is on and steam generating will begin. In approximately 20 minutes, sufficient amount of pressurized steam will have been generated in the heat exchanger and ready pilot light will come on. OFF shuts off the steam supply to the boiler and opens the automatic blowdown valve, if so equipped, emptying the boiler and releasing water and steam to the drain. The manual blowdown valve will have to be opened to drain if not equipped with automatic blowdown valve.
2. Boiler pressure gauge should read 9 - 11 psi during operation, 0 psi during shutdown.
3. Compartment cooker is ready for use when READY light is on. Place pans of food to be cooked into compartment(s) and close door(s).
4. Set timer(s) to cook time desired. Cooking will commence and cooking time may be interrupted at any time by opening door(s) and resumed again by closing door(s).
5. Buzzer will sound indicating the end of the cooking cycle and that steam has stopped entering the compartment(s). The COOKING pilot will go off and the READY light will come on. Buzzer must be shut off by turning the timer(s) to its off position.

1.0 INSTALLATION INSTRUCTIONS

UNPACKING

Immediately after unpacking, check for possible shipping damage. If the appliance is found to be damaged, save the packaging material and contact the carrier within 15 days of delivery. Before installing, verify the electrical rating agrees with the specification on the rating plate.

LOCATION

Position the appliance in its installation location. Check that there are sufficient clearances to service the controls, door swing, etc. Also adequate clearance must be left for making the required supply and drain connections.

Allow enough space between any other piece of equipment or wall for service access. Service to the controls may be required on the left and/or right side panels of the cabinet.

INSTALLATION CODES AND STANDARDS

The appliance must be installed in accordance with:

In Canada:

Provincial and local codes, or in the absence of local codes, with the Canadian Electric Code, CSA C22.1 (latest edition). Copies may be obtained from the Canadian Standard Association, 178 Rexdale Blvd., Etobicoke, Ontario, Canada, M9W 1R3.

In the U.S.A.:

State and local codes, or in the absence of local codes, with the National Electrical Code, ANSI/NFPA-70 (latest edition). Copies may be obtained from The National Fire Protection Association, Batterymarch Park, Quincy, MA, 02269.

1.0 INSTALLATION INSTRUCTIONS (continued)

Ideally an exhaust system should be located directly above the appliance to exhaust steam and heat generated by the appliance.

1. Set the unit in place and level using a spirit level.
2. Ascertain that a floor drain (open gap) is convenient to the appliance drain.
3. Mark hole locations on floor through anchoring holes provided in flanged adjustable feet.
4. Remove appliance and drill holes in locations marked on floor and insert proper anchoring devices.
5. Set unit back in position and re-level left to right and front to back.
6. Bolt and anchor appliance securely to the floor.
7. Seal bolts and flanged feet with Silastic or equivalent compound.
8. Make service connections as indicated.



WARNING: Electrical and grounding connections must comply with applicable portions of the National Electrical Code and/or other local electrical codes.



WARNING: Disconnect electrical power supply and place a tag on the disconnect switch to indicate that you are working on the circuit.

Use copper wire suitable for at least 200 degrees Fahrenheit (90 degrees Celsius). The steamer must be grounded. The wiring diagram is located on the inside right hand panel as you face the steamer.

2.0 INFORMATION TO STEAM FITTER

Assuming availability of 30 psi supply steam pressure immediately to the appliance, then pipe sizes of ½" or ¾" or 1" will deliver respectively 90, 165 or 385 lbs. of steam per hour to the appliance Heat Exchanger. From the foregoing to use ½" pipe line would most likely prove inadequate.

An extremely important consideration is the pressure drop that will occur through the steam supply line from its point of origin to the appliance. The greater the length of piping and number of valves and elbows, the greater will be the pressure losses.

Consider a pressure drop of 1 (one) psi for each straight length of pipe equivalent to 120 diameters of that pipe. Thus, a 1" pipe having a straight length of 120" (10 feet) is equivalent to 120 diameters of that pipe and will have a pressure loss of 1 psi through that pipe.

Example:

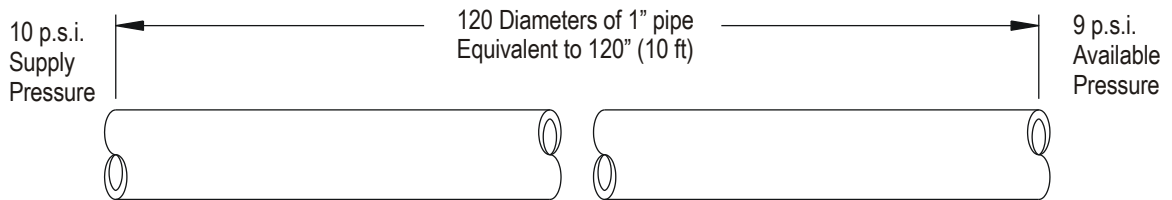

- Note, in ¾" pipe size, that a Standard 90° Elbow and Angle Valve and a Globe Valve are equivalent to 1.8 feet, 10 feet and 18 feet respectively of straight pipe.

Similarly, in a 1" pipe size, a standard 90° Elbow and Angle Valve and a Globe Valve are equivalent to 2.2 feet, 12 feet and 23 feet respectively of straight pipe.

Example:

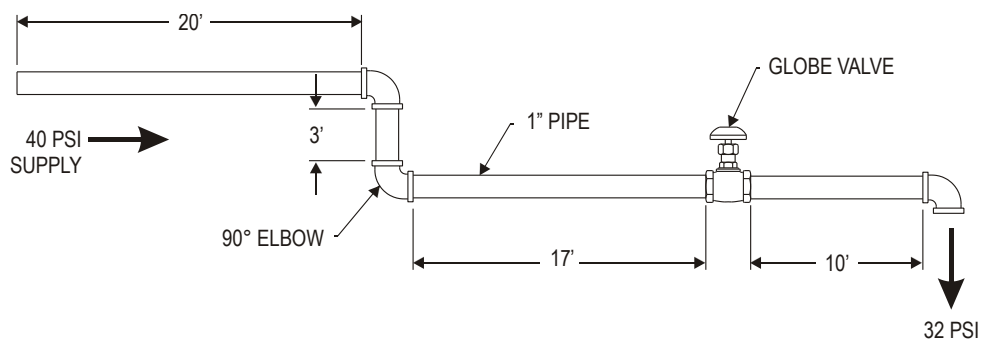

Total of above = 20 + 2.2 + 3 + 2.2 + 17 + 23 + 10 + 2.2 = 79.6 feet. Since each 10 feet is equivalent to 1 psi pressure loss, 79.6 feet is equivalent to approximately 32 psi from an original Boiler supply of 40 psi.

It is suggested that, wherever possible, the steam supply line to the appliance is a separate line from the steam source. If the appliance must be supplied from a line supplying other appliances, the pipe sizes and pressure will have to be verified. Further, during idle periods, when the steam in the supply line is not in use, water will form from condensed steam in the supply line. It is advisable to prevent water pockets from forming in the steam line and impeding the steam flow when it is required. Therefore, the steam supply line should be installed level or run slightly downwards towards the appliance. Install a Ball Float Trap near the appliance to drain out water (condensed steam) from the line to assure clean dry steam to the appliance.

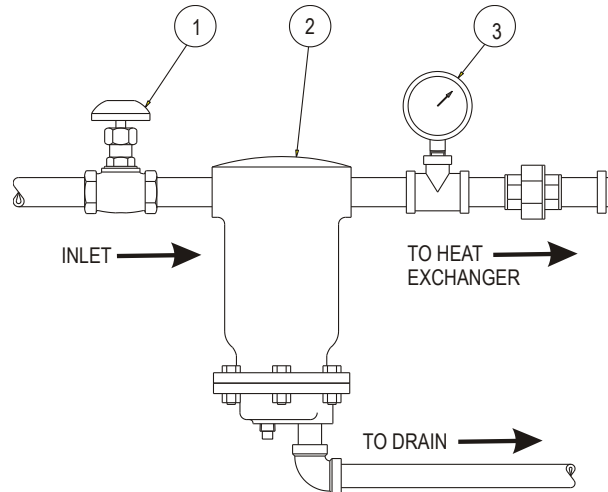

EXHAUST HOOD

An exhaust system should be located directly above the boiler to exhaust steam and heat generated by the boiler.

PLUMBING CONNECTIONS

	WARNING: Plumbing connections must comply with applicable sanitary, safety, and plumbing codes.
---	--

Water Supply Connection

The incoming cold water supply connection, at the rear of the boiler cabinet, requires 3/8" tubing and water pressure of 25 - 50 psig. A manual shut-off valve must be provided convenient to the boiler; this valve should be open when the boiler is in operation.

Drain Connection

The boiler drain (2" IPS) should be piped to a floor drain near the boiler. There should be no solid drain connection; an "open gap" between the boiler and the floor drain is required.

3.0 OPERATING INSTRUCTIONS

START UP INSTRUCTIONS

Turn on water and steam supply to appliance. Open cabinet door and turn on Power Switch. Pilot light will come ON and steam generating will begin. In approximately 20 minutes, sufficient amount of pressurized steam will have been generated in the heat exchanger. The appliance is now ready for steam generation.

SHUT DOWN

Turn off power switch, open manual drain valve. If unit is equipped with automatic blowdown valve, it will open and drain exchanger. Steam valve will close cutting off supply to exchanger.

COOKER SECTION

	CAUTION: Live steam and accumulated hot water in the compartment may be released when the door is opened.
---	--

Start-up procedures for your steamer must be completed once daily prior to operation (see instruction plate or above for boiler start up procedures).

With ready pilot light on, preheat steamer compartment for one minute when the steamer is to be first used for the day or whenever the compartment is cold.

1. Close compartment doors and set timer to "1 minute".
2. When buzzer sounds, set timer to the "OFF" position.
3. Steamer is now ready for cooking.
4. With cooking compartment preheated and ready pilot light on, place pans of food to be cooked into compartment and shut door.
5. Set timer to cooking time desired. Cooking cycle may be interrupted at any time by opening door and resumed again by closing door.
6. When buzzer sounds, it indicates the end of the cooking cycle and that no more steam is entering the compartment. Cooking pilot light will go off and ready pilot light will come on. Buzzer must be shut off by turning the timer to its off position.

3.0 OPERATING INSTRUCTIONS (Continued)



CAUTION: An obstructed drain can cause personal injury or property damage.

Frequently check that the compartment drain and plumbing is free of all obstructions. Never place food containers, food or food portion bags in the cooking compartment in such a way that the compartment drain becomes obstructed.

Each compartment is equipped with a removable drain screen. Frequently check the drain screen for accumulation of food particles. Should food particles accumulate against, or clog the drain screen, remove it, clean it thoroughly and then replace it in its original position.

SHUT DOWN

1. To shut down cooking compartment, set timers to their OFF position and leave doors slightly open.
2. At the end of the day, the steam supply must be shut off. Open the door of cabinet base and turn off power switch. Open manual drain valve. If unit is equipped with automatic blowdown valve, it will open and drain the boiler.



CAUTION: If steam supply does not shut off during blowdown, immediately discontinue use of appliance and call for service.

4.0 PERIODIC MAINTENANCE



CAUTION: Protect yourself. When flushing control, hot water and steam will flow out of the drain.

Be sure to flush your boiler water level control daily. Failure to follow this procedure can cause the control to malfunction resulting in serious boiler damage.

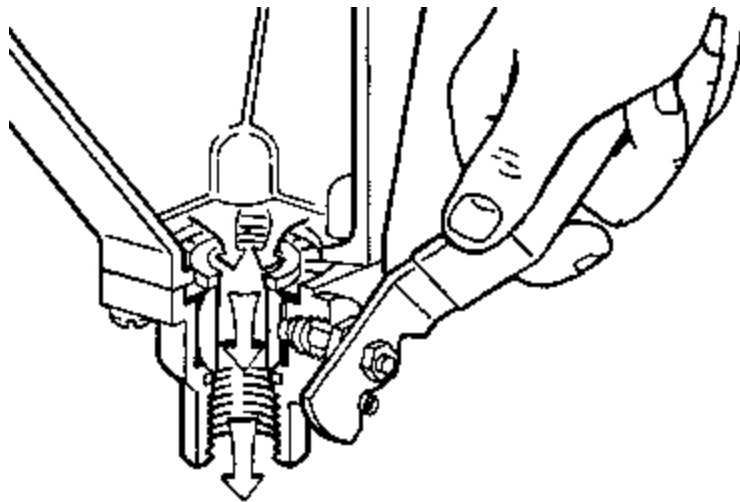

The Boiler Water Level Control installed on your boiler requires periodic maintenance. As boiler water circulates into the float chamber, sand, scale and other sediment may be deposited in the float chamber. While the chamber has been designed with a large accumulation bowl, it is necessary to flush the sediment from the chamber by blowing down the control so that the accumulation of sediment does not interfere with the movement of the float in the control. Control must be flushed at least once a day.

When flushing control, note water level in gauge glass, allow the boiler to fill if necessary, and also to come up to temperature.

Before flushing control, note that water level in gauge glass is within operating range and the boiler pressure is at least 6 psi. While the boiler is being operated, open blowdown valve at bottom of control by rotating the handle counterclockwise about 1/4 turn to fully open the valve. Opening the blowdown valve also checks the cut-off operation. Float should drop shutting steam off, hot water and steam will flow out the drain flushing away sediment.



CAUTION: If steam supply does not shut off during blowdown, immediately discontinue use of appliance and call for service.

Continue draining water for about fifteen (15) seconds, from control until water is clean. Manually close valve. Recheck gauge glass. If water level has dropped significantly, wait for the boiler to restore water level and pressure and repeat if necessary.

1. Water level control should be opened daily to blowdown sediment and scalant.
2. Observe that the water in gauge glass is clean and clear. Extreme murkiness in water indicates inadequate water quality.
3. Safety valve should be tripped during operation once a week to assure that it functions properly.
4. Keep all exposed cleanable areas of unit clean at all times.



CAUTION: Disconnect the power supply during cleaning or servicing.

5.0 CLEANING INSTRUCTIONS

	Never spray water into electric controls.
---	--

	CAUTION: Do not use cleaning agents that are corrosive.
---	--

	CAUTION: Live steam and accumulated hot water in the compartment may be released when the door is opened.
---	--

1. Keep exposed cleanable areas of unit clean at all times.
2. Thoroughly wash oven cavities, door liners, and pan racks at the end of each day or as required with a mild detergent and water to prevent bacterial growth and odours.
3. Remove drain screens from inside compartment drains. Using a plastic bottle brush and mild detergent, clean inside the drain opening ensuring there is no food residue or blockage. Clean the drain screen and replace in its original position.
4. Wash gasket sealing surface with mild detergent to remove harmful food acids and rinse.
5. Water level control should be opened daily to blow down sediment and scalant.
6. Observe that the water in gauge glass is clean and clear. Extreme murkiness in water indicates inadequate water quality.
7. Safety valve should be tripped during operation once a week to assure that it functions properly.
8. De-scaling is based on water quality and usage.

	CAUTION: Take extra caution when blowing down water level control or tripping safety valve as extreme hot water and live steam are present.
---	--

5.0 CLEANING INSTRUCTIONS (Continued)

DESCALING BOILER



CAUTION: Improper use of this procedure may damage your appliance!

1. With Generator tank empty, close manual blowdown valve.

If appliance is equipped with Automatic Blowdown, turn water supply OFF to appliance. Turn power switch ON, this will energize and close blowdown valve.
2. For appliance on 24" Cabinet, remove union fitting at connection to base of water level control and generator tank.

For appliance on 36", 48" etc. cabinet, remove 3/4" pipe cap from fitting located at top front of generator tank.
3. Insert appropriate hose or tube through opening in generator tank and pour in (1/2) half U.S. gallon of CLR Descaling Solution.
4. Replace 3/4" pipe cap OR union fitting.
5. Open water supply to appliance allowing water to fill Generator tank to required level. On appliances with Manual Blowdown, turn ON power switch, Boiler will fill to the required level.
6. Let appliance cycle, allow two hours for descaling and cleaning. **DO NOT TURN STEAM ON.**
7. Open both the blowdown and water level control valves for complete drainage and then close both valves.

On appliances equipped with Automatic Blowdown, turn OFF power switch and open water level control valve, this will allow complete drainage. Once drained, close water level control valve.
8. Turn appliance switch ON. When generator tank is completely filled, turn power switch OFF, this will rinse and drain Generator Tank. Appliances with Manual Blowdown Valve must be opened to drain.
9. Complete Step 8 twice to assure boiler is completely rinsed.
10. Appliance is now ready for use.

6.0 TROUBLESHOOTING

NOTICE: Contact the factory, the factory representative or local service company to perform maintenance and repairs. Refer to warranty terms.

DOOR LEAKS

1. Check for damage to door gasket.

WATER ACCUMULATES IN THE COMPARTMENT

1. Compartment drain screen clogged. Remove and clean thoroughly and then replace.

WATER NOT BEING SUPPLIED TO HEAT EXCHANGER

1. Water supply is "OFF".
2. Defective water fill solenoid.
3. Water level control clogged or defective, unable to operate fill valve.
4. Check drain valve is closed. Also check that water level control valve is closed.
5. Supply water pressure too low.

AUTOMATIC BLOWDOWN VALVE DOES NOT DRAIN

1. Defective Blowdown valve.
2. Heat exchanger build up of scalant clogging drain lines and valve.

HEAT EXCHANGER ACHIEVES PRESSURE SLOWER THAN NORMAL

1. Heavy build up of lime on heat exchanger tubes.
2. Steam supply pressure too low.

SAFETY VALVE BLOWS

1. Defective safety valve.
2. Pressure too high. Pressure switch requires adjustment (lower) or may be defective.

TO CALIBRATE PRESSURE SWITCHES

NOTE: Pressure switches are factory set. Calibration is only required if pressure switches are replaced or if adjustment is required.

Pressure switch range is from 1 to 15 psi.

Adjust all settings to maximum on high signal adjustment screw on pressure switches.

Adjust in the following sequence:

- High limit pressure switch.
- Override pressure switch.
- Operating pressure switch.
- Turning screw clockwise to increase, counterclockwise to decrease pressure.
- Use relief valve to release pressure from boiler for setting adjustments.

1. HIGH LIMIT PRESSURE SWITCHES

Allow pressure to build until unit shuts off. This should occur at 15 psi. Set the high signal to switch at 14.5 psi on the gauge and the low signal to 13.0 psi.

2. OVERRIDE PRESSURE SWITCHES

Allow pressure to increase to 13 psi. Set the high signal to switch at 13 psi on the gauge and the low signal to 11 psi.

3. OPERATING PRESSURE SWITCHES

Set the high signal to switch at 11 psi on the gauge and the low signal to 9 psi.

Release pressure in boiler to below 9 psi. Elements will come on. Once pressure has reached 11 psi, elements will shut off. Repeat this process several times to make sure elements come on at 9 psi and shut off at 11 psi.

Once completed, pressure switches have been calibrated.

Should your unit not have the High Limit pressure switch, start procedure at Override pressure switch.