

SPECIFICATIONS

| VOLTS | HP | AMPS SINGLE PHASE | | | REFRIGERANT | | DESIGN PRESSURE | | POWER SUPPLY CORD |
|-------|-----|-------------------|-----|------|-------------|----------|-----------------|-----|-------------------|
| | | LRA | MFS | L1-N | TYPE | QUANTITY | HIGH | LOW | |
| 115 | 1/4 | 38 | 15 | 5.5 | R-134-A | 28 OZ | 440 | 162 | NEMA 5-15P |

INSTALLATION INSTRUCTIONS REFRIGERATED COLD PAN MODEL RCP-300

CUTOUT DETAILS

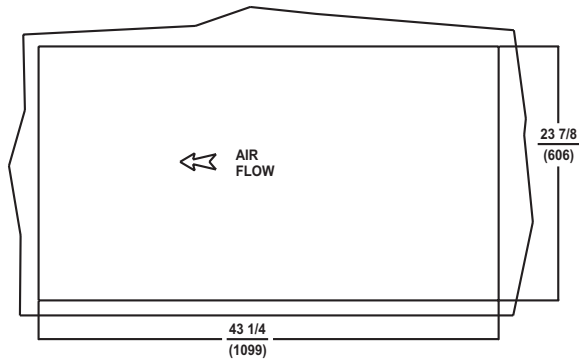

PRODUCT DIMENSIONS

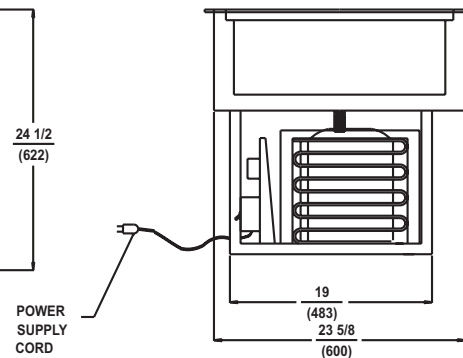
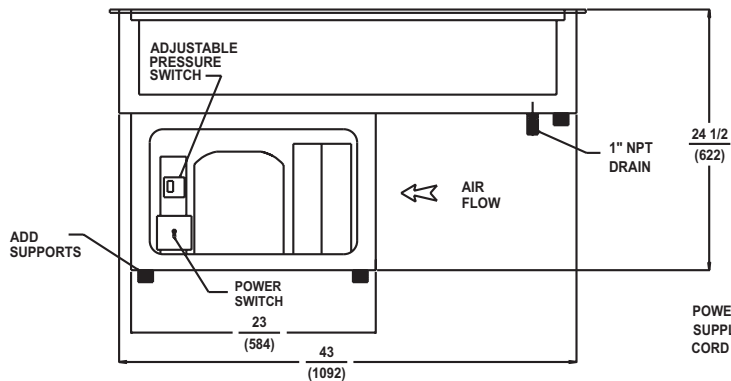
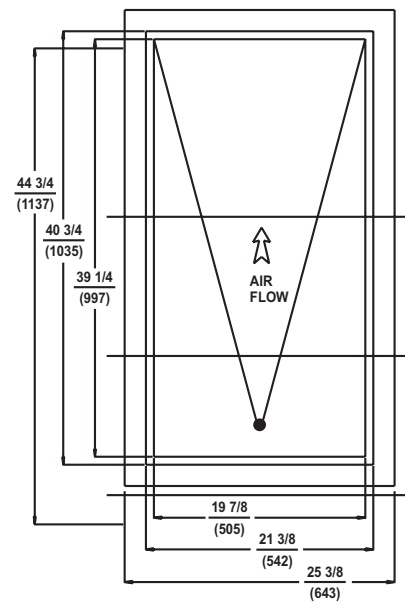

INCHES
(MM)

CLEARANCES

| MINIMUM CLEARANCE REQUIRED FROM UNIT TO THE NEAREST SURFACE. | | | |
|--|------|--------|-------|
| BACK | SIDE | BOTTOM | FRONT |
| 0 | 0 | 0 | NA |

INSTALLATION INSTRUCTIONS

INSTALLER MUST MEET CONDITIONS OF ACCEPTABILITY OUTLINED BELOW UPON INSTALLATION:

1. This unit may be installed in stainless steel, wood, Formica, or Corian tables and countertops.
2. This unit is shipped completely assembled and requires only a 15 AMP dedicated grounded outlet (NEMA 5-15R) and drain connection. Power cord and Power Switch should be accessible from the front of the unit.
3. When installing the unit it is essential to provide side openings twice the surface area of the condenser for adequate air circulation. Louvered grills with proper size may be placed in each opening.

TO INSTALL:

1. Lay out "cutout" dimensions on countertop or table.
2. Cut out hole and add stiffeners to support weight as shown. Countertop must be flat and level before installing cold pan.
3. Apply a generous bead of silicone sealant to underside of mounting flange before setting unit into cutout. Remove any excess sealant from top flange and countertop.
4. Connect 1 inch drain to drain pan or floor drain. Consult local codes for approved drain connections.

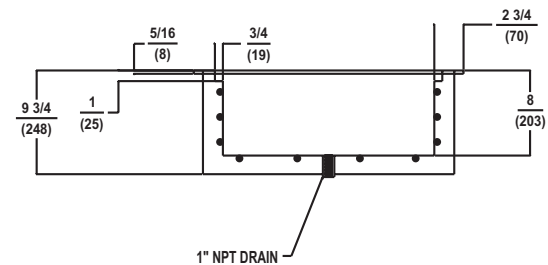

CROSS-SECTION OF COLD PAN