

## INSTRUCTIONS FOR R1499 & R1599 K.D. SUZY RACK

1. Rack will be shipped in two boxes, one with three particle board discs. The second box contains five black cutting stations, five metal dowels and all the hardware needed to build the unit.
2. To begin assembly, place the top disc (it has laminate on both sides and 20 small holes not drilled all the way through) on a hard surface with the holes facing up. Align the colored dots located on the top board with the dots located on one of the black cutting stations and as shown in Figure 1. Open the spring loaded blade and attach the cutter assembly with the hex head wood screws provided. The spring-loaded blade should open outward, see Figure 1. Attach the other four cutting assemblies the same way as the first.
3. After all the cutting stations are securely attached; begin the installation of the five clip stations using the hex head wood screws. (Figure 2)
4. After all the clip stations are attached, place the bottom disc (it has laminate on one side and 19 holes drilled all the way through) on top of the cutting stations with laminate facing down and bolt securely with 1/4-20 bolts, 1/4" keps hex nuts, and 5/16" SAE washers provided. (Figure 3)
5. Assemble the bottom paper holders and tighten securely. (Figure 4 on page 2 & Figure A shown below)
6. Next, attach the swivel plate to the non laminated side of the bottom board, aligning the four holes in the middle of the board with the slotted holes on the swivel plate. Fasten the swivel plate with four 1/4-20 bolts, 1/4" keps hex nuts, and 5/16" SAE washers. (Figure 5) **NOTE: The swivel plate is not intended to be turned until it has been fully assembled to the rack.**
7. The final step in assembling the unit is to secure the base board (it is not laminated with four holes drilled all the way through) with the four 1/4" flat-headed screws using the threaded holes on the swivel plate. The holes on the base board are counter-sunk on one side. These holes should be facing away from the swivel plate and when tightened securely the screw heads should be recessed sufficiently so when turned upright the unit stands flat.
8. Paper can now be loaded. Insert a dowel through the paper roll and then load dowel onto the bottom paper assembly. Push the top of the paper dowel into clip.

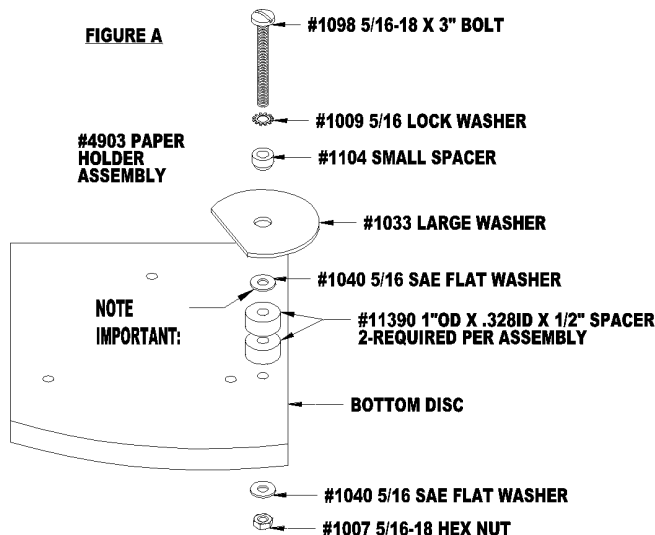

# K-D SUZY RACK

## - CLIP STYLE

# BULMAN Products, Inc.

1650 McReynolds Ave. NW  
 Grand Rapids, MI 49504-2091  
 616/363-4416, 616/363/4417, Fax 616/363-0380 www.bulmanproducts.com

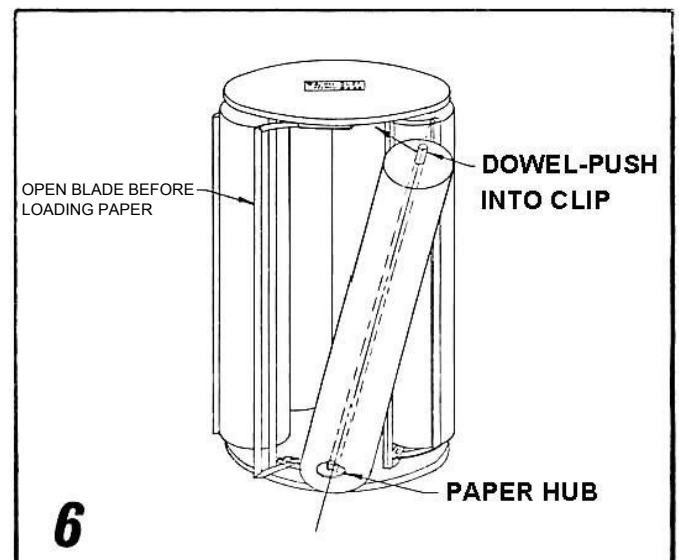
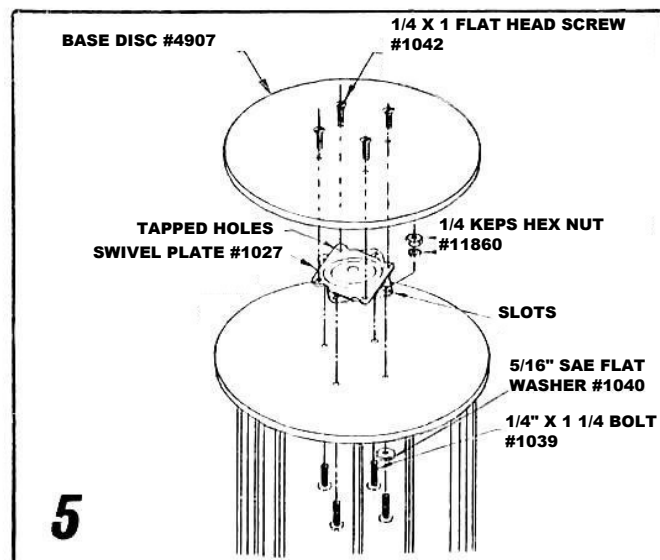
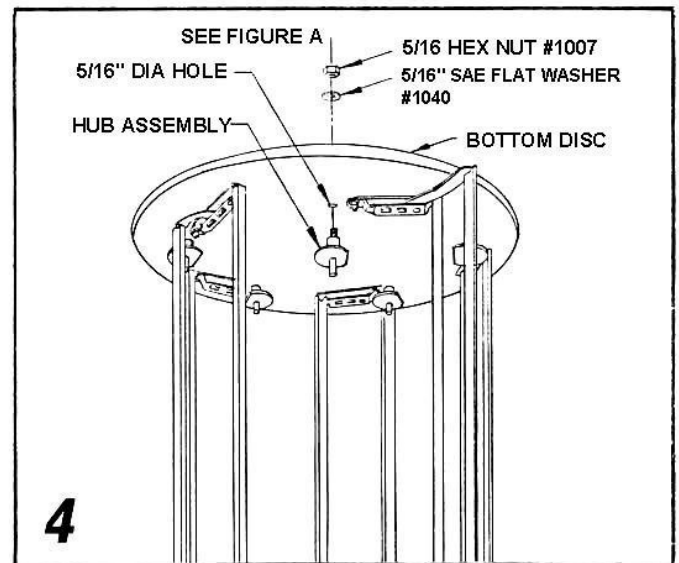
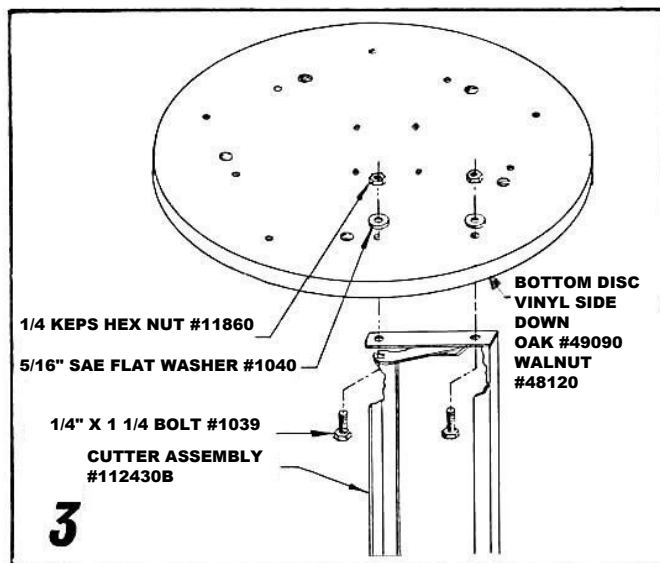
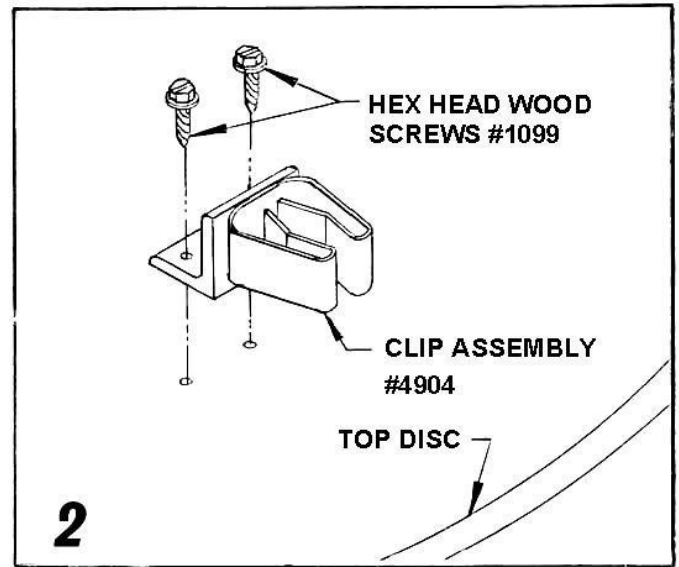
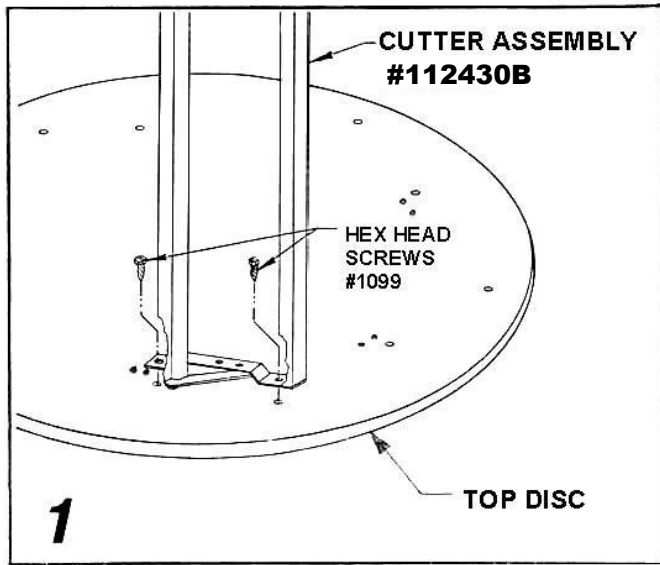

#11860 KEPS HEX NUT IS A HEX NUT WITH A FREE SPINNING LOCK WASHER ATTACHED.

1650 McReynolds Avenue, NW  
 Grand Rapids, Michigan 49504-2091  
 616/363-4416, 616/363-4417 Fax: 616/363-0380  
 www.bulmanproducts.com

**PARTS LIST  
 CLIP STYLE K.D. SUZY RACK  
 R1499 (OAK), R1599 (WALNUT)**

<u>PART NUMBER</u>	<u>QUANTITY</u>	<u>DESCRIPTION</u>
49090	1	OAK BOTTOM BOARD (WALNUT #49120)
49080	1	TOP OAK BOARD (WALNUT #49110)
49070	1	BASE BOARD
1027	1	SWIVEL PLATE
4904*	5	CLIP ASSEMBLY
4903**	5	BOTTOM PAPER HOLDER ASSEMBLY
11860	14	1/4-20 KEPS HEX NUT***
1039	14	1/4-20 X 1-1/4" HEX BOLT
1040	14	5/16" SAE FLAT WASHER
1099	20	#12 X 5/8" HEX HEAD WOOD SCREW
1042	4	1/4"-20 x 1" FLAT HEAD SCREW
112430B	5	30" SUZY CUTTER (BLACK)
120118	5	7/8" X 19 7/8" METAL DOWEL

**\*EACH 4904 CLIP ASSEMBLY CONSISTS OF:**

1202	1	BROOM CLIP
705	1	#10-24 X 1/2" SCREW
3800	1	#10-24 KEPS HEX NUT***
1203	1	CLIP ANGLE BRACKET

**\*\*EACH 4903 BOTTOM PAPER HOLDER ASSEMBLY CONSISTS OF:**

11390	2	1" LARGE PLASTIC SPACER (2 per assembly)
1008	2	5/16" SAE FLAT WASHER
1007	1	5/16-18 HEX NUT
1009	1	5/16" EXTERNAL LOCK (STAR) WASHER
1104	1	3/8" X 5/8" DIA. SMALL SPACER
1033	1	3-1/4" LARGE WASHER
1098	1	5/16-18 X 3" MACHINE SCREW

\*\*\* 11860 1/4-20 keps hex nut is a hex nut with a free spinning lock washer attached.