

OPEN BASE TABLE ASSEMBLY

1 Place the tabletop upside down on a surface that won't scratch it.

2 Insert the legs into the tabletop gussets. You may need to loosen the set screw if one struggles to go in.

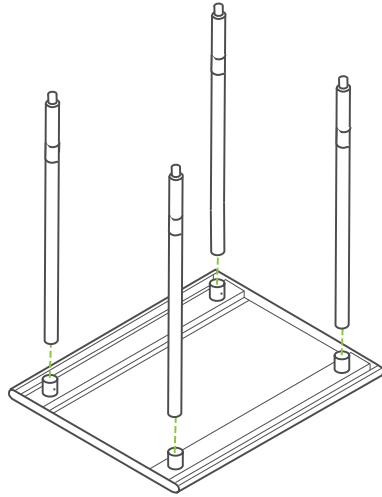

3 Partially tighten the set screws—full tightening will come later.

4 On each of the legs, mark the height where you'll be installing your braces. It should be at least 6 inches off the ground for food safety.

5 Once marked, slide the cross braces onto the legs and full tighten all the set screws.

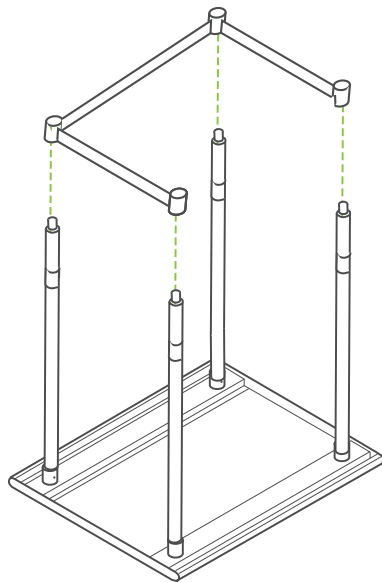

6 Adjust the feet as needed to meet your height requirements or to compensate for uneven flooring.

7 Flip the table over and peel off the protective film.

