

Proshucker® Power Shell Separator

Model #55900

Instructions for Use and Care

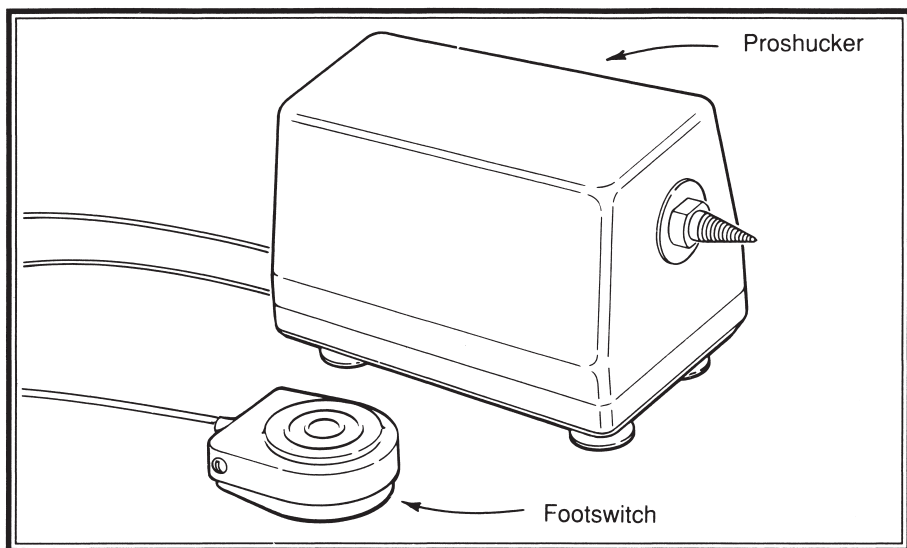

Congratulations! You have just acquired the world's first electrically powered oyster shucker. The Proshucker is a professionally engineered tool, meticulously designed for the rigors of commercial and institutional use. It turns a difficult, time-consuming and sometimes hazardous task requiring skill, into one that is easier, faster and safer. Using the Proshucker, oyster preparation can be performed by someone with little or no previous experience with a minimum of training.

The oyster shells are separated by a cone-shaped, threaded bit which literally screws itself between the top and bottom shell halves, gently forcing them apart. Then, the meat may be loosened from the shells with a dull tipped knife. A sharp-tipped knife is never needed, so hands are safe. The bit will not fracture shells or tear the oyster meat, thus resulting in higher yield. After a little practice, the average user can open as many as 10 oysters per minute.

Please read this instruction booklet in its entirety and keep it handy for future reference. Do not attempt to use the machine until you've finished reading these instructions. Also, read the product warranty statement and complete the Product Warranty/Registration Card and mail it back to the manufacturer.

— A T E N C I Ó N —

Para evitar el riesgo de daños personales, es muy importante que entienda completamente estas instrucciones. Si tiene alguna dificultad siguiendo el texto en inglés, encuentre a alguien que sepa inglés y español perfectamente, para que le ayude a traducirlo.

IMPORTANT SAFEGUARDS

• READ ALL INSTRUCTIONS

• **NEVER** immerse either the power unit or the footswitch in water or other liquid. Severe electrical shock can result.

• **CLOSELY** supervise nearby children when using Proshucker.

• **DO NOT** operate the Proshucker outdoors.

• **DO NOT** attempt to operate the Proshucker if the unit has been dropped or if power cord, power plug, footswitch or footswitch cord have been damaged. Return it for repair. (See SERVICE.) Except for the bit and splash shield, there are no user serviceable parts.

• **DO NOT** operate when wearing loose clothing or accessories (bracelet, neck chain, necktie, scarf, etc.). These could be caught by the rotating bit and cause injury. Loose hair should be pulled back and secured.

• **DO NOT** touch the threaded bit with a gloved hand when the bit is rotating. The threads may grab your glove and attempt to wrap it (and your hand) around the bit.

• **THE PROSHUCKER** is equipped with a power cord with a three-blade plug. Plug this **ONLY** into a matching 120 volt A.C. three-blade outlet. **DO NOT** cut off the third blade or attempt to use with a two-blade extension cord. If you are too far from the outlet, use a three-wire extension cord of adequate power rating (see specifications), obtainable at almost any hardware store.

• **UNPLUG** the machine when not in use, before attempting to clean or when changing bits. Pull only on the plug, never on the cord.

• **MAKE SURE** that the footswitch is not depressed before plugging-in or unplugging the power cord.

• **DO NOT** attempt to use with unauthorized attachments or for any application other than that for which the unit was designed. Such use could create a hazardous situation or cause personal injury to the user.

• **DO NOT** operate on or near hot surfaces or appliances used for cooking.

• **DO NOT** let power cord hang over edge of table or counter.

• **WHEN NOT IN USE**, store the unit in a safe place where it will not be a hazard to passers-by.

SAVE THESE INSTRUCTIONS

INSTRUCTIONS FOR USE AND CARE

ATTACHING THE BIT

The threaded bit and the round splash guard are packed with the Proshucker but not attached to it when the unit is shipped (see Figure A). The plastic splash guard is a round disc with a center hole that fits over the output shaft, behind the bit. It prevents liquids and pieces of debris from entering the Proshucker body. Slide it over the output shaft until it hits the machine housing.

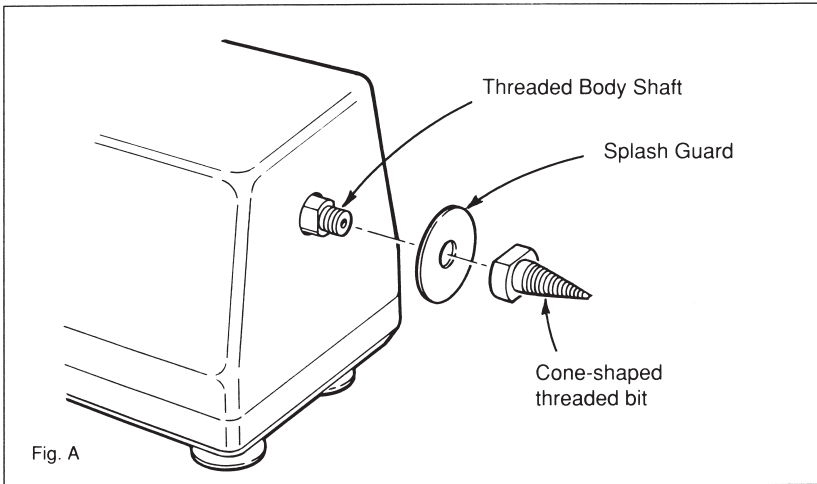

The bit has a hole on the back side, threaded to mate with the output shaft. Screw the bit onto the shaft, as far as it will go. You can just make it finger tight. It will tighten as you shuck oysters.

PICKING A WORK LOCATION

Make sure that your work location has adequate space so you can work freely and that it is close to a standard, 120 volt A.C., three-blade wall outlet. (The power cord is about six feet long.) Arrange to drape the line cord (and the extension, if one is used) where it will not interfere with your working freedom of movement, where it cannot be caught by the rotating bit and where it will not trip passers-by.

The Proshucker should be placed on a flat, non-porous counter with the bit facing away from you. Press down on the top of the Proshucker to set the suction cups.

Decide which foot you will use to operate the foot switch and put the switch on a firm or hard-surfaced floor, where it can lie flat in front of that foot. **DO NOT** place it in water or on a very wet floor.

SHUCKING OYSTERS

1. Plug the unit into the wall power outlet.

2. Note: **For best results, always work from a position that is behind the unit, with the bit facing away from you as shown in Figure B.**

Then, if you are right handed, pick up an oyster in your left hand (a glove will protect the hand from the rough oyster shell) and hold an oyster knife with your right. If you are left handed, reverse these instructions.

3. Holding the Proshucker down with the right hand, bring the oyster hinge up and onto the bit (Figure C). To find the right spot, look for a natural groove in the shell which occurs at the hinge. (The hinge is generally the pointed end of the oyster. For typical location see Figure F.) Be sure bit is between shells and in hinge before depressing footswitch.

4. Depress the footswitch. The bit will start to rotate. Applying light pressure, push the oyster into the bit. The bit will catch and pull the oyster toward it, parting the two halves of the shell. Hold the oyster tightly to prevent it from rotating with the bit. Changing the angle of the oyster while applying pressure will help the bit to catch. Do not apply heavy pressure when pushing the oyster onto the bit. This is not only unnecessary, but can be hazardous to the operator.

5. When the shells of the oyster reach the shoulder of the bit, (Figure D) release the footswitch but do not pull the oyster off the bit. With the shells spread apart, slide the knife over the meat, under and against the top shell, slicing through the adductor muscle. Remove and discard the top shell.

6. Slide the knife under the oyster meat to sever the muscle from the bottom shell as shown in Figure E. The oyster is now ready to be used or served on the half shell.

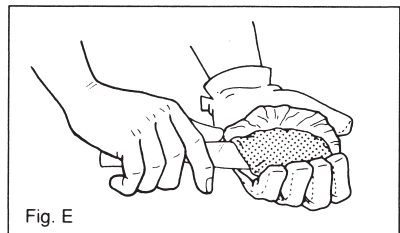
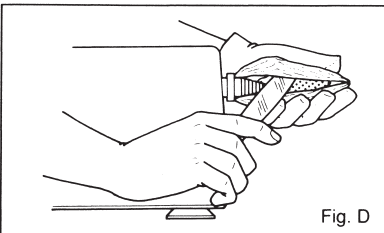
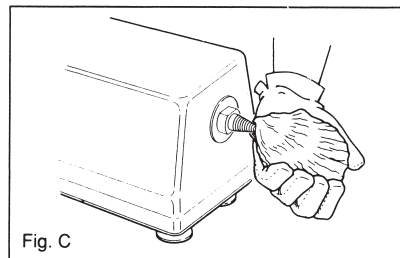
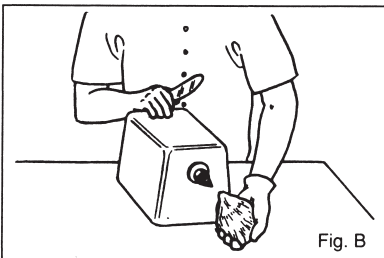

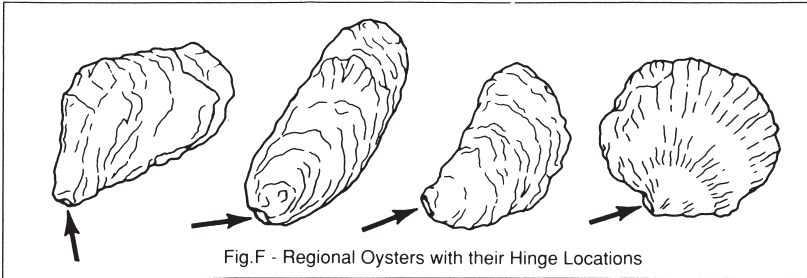

CLEANING

Proshucker should be cleaned after each day's usage. Always unplug the unit first. Then:

1. Wipe the unit down with a damp, hot soapy sponge or towel. Take care to keep water from entering the case either through the output shaft hole or the air vents in the underside of the base. NEVER immerse either Proshucker or the footswitch in water. Dry with soft towel.
2. Clean the bit. It need not be removed unless there is a large accumulation of dirt and debris behind the bit. To prevent bacterial growth, make sure that all jammed-in material is removed from the thread grooves. You can do this with a small brush. Spray with anti-bacterial solution. Dry the bit thoroughly when clean.
3. The bit may be removed to clean around the splash guard area, if necessary. To remove the bit (refer to Figure G):
 - a. Hold the Proshucker output shaft by engaging the two flats on the shaft with a 3/8" open-ended wrench. If a wrench is not available, use a pair of pliers.
 - b. Grasp the bit at the flats on the unthreaded portion (largest diameter), with a 5/8" open ended wrench. Give it a sharp, counter-clockwise (backward) turn. It then can be unscrewed easily by hand. Use a pair of pliers if no wrench is available.
4. Clean the foot pedal in the same manner as the case. Dry the pedal after cleaning.

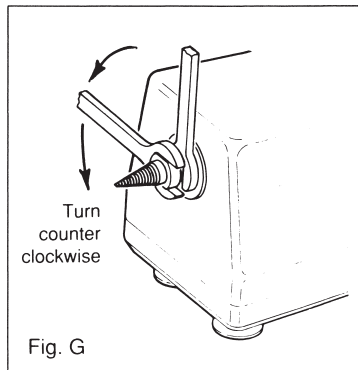

SPARE AND REPLACEABLE PARTS

The only Proshucker user-replaceable parts are the conical bit and the splash guard. While the bit is made of stainless steel, it will wear in time, with a consequent loss of shucking effectiveness. Spares may be ordered as part no. 55954. To avoid unproductive down-time, it is recommended that each user have two spare bits on hand, stored in a secure and accessible place. Spare splash guards may be ordered as part no. 45183.

Contact Nemco Food Equipment for spare parts.

PRODUCT SERVICE

The Proshucker is inherently very reliable and because of its rugged construction, should require little or no service throughout its lifetime. However, if service is ever needed, it must be performed at the factory. There are no internal user-replaceable parts. Any user attempt to effect repair may invalidate the warranty and could be dangerous.

Nemco has a staffed service department and we believe prompt service is extremely important to our customers. Therefore, we request all product service inquiries be handled in the following manner:

- (1) The end user should call Nemco Customer Service with the company name, address, phone number, model number, serial number (if applicable), Nemco Sales Order number or Dealer Purchase Order number and the nature of the problem (the "Claim Information").
- (2) The Nemco Customer Service Department will decide on the most appropriate course of action. If Nemco determines that it must inspect a product, the following procedure will be followed.

The end user will obtain a Return Goods Authorization number from Nemco Customer Service to return the product to Nemco for inspection. Please be sure to use this number on the box and on paperwork sent with the unit. Return the unit to Nemco. The Nemco Service Department will determine if the problem is covered by the foregoing warranty. If so, Nemco will repair the unit and return it to the end user. If the unit is determined not to be covered by the foregoing warranty, the dealer will be contacted to determine the next course of action.

TROUBLESHOOTING

Problem:

Motor doesn't run when footswitch is depressed.

Action:

1. Check-to see that unit is plugged-in.
2. Make sure that electrical outlet is live by trying another appliance or a lamp in the same outlet. If unit still won't work, return to Proshucker for repair. (See SERVICE, page 6)

Problem:

Motor runs but bit doesn't turn.

Action:

Internal damage has resulted either from the unit being dropped or mishandled during shipping. Return for repair. (See SERVICE, page 6)

Problem:

Rotating bit will not grab oyster

Action:

1. Make sure that tip of bit is in hinge of oyster. (See Figures, page 4.)
Note: Practice will help you to avoid incorrect bit placement. However, some raw oysters cannot be opened by any method without risk of injury. If you serve cooked oysters, these can be steamed or microwaved until they gape open.
2. Change angle of oyster - rotate oyster, tilt it up and down and/or move it side to side.
3. Bit has become dull. Replace with new bit (See page 5, no. 3 for removal instructions and page 6 for spare part ordering instructions.)

Problem:

Oyster shell breaks during opening

Action:

This can occasionally occur with a very thin shelled oyster. Because Proshucker applies equal pressure to both shells, this will happen less often than with previous manual shucking techniques.

PROSHUCKER SPECIFICATIONS:

Manufactured by:

Model: 55900

Power: 120 VAC, 60 HZ, 1 Amp or

230 VAC, 50-60 HZ, .5 Amp

Shipping Weight: 8 lbs.

NEMCO Food Equipment, Ltd.

301 Meuse Argonne

P.O. Box 305

Hicksville, OH 43526

Phone (419) 542-7751

U.S. Patent #4870719. U.S. & Foreign Pats.

PRODUCT WARRANTY

Except as otherwise provided below, Nemco Food Equipment, LLC ("Nemco") warrants, to the original user, its electrical food preparation products (other than blades and light bulbs) to be free of electrical and mechanical defects in material and workmanship under "normal use" (defined below) for the shorter of the following periods: (a) one (1) year from the date placed in service by the original user, or (b) 18 months from the date of shipment from its factory. In addition, Nemco warrants its non-electrical food preparation products (other than blades) to be free of mechanical defects in materials and workmanship under normal use for two (2) years from the date placed in service by the original user. The warranty provided for herein shall be limited to parts and labor. Any determination that a product is defective or covered by this warranty, shall be made by Nemco, in its sole discretion. The determination of whether to repair or replace a defective, covered product, or to refund the purchase price for the product, will be at Nemco's sole discretion. This warranty does not cover products used outside the United States, or damages caused by accident, misuse, negligence or any person other than Nemco, current or voltage other than stated on the appliance, fire, flood or other casualty. Any alteration to the product or unauthorized repair voids this warranty. For purposes of this warranty, the phrase, "normal use" shall mean the use of the product in connection with food in accordance with product manual accompanying the product.

Nemco shall be responsible only for repairs or replacements of defective parts performed by Nemco's authorized service personnel. Authorized service agencies are located in principal cities throughout the continental United States, Alaska and Hawaii.

THE FOREGOING WARRANTY IS EXCLUSIVE AND IN LIEU OF ALL OTHER WARRANTIES, EXPRESS OR IMPLIED. NEMCO EXPRESSLY DISCLAIMS ANY IMPLIED WARRANTY THAT ANY OF ITS PRODUCTS IS MERCHANTABLE, FIT FOR A PARTICULAR PURPOSE, OR DOES NOT INFRINGE ON THE RIGHTS OF ANY THIRD PARTY. THE FOREGOING WARRANTY, SHALL BE NEMCO'S SOLE AND EXCLUSIVE OBLIGATION. ANY PERSON'S (BUYER, USER OR OTHERWISE) EXCLUSIVE REMEDY AGAINST NEMCO, AND NEMCO'S SOLE OBLIGATION, FOR ANY AND ALL CLAIMS, WHETHER FOR BREACH OF CONTRACT, WARRANTY, TORT (INCLUDING WITHOUT LIMITATION NEGLIGENCE), OR OTHERWISE, SHALL BE LIMITED TO NEMCO REPAIRING OR REPLACING THE PRODUCT, OR, AT NEMCO'S OPTION, REFUNDING THE PURCHASE PRICE THEREFOR. IN NO EVENT SHALL NEMCO HAVE ANY LIABILITY FOR DAMAGES IN AN AMOUNT EXCEEDING THE PURCHASE PRICE OF THE PRODUCT, NOR SHALL NEMCO HAVE ANY LIABILITY FOR INCIDENTAL, SPECIAL OR CONSEQUENTIAL DAMAGES. Any person desiring to make any claim against Nemco must do so within six (6) months after expiration of the applicable warranty period, or such claim shall be forever barred.



NEMCO Food Equipment, Ltd.
301 Meuse Argonne
P.O. Box 305
Hicksville, OH 43526
Phone (419) 542-7751
FAX (419) 542-6690
www.nemcofoodequip.com