

Under Drawer

For Window Crib Model #510 & 530

Model DRW-5 (LB)

L.A. Baby Juvenile Products
 16039 Loukelton Street
 City of Industry, California 91744
 Toll free customer service: 800-584-3094
 e-mail: customerservice@lababyco.com
 www.lababyco.com

Parts List

Pieces per Unit

A - Drawer back	1
B - Drawer side - right	1
C - Drawer side - left	1
D - Drawer bottom	1
E - Drawer front	1
F - Drawer track (pre-installed)	2
G - Drawer hanger - left	1
H - Drawer hanger - right	1
I - Case track (pre-installed)	2
J - Wood screw 32 m/m	4
K - Machine bolt 20 m/m	4
L - Wood screw 13 m/m	4
M - L-Bracket	2
N - Machine bolt 45 m/m	4
O - Washer	4
P - Nut	4
Q - Allen wrench	1
R - Open end wrench	1

Care Instruction:

Your drawer may be cleaned, using a damp cloth and ordinary mild domestic detergent. Do not use abrasives or bleach.

Air dry.

Tools required: Phillips head screw driver
 Allen wrench (Included)
 Open end wrench (Included)

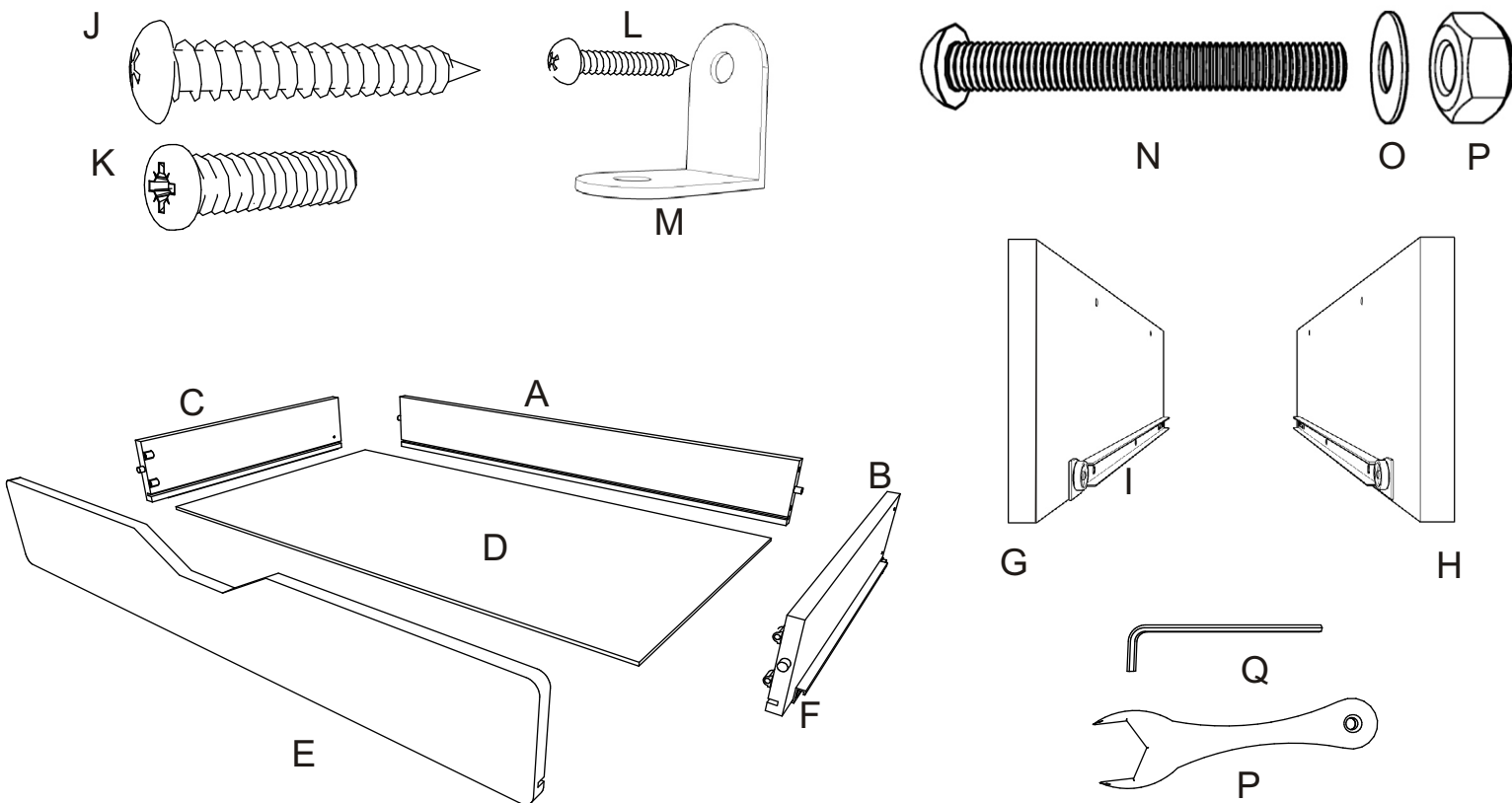

Model: DRW-5

DATE OF MFG

Made In China

Drawer Assembly

1. Align dowels of drawer back panel(A) into pre-drilled holes on left drawer side panel (C) .Make certain that the slot on bottom of the panels lines up evenly. **(Fig. 1)**
2. Insert 2 wood screws (J) into drilled holes on outside of left panel (C) .
3. Repeat this procedure for the right side panel (B). **(Fig. 2)**

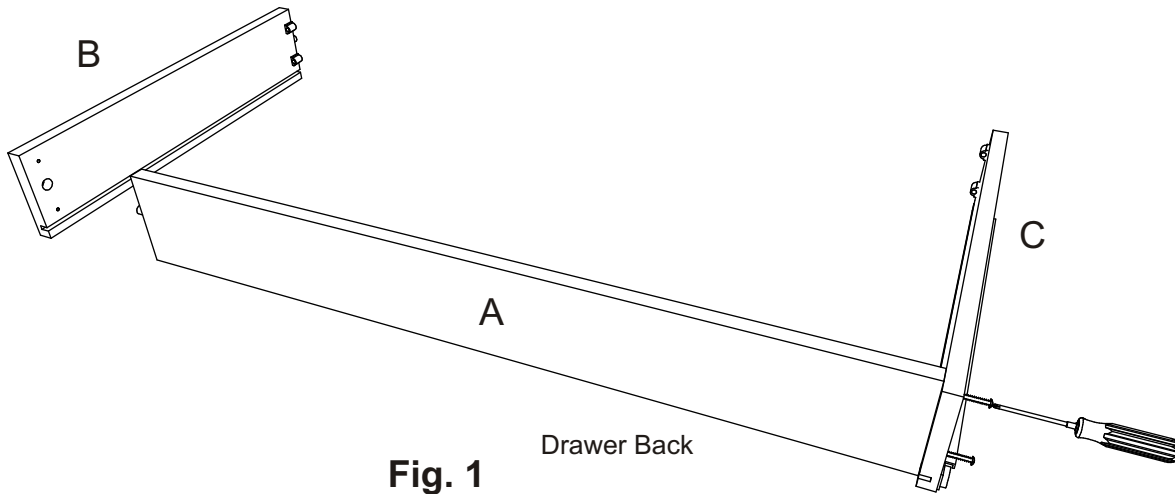

Tighten the four wood screws (K) on drawer back (clock wise) with a Phillips head screw driver **(Fig. 3)**

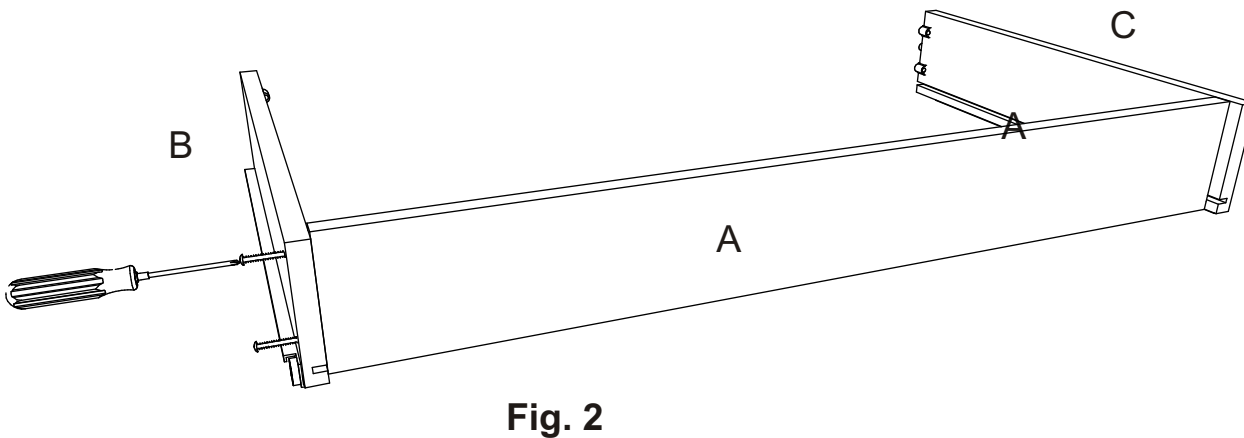

Slide the drawer bottom (D) along the slotted edges of the left and right drawer sides to the slotted edge of the drawer back. **(Fig. 3)**

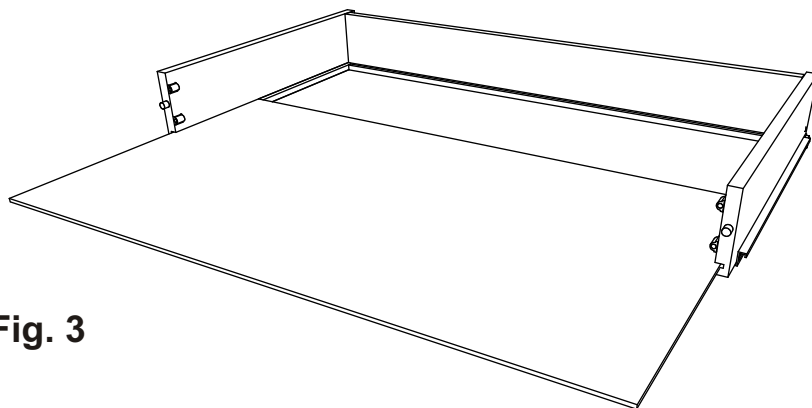

Fig. 3

Attach the drawer face (E) by aligning the drill holes on the back of the face to the plastic “bosses” on the ends of the side panels (C & B). **(Fig. 5)**

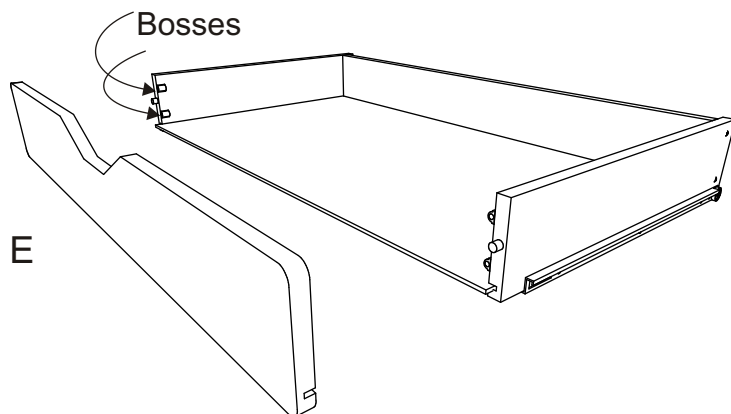
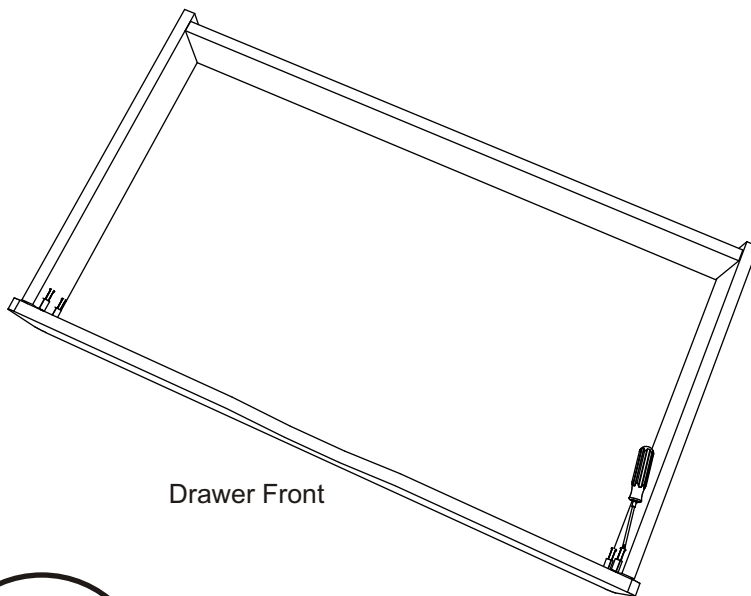

Fig. 4

Insert machine bolt (K) through lower boss and insert it into receptor on rear of face panel (E) Partially tighten the screw and repeat procedure for three remaining bosses. Complete tightening the screws with phillips head screw driver **(Fig 5)**.

Fig. 5



Attach the L-Bracket (M) onto the back of the front drawer face (E) (Note pilot holes) and onto the right and left drawer sides B & C (Note pilot holes) using the screws (L). Tighten with phillips head screw driver **(Fig 6 & 8)**

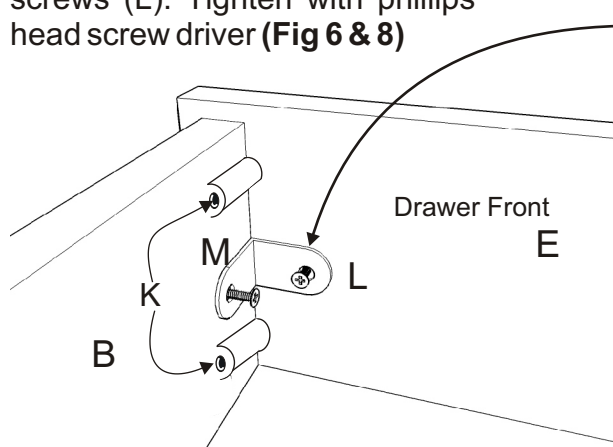

Fig. 6

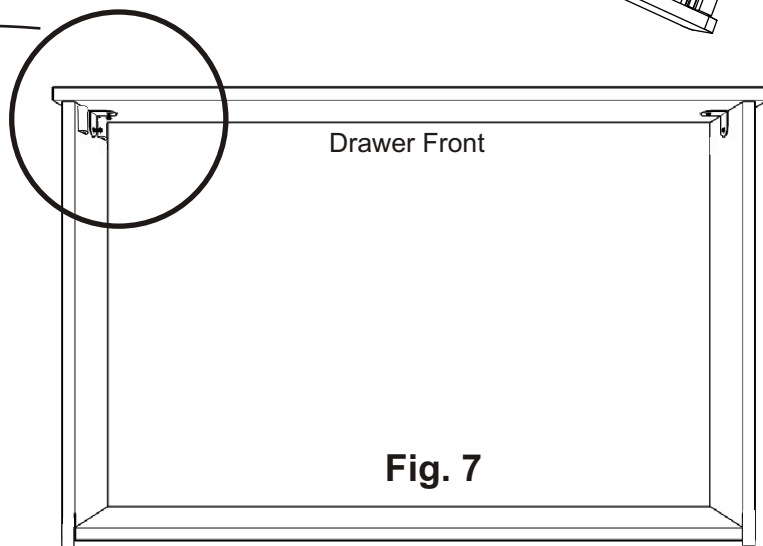
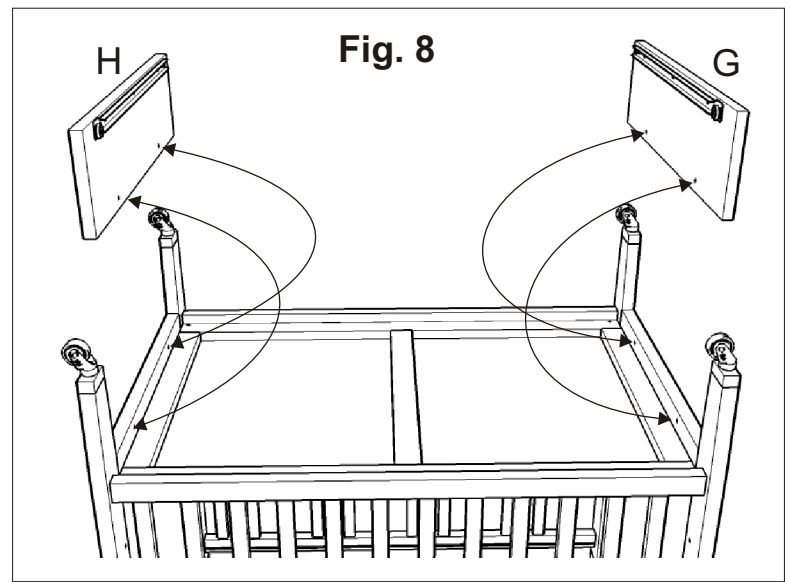

Fig. 7

Attaching the Drawer Hangers

We suggest you lay your crib up side down for easy assembly.

Place the left (G) and right (H) Drawer Hangers with the tracks facing each other along the lower horizontal of the end panels as illustrated. (Fig. 8)



Front of crib

Align the four pre-drilled holes of the Drawer Hangers and the four pre-drilled holes on the lower horizontal of the end panels. (Fig. 9)

Attach the Hangers using Bolts (N), Washers (O) and Nuts (P) on all four locations using a phillips head screw driver. Place a washer (O) next to the nut and bolt as illustrated (Fig. 9)

Make sure all four bolts and nut fasteners are tight using the allen wrench (Q) and open end wrench (P).

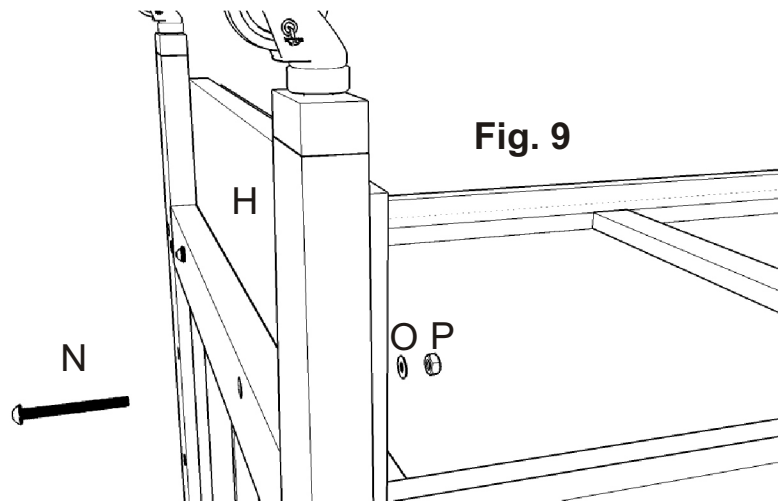

Fig. 9

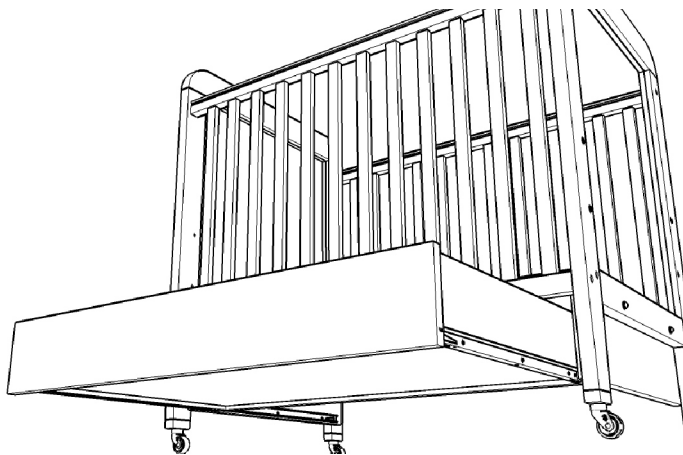

Fig. 10

Return your crib to a right-side-up position.

Gently slide in the drawer. (Fig. 10)

