

12 Hand icon. Hold for 1 minute.
Mantenga durante 1 minuto.
Maintenez pendant 1 minute.

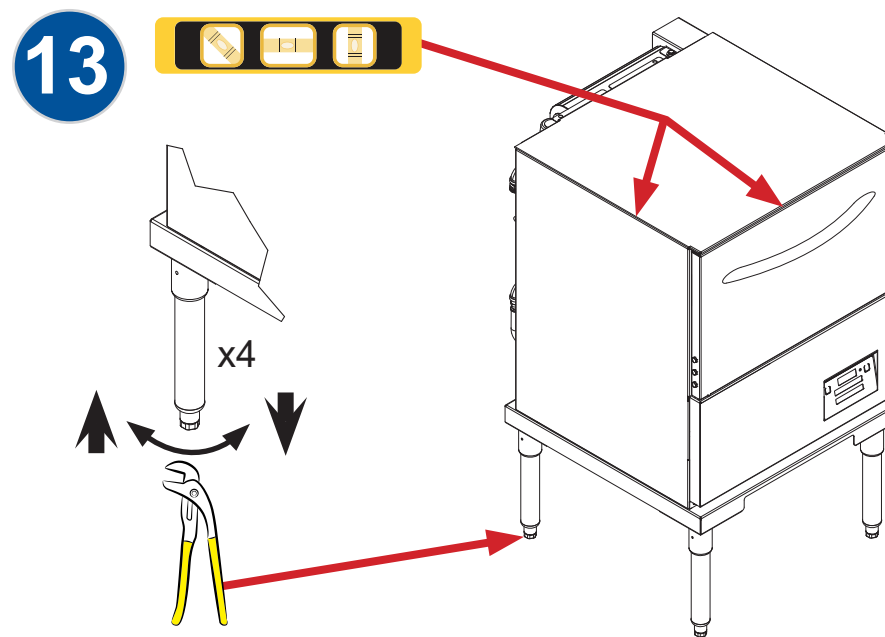

For Technical Support, call the number below.

For the Delta® HT-E-SEER Manual, scan the QR Code below or go to our website.

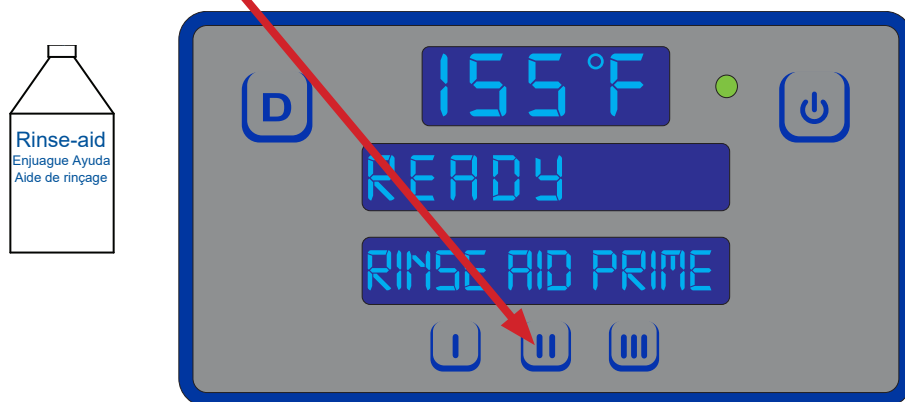

1.888.800.5672
www.jacksonwvs.com

Jackson®

Warewashing Systems

INSTALLATION QUICK GUIDE

DELTA HT-E-SEER



- = risk of electric shock
riesgo de electrocución
risque de décharge électrique
- = caustic chemicals
químicos cáusticos
produits chimiques caustiques
- = ground wire
cable a tierra
fil de terre
- = verify
verificar
vérifier
- = use fingers/hands
utilizar los dedos/manos
utilisez vos doigts/mains
- = use eyes
utiliza tus ojos
utilisez vos yeux
- = reference data plate
mire la placa de datos
regarder la plaque signalétique
- = water
agua
eau
- = not supplied
no se suministra
non fourni
- = on
encendido
allumé
- = off
apagado
éteint

