



WELLS BLOOMFIELD, LLC

10 Sunnen Drive P.O.Box 430195
St. Louis, MO 63143 USA
telephone: 314-781-2777
fax: 314-781-2714
www.wellsbloomfield.com

401

OWNERS MANUAL

**ICP-SERIES
ICE COOLED
COLD PANS**

**MODELS
ICP-100
ICP-200
ICP-300
ICP-400
ICP-500
ICP-600**

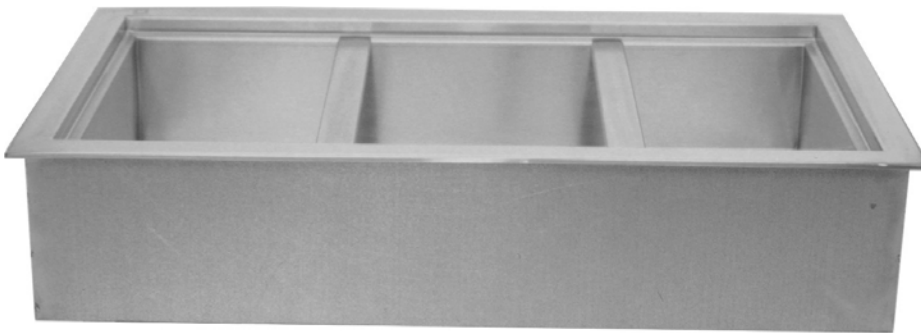

Model ICP-300

**Includes
INSTALLATION
USE & CARE**

IMPORTANT: DO NOT DISCARD THIS MANUAL

This manual is considered to be part of the appliance and is to be given to the OWNER or MANAGER of the restaurant, or to the person responsible for TRAINING OPERATORS of this appliance. Additional manuals are available from your WELLS DEALER.

THIS MANUAL MUST BE READ AND UNDERSTOOD BY ALL PERSONS USING OR INSTALLING THIS APPLIANCE. Contact your WELLS DEALER if you have any questions concerning installation, operation or maintenance of this equipment.

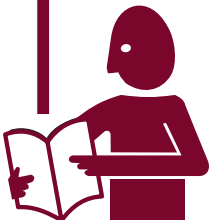

PRINTED IN UNITED STATES OF AMERICA

LIMITED WARRANTY STATEMENT

Unless otherwise specified, all commercial cooking equipment manufactured by WELLS BLOOMFIELD, LLC is warranted against defects in materials and workmanship for a period of one year from the date of original installation or 18 months from the date of shipment from our factory, whichever comes first, and is for the benefit of the original purchaser only.

THIS WARRANTY IS THE COMPLETE AND ONLY WARRANTY, EXPRESSED OR IMPLIED IN LAW OR IN FACT, INCLUDING BUT NOT LIMITED TO, WARRANTIES OF MERCHANTABILITY OR FITNESS FOR ANY PARTICULAR PURPOSE, AND/OR FOR DIRECT, INDIRECT OR CONSEQUENTIAL DAMAGES IN CONNECTION WITH WELLS BLOOMFIELD PRODUCTS. This warranty is void if it is determined that, upon inspection by an authorized service agency, the equipment has been modified, misused, misapplied, improperly installed, or damaged in transit or by fire, flood or act of God. It also does not apply if the serial nameplate has been removed, or if service is performed by unauthorized personnel. The prices charged by Wells Bloomfield for its products are

based upon the limitations in this warranty. Seller's obligation under this warranty is limited to the repair of defects without charge by a Wells Bloomfield factory authorized service agency or one of its sub-service agencies. This service will be provided on customer's premises for non-portable models. Portable models (a device with a cord and plug) must be taken or shipped to the closest authorized service agency, transportation charges prepaid, for service. In addition to restrictions contained in this warranty, specific limitations are shown in the Service Policy and Procedure Guide. Wells Bloomfield authorized service agencies are located in principal cities. This warranty is valid in the United States and Canada and void elsewhere. Please consult your classified telephone directory, your foodservice equipment dealer or contact:

Wells Bloomfield, LLC
10 Sunnen Dr., P.O.Box 430129 St. Louis MO 63143 USA
phone (314) 781-2777 or fax (314) 781-2714

for information and other details concerning warranty.

SERVICE POLICY AND PROCEDURE GUIDE and ADDITIONAL WARRANTY EXCLUSIONS

1. Resetting of safety thermostats, circuit breakers, over load protectors, and/or fuse replacements are **not** covered by this warranty unless warranted conditions are the cause.
2. All problems due to operation at **voltages or phase other than specified on equipment nameplates** are **not** covered by this warranty. Conversion to correct voltage and/or phase must be the customer's responsibility.
3. All problems due to **electrical connections not made in accordance with electrical code requirements and wiring diagrams** supplied with the equipment are **not** covered by this warranty.
4. Replacement of items **subject to normal wear**, to include such items as knobs, light bulbs; and, normal maintenance functions including adjustments of thermostats, adjustment of micro switches and replacement of fuses and indicating lights are **not** covered by warranty.
5. Damage to electrical cords and/or plug due to exposure to excessive heat are **not** covered by this warranty.
6. Full use, care, and maintenance instructions supplied with each machine. Noted maintenance and preventative maintenance items, such as servicing and cleaning schedules, are customer responsibility. Those miscellaneous adjustments noted are customer responsibility. Proper attention to preventative maintenance and scheduled maintenance procedures will prolong the life of the appliance.
7. Travel mileage is limited to **sixty (60) miles** from an Authorized Service Agency or one of its sub-service agencies.
8. All labor shall be performed during regular working hours. Overtime premium will be charged to the buyer.
9. All genuine Wells replacement parts are warranted for ninety (90) days from date of purchase on non-warranty equipment. This parts warranty is limited only to replacement of the defective part(s). **Any use of non-genuine Wells parts completely voids any warranty.**
10. Installation, labor, and job check-outs are **not** considered warranty and are thus **not** covered by this warranty.
11. Charges incurred by delays, waiting time or operating restrictions that hinder the service technician's ability to perform service are **not** covered by warranty. This includes institutional and correctional facilities.

SHIPPING DAMAGE CLAIM PROCEDURE

NOTE: For your protection, please note that equipment in this shipment was carefully inspected and packaged by skilled personnel before leaving the factory. Upon acceptance of this shipment, the transportation company assumes full responsibility for its safe delivery.

IF SHIPMENT ARRIVES DAMAGED:

1. **VISIBLE LOSS OR DAMAGE:** Be certain that any visible loss or damage is noted on the freight bill or express receipt, and that the note of loss or damage is signed by the delivery person.
2. **FILE CLAIM FOR DAMAGE IMMEDIATELY:** Regardless of the extent of the damage.

3. **CONCEALED LOSS OR DAMAGE:** if damage is unnoticed until the merchandise is unpacked, notify the transportation company or carrier immediately, and file "CONCEALED DAMAGE" claim with them. This should be done within fifteen (15) days from the date the delivery was made to you. Be sure to retain the container for inspection.

Wells Bloomfield cannot assume liability for damage or loss incurred in transit. We will, however, at your request, supply you with the necessary documents to support your claim.

TABLE OF CONTENTS

WARRANTY	xi
SPECIFICATIONS	1
FEATURES & OPERATING CONTROLS	2
PRECAUTIONS & GENERAL INFORMATION	3
AGENCY LISTING INFORMATION	3
INSTALLATION	4
OPERATION	5
CLEANING INSTRUCTIONS	6
PARTS & SERVICE	9
CUSTOMER SERVICE DATA	9

INTRODUCTION

Thank You for purchasing this Wells Bloomfield appliance.

Proper installation, professional operation and consistent maintenance of this appliance will ensure that it gives you the very best performance and a long, economical service life.

This manual contains the information needed to properly install this appliance, and to use and care for the appliance in a manner which will ensure its optimum performance.

SPECIFICATIONS

MODEL	VOLTS 1Ø	WATTS	AMPS	POWER SUPPLY CORD
Model ICP-100 thru ICP-600 contain no electrical components				

Refer to *INSTALLATION INSTRUCTIONS* packaged with each unit for cutout dimensions and other installation details

FEATURES & OPERATING CONTROLS

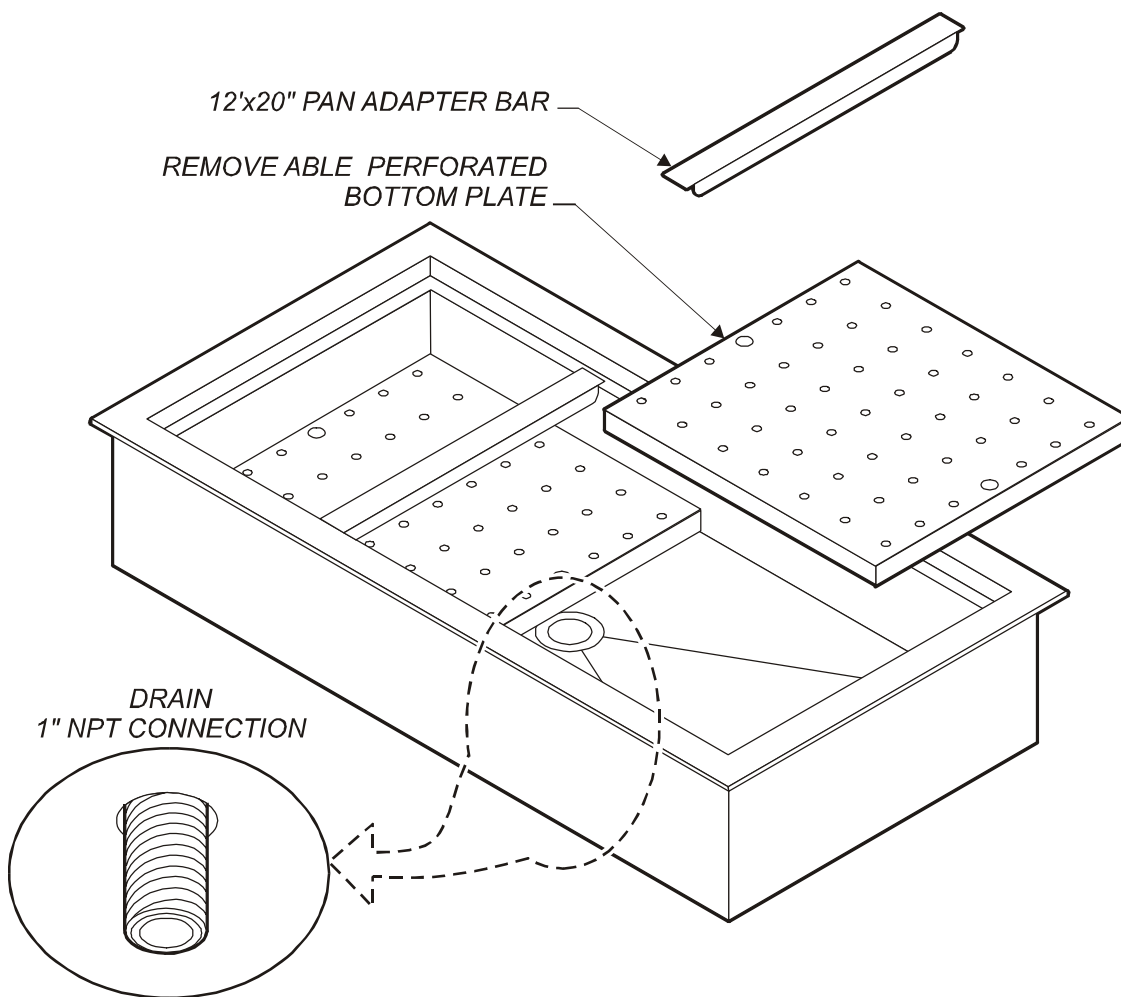

PRECAUTIONS AND GENERAL INFORMATION

This appliance is intended for use in commercial establishments only.

This appliance is intended to contain an ice bed for holding pre-chilled food at temperature food for human consumption. No other use is recommended or authorized by the manufacturer or its agents.

This appliance is NOT approved for holding potentially hazardous foods. Potentially hazardous foods must not be held in this appliance.

Operators of this appliance must be familiar with the appliance use, limitations and associated restrictions. Operating instructions must be read and understood by all persons using or installing this appliance.

Cleanliness of this appliance is essential to good sanitation. Read and follow all included cleaning instructions and schedules to ensure the safety of the food product.

Any procedure which requires the use of tools must be performed by a qualified technician.

This manual is considered to be a permanent part of the appliance. This manual and all supplied instructions, diagrams, schematics, parts breakdown illustrations, notices and labels must remain with the appliance if it is sold or moved to another location.

This appliance is made in the USA. Unless otherwise noted, this appliance has American sizes on all hardware.



CAUTION: FOOD SAFETY

This appliance has been evaluated for sanitation by NSF International. It has not been performance tested for potentially hazardous foods. DO NOT hold potentially hazardous foods in this appliance.

AGENCY LISTING INFORMATION

This appliance is NSF Standard 2 Listed.



INSTALLATION

NOTE: DO NOT discard the carton or other packing materials until you have inspected the appliance for hidden damage and tested it for proper operation. Refer to **SHIPPING DAMAGE CLAIM PROCEDURE** on the inside front cover of this manual.

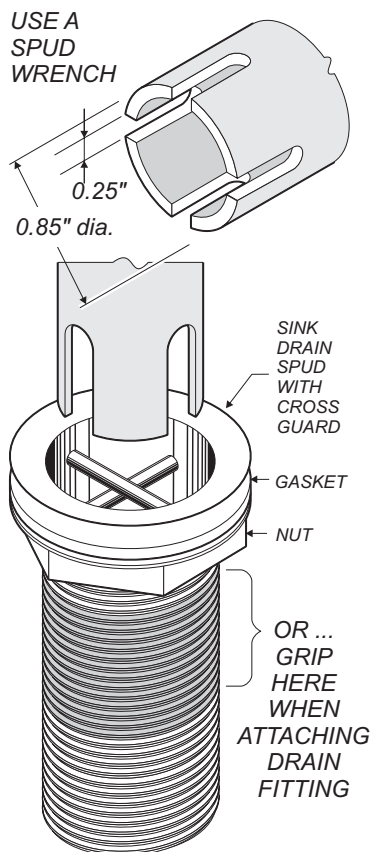

UNPACKING & INSPECTION

Carefully remove the appliance from the carton. Remove all protective plastic film, packing materials and accessories from the Appliance before connecting electrical power or otherwise performing any installation procedure.

Carefully read all instructions in this manual and the *Installation Instruction Sheet* packed with the appliance before starting any installation.

Read and understand all labels and diagrams attached to the appliance.

Carefully account for all components and accessories before discarding packing materials. Store all accessories in a convenient place for later use.

COMPONENTS (quantities vary by model)
Perforated Bottom Plate
Adapter Bar

INSTALLATION

Refer to the *Installation Instruction Sheet* packaged with each appliance for cutout dimensions and other installation details.

Counter top must be flat and level. Install supports, reinforcements and/or stiffeners as necessary in order to maintain counter flatness when the appliance is fully loaded.

Apply a generous bead of food-grade silicone sealant to underside of mounting flange before setting unit into cutout. Remove any excess sealant from counter top promptly.

Connect the drain pipe to an approved drain. Consult local codes for approved drain configurations.

IMPORTANT:

DO NOT allow the sink drain spud to turn during installation. Hold the spud with an appropriate cross-guard-style spud wrench, or carefully grip the center threaded portion with a strap wrench or slip-joint pliers to immobilize the drain spud during drain fitting installation. DO NOT grip the drain spud nut or gasket.

Refer to Cleaning Instructions (page 6). Clean the appliance and components thoroughly before use.

SETUP

Be sure main pan is drained and clean. If the unit has been equipped with a drain valve, be sure the valve is open.

Set perforated bottom plates in place. Flanges go down so that a 1" gap is maintained the plate and the bottom of the pan for drainage.

Pour a layer of fresh shaved ice over the bottom pan, Ice should be maintained at a depth of 1" - 2".

Install pan adapters as required.

USE

Set pans of PRE-CHILLED product in place. Multiple pans must be supported by the pan adapters.

DO NOT place food products directly into the ice pan or ice bed. Place the food in 12 x 20 insets, then place the insets into the ice cooled pan

Preserve the life of the ice bed by keeping a 12 x 20 pan or other appropriate cover in each position.

ALTERNATE USE

Fill the iced pan to within 1" of the rim.

For such presentations as buffet-style salads and the like, embed smaller containers of pre-chilled product in the ice bed. DO NOT place food products directly into the ice pan or ice bed.

Check the condition of the ice bed often. Refresh the ice bed if it becomes contaminated with spillage.

**CAUTION:
FOOD SAFETY**

DO NOT hold potentially hazardous foods in this appliance.

**CAUTION:
FOOD SAFETY**

DO NOT place food products directly into the ice pan or ice bed. Place pre-chilled product in insets, then place the insets into the ice cooled pan.

IMPORTANT:

Be sure to maintain the ice bed during use. Ice bed must be maintained at a depth of 1" - 2".

NOTE:

Stir product occasionally to maintain temperature and to prevent bottom freezing.

CLEANING INSTRUCTIONS

DAILY CLEANING INSTRUCTIONS

PREPARATIONS: Turn ice from iced pan.
Remove any insets, pans and/or adapter tops (if used).

FREQUENCY: Minimum - daily.

TOOLS: Mild Detergent
Plastic Scouring Pad
Clean Cloth or Sponge
Food-Grade Silicone Sealant

1. a. Wipe entire unit down using a clean cloth or sponge and mild detergent.
 - b. Use a plastic scouring pad to remove any hardened food particles
IMPORTANT: DO NOT use steel wool for cleaning.
 - c. Rinse by wiping with a clean cloth or sponge dampened with clear water.
 - d. Wipe entire unit with a clean cloth or sponge dampened with sanitizing solution.
 - e. Allow to air dry.
-
2. Inspect flange-to-counter seal. Reseal with food-grade silicone sealant if necessary.

Procedure is complete

NOTES

PARTS & SERVICE

DESCRIPTION

PART NO.

ADAPTER BAR FOR 12x20 PANS

22106

PERFORATED BOTTOM PLATE(S)

ICP-100 (1 pc)

22107

ICP-200 (1 pc)

22108

ICP-300 (2 pc)

22109

ICP-400 (2 pc)

22110

ICP-500 (2 pc)

22111

ICP-600 (3 pc)

22112

IMPORTANT: Use only factory authorized service parts and replacement filters.

For factory authorized service, or to order factory authorized replacement parts, contact your Wells authorized service agency, or call:

Wells Bloomfield, LLC
10 Sunnen Dr., P.O.Box 430129
St. Louis MO 63143 USA

Service Dept.
phone: (314) 781-2777
fax: (314) 781-2714

Service Parts Department can supply you with the name and telephone number of the WELLS AUTHORIZED SERVICE AGENCY nearest you.

CUSTOMER SERVICE DATA

please have this information available if calling for service

RESTAURANT _____ LOCATION _____

INSTALLATION DATE _____ TECHNICIAN _____

SERVICE COMPANY _____

ADDRESS _____ STATE _____ ZIP _____

TELEPHONE NUMBER (____) _____ - _____

EQUIPMENT MODEL NO. _____

EQUIPMENT SERIAL NO. _____

VOLTAGE: N/A



Wells Bloomfield proudly supports CFESA
Commercial Food Equipment Service Association

SERVICE TRAINING - QUALITY SERVICE



CUSTOMER SATISFACTION



WELLS BLOOMFIELD, LLC
10 Sunnen Drive P.O.Box 430195
St. Louis, MO 63143 USA
telephone: 314-781-2777
fax: 314-781-2714
www.wellsbloomfield.com

PRINTED IN UNITED STATES OF AMERICA