

500664 - 2 Piece Lid
(011700 center lid)

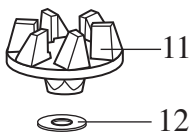

013304
NSF Sseal



WARING COMMERCIAL®

FMB148 /discontinued
Fiber Mania Blender

SMB15
Smooth Operator Blender

SMB15C /discontinued
Smooth Operator Blender with Extra Container

SMB15S
Sysco Groovie Smoothie Blender

SMC15 /discontinued
Smooth Operator Blender /CSA

SGM18 /discontinued
Smooth Operator Blender /Gold Metal

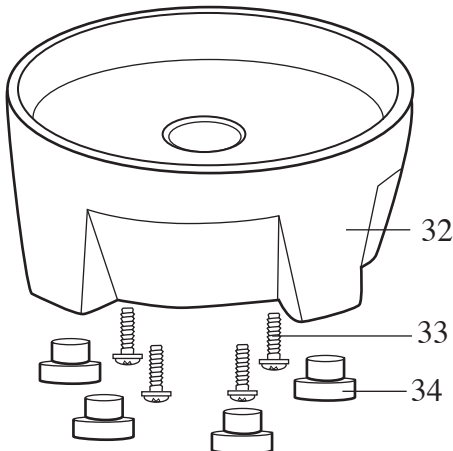
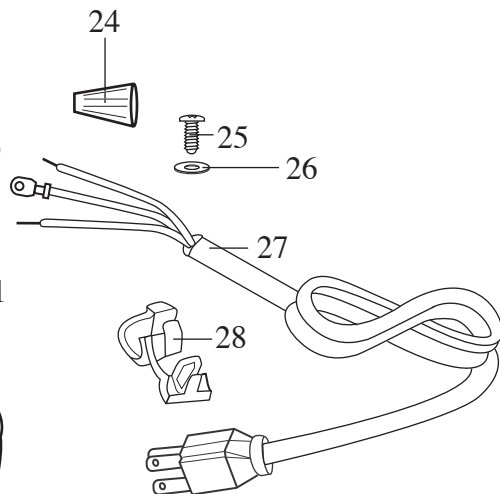
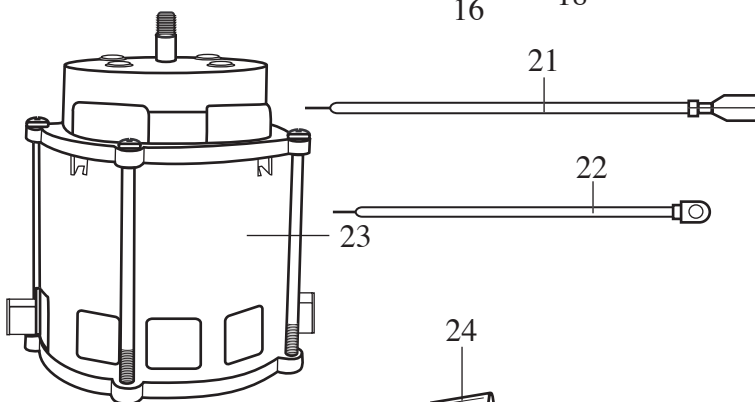
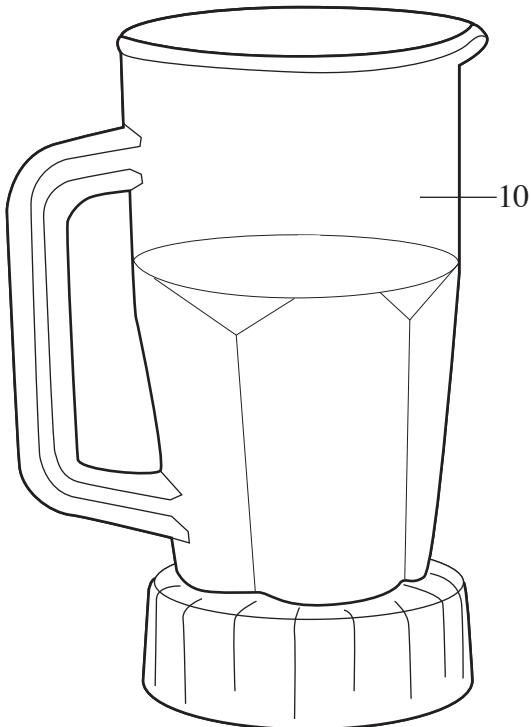
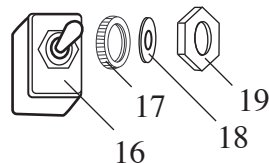
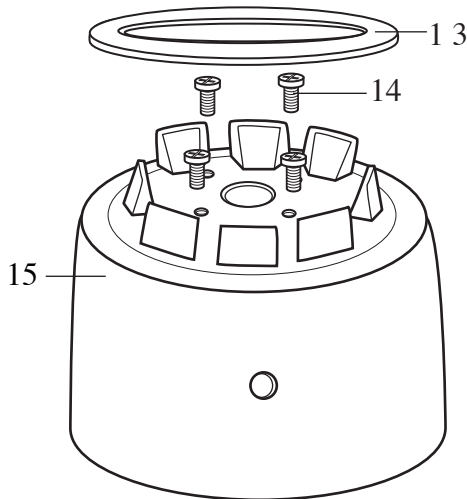
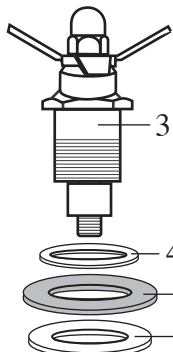

503154 (current production)
502589 (2nd generation & older units)
Container with Blending Assy.

503173 (current production)
501832 (2nd generation & older units)
Blending Assy.

Unit Information

8.5 Amps - 1 1/2 HP (current production)
7.5 Amps - 1 HP (2nd generation & older units)

Catalog	Old Model #	New Model #
FMB148	37BL78	
SMB15	39BL23	HGBPWT4
SMB15C	39BL30	HGBPWT4
SMB15S	39BL33	HGBPWT4
SMC15	39BL28	HGBPWT4
SGM18	39BL38	



Illustration #	Part #	Description
1	011700	Center Lid for FMB148, SMC15, SGM18
	003146	Center Lid for SMB15, SM15C, SMB15S
2	013442	Outer Lid / vinyl
3	503153	Blade Assy.
4	009724	Washer / nylon
5	003537	Washer / stainless steel 2 Req.'d
6	003509	Washer / neoprene-rubber 2 Req.'d
7	009780	Hex Nut
8	003507	Washer / stainless steel
9	014014	Coupling / wagon wheel
10	019560	Container / 48 oz. polycarbonate
11	018999	Coupling / SMB15, SMB15C, SMB15S 2 Req.'d
12	026413	Washer Cap (<i>current production & 2nd & 3rd generation</i>)
	003507	Washer (<i>older units</i>)
13	017777	Cushion Ring
14	007558	Screw 4 Req.'d
15	015377-01	Top Housing white
16	026800	Switch (<i>current production & 2nd generation</i>)
	012698	Switch / toggle (<i>3rd generation & older units</i>)
17	014603	Locking Ring
18	014604	Lock Washer
19	016236	Hex Nut
20	019937	Housing Seal
21	501232	Lead
22	501658	Lead / green-yellow
23	028156	Motor
24	009051	Wire Nut 2 Req.'d
	012409	Crimp Connector 2 Req.'d for SMC15
25	002436	Screw / ground wire
26	002943	Washer / ground wire
27	003565	Cord Set (<i>current production & older units</i>)
	500830	Cord Set (<i>2nd generation & 3rd generation</i>)
28	007556	Strain Relief

Catalog	Old Model #	New Model #
FMB148	37BL78	
SMB15	39BL23	HGBPWT4
SMB15C	39BL30	HGBPWT4
SMB15S	39BL33	HGBPWT4
SMC15	39BL28	HGBPWT4
SGM18	39BL38	

Waring Factory Service Center
 314 Ella T. Grasso Ave.
 Torrington, CT 06790
 Tele. 1-800-269-6640
 Fax 860-496-9017
 www.waringproducts.com

Illustration #	Part #	Description
29	025662	Baffle (current production, 2nd & 3rd generation)
	013365	Baffle (older units)
30	008324	Gasket
31	013963	Screen (current production, 2nd & 3rd generation & older SMC15)
32	014012	Bottom Housing
33	017239	Sems 4 Req.'d
34	004090	Foot 4 Req.'d
35	003553	Top End Bell
36	007557	Screw 2 Req.'d
37	500584	Field / ALL older units Except SMC15)
	500714	Field / SMC15
38	012369	Nut 2 Req.'d
39	500828	Armature
40	003555	Brush & Spring 2 Req.'d
41	013368	Bottom End Bell



018577 Name Plate /FMB148



026060 Name Plate /SMB15, SMB15C, SMC15
(current production, 2nd & 3rd generation)



023274 Name Plate /SMB15S



019955 Name Plate /SMB15, SMB15C, SMC15
(older units)

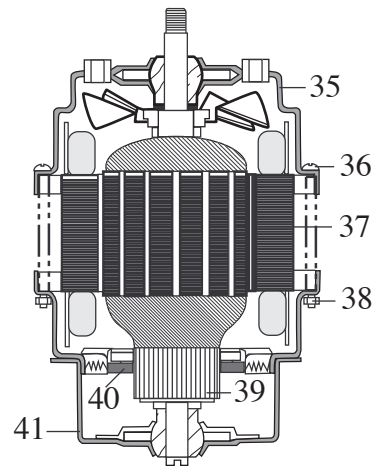

701191 Motor *Obsolete* Use **028156**
Limited Availability of Parts

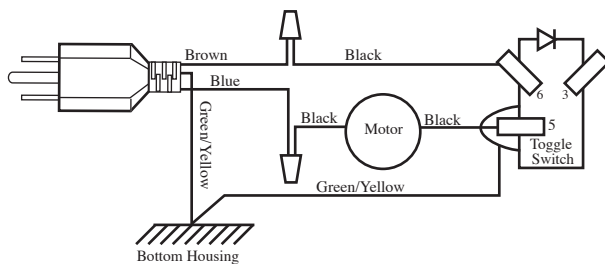

Wiring Diagram (older units)

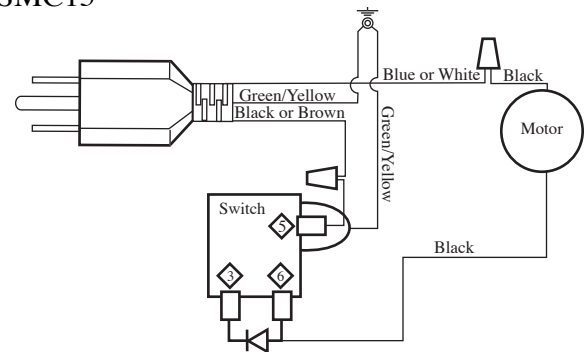

Wiring Diagram (current, 2nd & 3rd generations)

Items Not Shown

- 500455 - Lead with Diode - 003262 (older units)
- 023390 - Name Plate /Gold Metal Smooth Operator