



MMB145

Margarita Madness™ Blender with 2 Toggle Switches

Unit Information

60Hz – 13 Amps
2 HP Motor
48 oz. BPA-Free Unbreakable Container

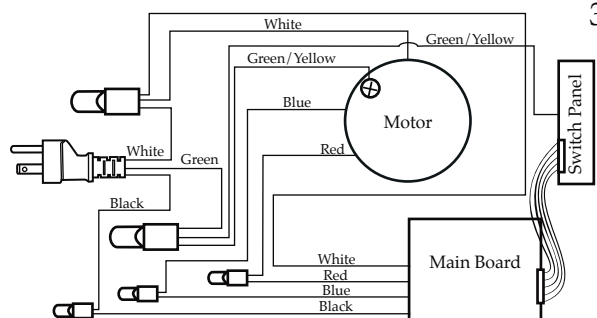

Wiring Diagram

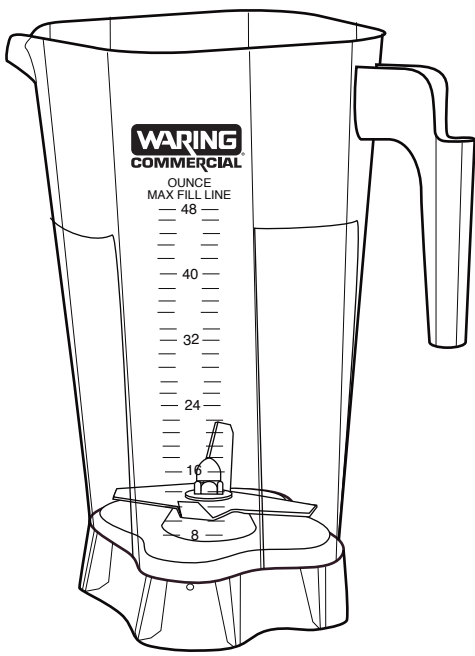
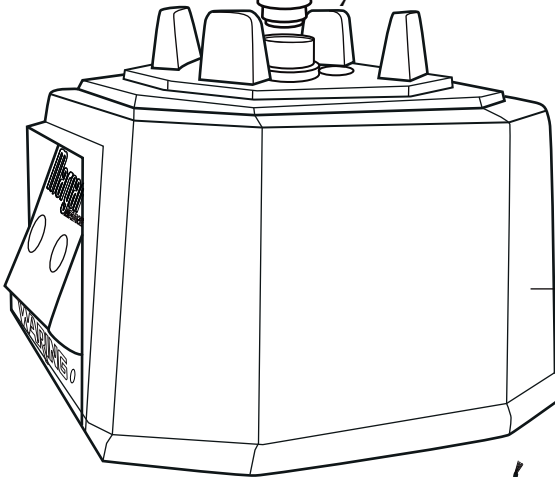
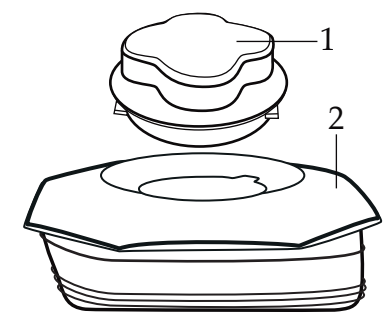
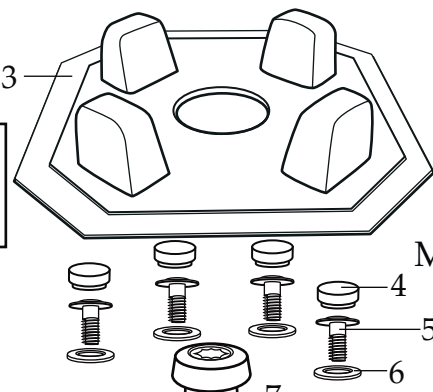

030855 Jar ONLY

030856 Jar with Blending Assembly

033038 Jar Complete with Blending Assembly and Lid (CAC106)

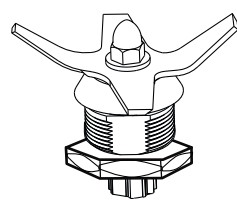

030857 Blending Assembly ONLY (with hex nut and washer)

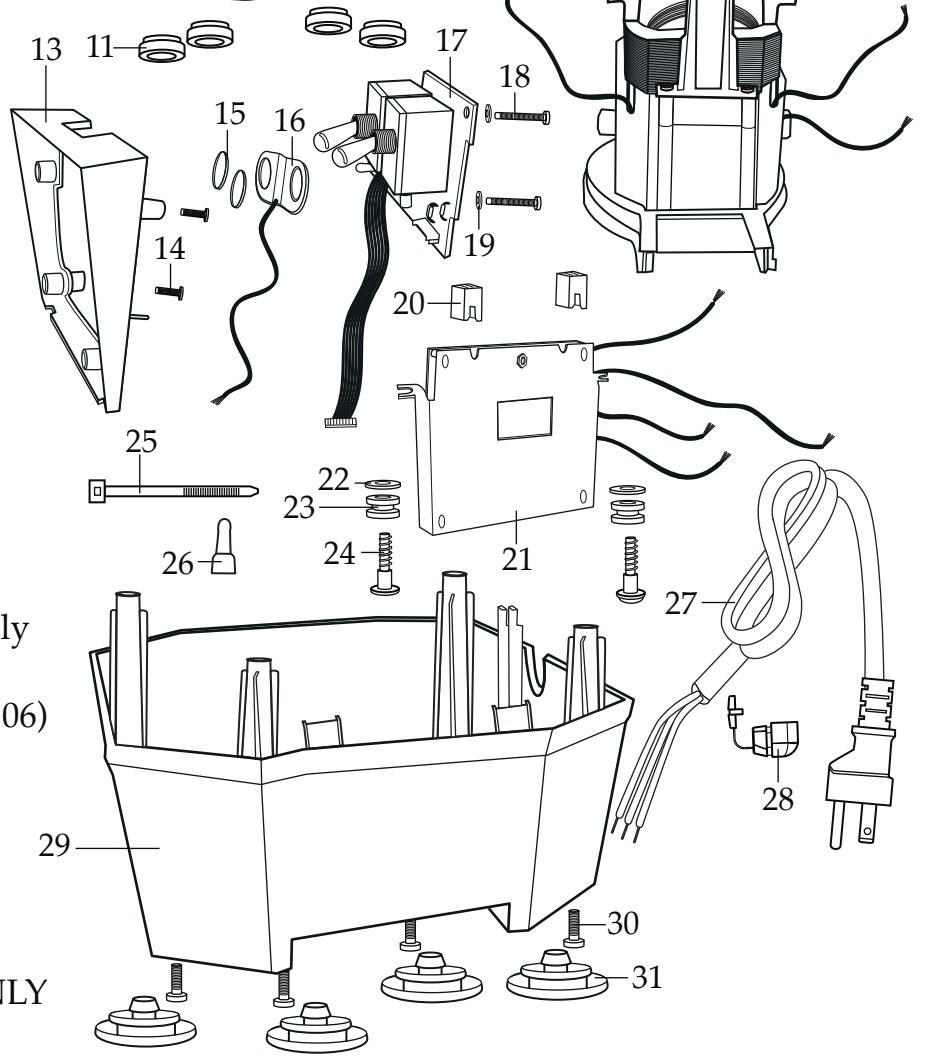

Illustration #	Part #	Description
1	030853	Center Lid
2	030854	Outer Lid
3	030858	Jar Pad
4	030859	Hole Plug (4 required)
5	030860	Screw (shoulder 4 required)
6	030861	Washer (4 required)
7	034349	Drive Coupling (<i>current production</i>)
	032496	Drive Coupling (<i>2nd generation effective October 20, 2011</i>)
	030862	Metal Drive Coupling (<i>older units</i>)
8	030864	Hex Nut (2 required)
9	030865	Lock Washer (2 required)
10	034350	Top Housing with Nameplate (<i>current production</i>)
	030863	Top Housing with Nameplate
11	030866	Motor Seal (4 required)
12	030874	Motor
13	030868W	Switch Bracket
14	030869	Screw (2 required)
15	030870	Washer (2 required)
16	030871	Grounding Bracket with Lead
17	030872	Switch Panel
18	030873	Screw (2 required)
19	031132	Washer (2 required)
20	031133	PCB Cushion (2 required)
21	030875	Main Board with Bracket
22	030876	Washer (2 required)
23	031130	Rubber Bushing (2 required)
24	030877	Screw (2 required)
25	013731	Cable Tie (4 required)
26	012409	Crimp Connector (small 3 required)
	019123	Crimp Connector (large 2 required)
27	030878	Cord
28	030879	Strain Relief
29	030880	Bottom Housing
30	030881	Screw (4 required)
31	030882	Foot (4 required)

